

# Screw stages with AC-Servo drive

## Complete drive system

### Main features:

- Drive force up to 800N
- Stroke from 35mm to 1 390mm
- Speed up to 940mm/s
- Optionally with bellows or steel cover
- Brushless AC servo motor with optional brake
- Programmable servo motor controller
- Analog and digital command interface (CANopen, Profibus, Sercos)
- Controller configured for spindle stage
- Stand alone solution for one axis or multi axes application



### Mechanical electrical parameters

Type	Upper part width	Upper part width with steel cover	Upper part length	Lower part length	Lower part interval	Total length	Height	Height with steel cover	Stage moving mass	Moving mass with steel cover	Brake force
	B		L2	L1		L3	H	(3)	Kg	(3)	Fb
	mm										N
LTB110.xxx.1205	110	122	110	150-950	60	335-1 135	40	47	0,8	1,5	1 800
.1210	110	122	110	150-950	60	335-1 135	40	47	0,8	1,5	900
LTB170.xxx.1605	170	202	170	280-1 600	60	522-1 842	60	69	2,3	3,3	1 800
.1610	170	202	170	280-1 600	60	522-1 842	60	69	2,3	3,3	900
LTB235.xxx.2505	235	275	235	280-1 600	60	536-1 856	85	97	5,9	8,5	3 000
.2510	235	275	235	280-1 600	60	536-1 856	85	97	5,9	8,5	1 500

### To be taken into account with the above table:

1. Mechanical stroke with steel cover or without cover = lower part length – upper part length – 10mm.
2. Mechanical stroke with bellows = (lower part length – upper part length)\* 83%mm.
3. Displayed value with steel cover with adapter plate.
4. Stage accuracy P2: height and side accuracy = (mechanical stroke / 71) +4µm.

5. Inductive limit switches integrated in stage. Electrical stroke = mechanical stroke – 2x10mm.

6. Total height including connectors 94mm (LTB110/170) and 107mm (LTB235). The LTB110 motor and flange are below the stage bottom part.

7. With brake L3 +33mm, with connectors L3 +75mm.

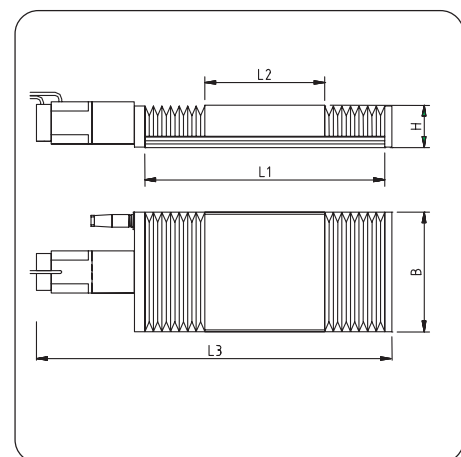

Drive force and speed

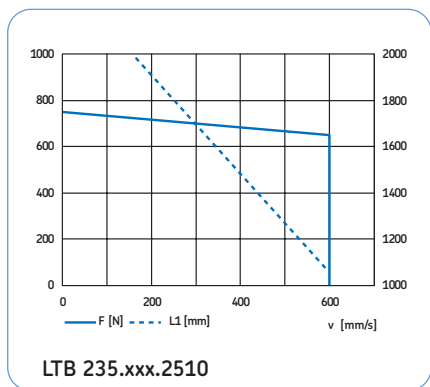
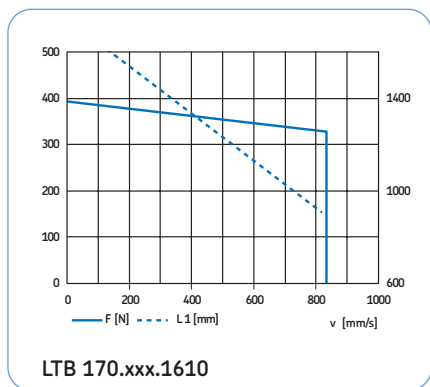
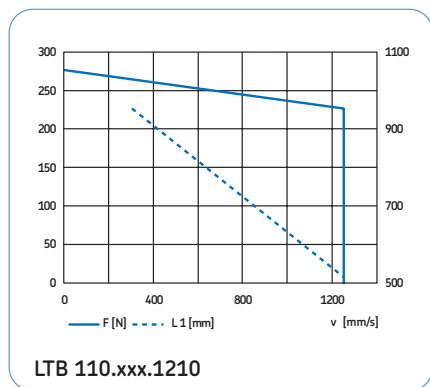
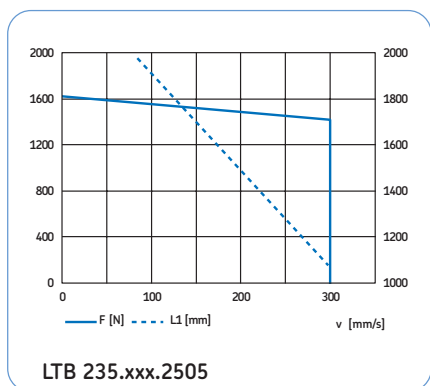
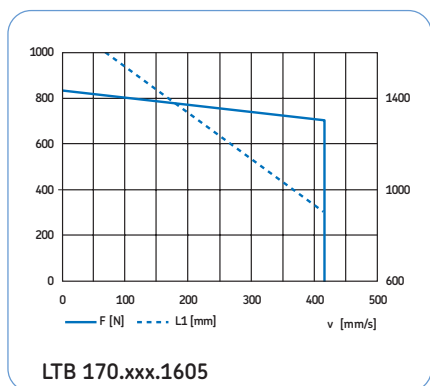
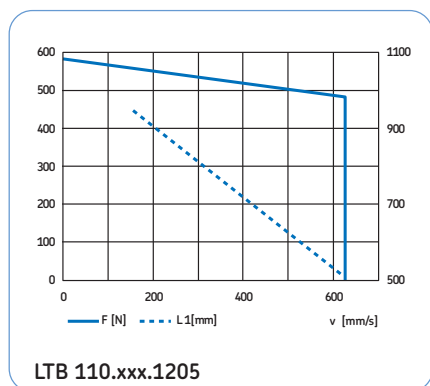

Note: Drive forces are based upon nominal motor torques (AKM22E for LTB110, AKM23D for LTB170, AKM32H for LTB235), as well as lead, idling torque, efficiency and guiding friction of the pre-loaded screw. The indicated forces are related to 100% duty cycle. Short-time overload permissible up to axial load rating (Coa) of the screw. The maximum stage speed is limited by the mechanical stroke (dotted line in the graphs). Other motor - stage combinations are available on request.

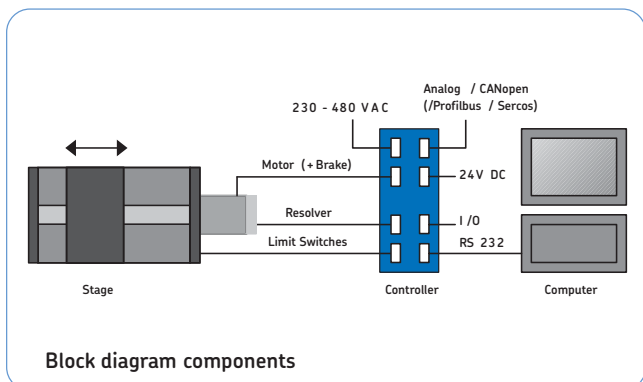

Controller data

- Controller configured for LTB stage
- 180 programmable motion sets
- Digital current, speed and position control
- Analogue ±10V command input
- RS232 and CANopen integrated. Optional Profibus or Sercos fieldbus
- Two digital inputs and two digital outputs, free useable
- Dimensions: 275x70x265mm (HxWxD)
- Standard cable length 5m
- Mains supply 115/230/400V AC. One phase main power supply may limit Fp. External 24V DC / 1A auxiliary voltage supply required
- Including user friendly controller software

