

Measuring Instruments for Large Dimensions



TESA – THE SPECIALISTS FOR LONG LENGTHS

For large dimensions from 250 mm up to several meters, TESA offers various types of measuring instruments that have long proven their value in practical use.

Whatever the sizes, from a simple distance between two surfaces parallel to one another measurement is always a challenge. Apart from the usual influences, which are proportional to the size whilst adding to your contributions in the uncertainty budget, those due to gravity play a key role in distortion.

Large sizes in mechanical engineering generally mean dimensions in excess of 500 mm. Various measurement procedures are brought into play, using such items as large internal and external micrometers with two-point contact, periphery tapes (for outside diameters), V-bases, rotating measuring disks (rolling-contact) optical systems (triangulation with theodolite), fixed gauges (inside caliper gauges), gauge blocks combinations or adjustable telescopic gauges.

There are other methods that often call for very simple techniques, such as fixed gauges (caliper gauges), combinations of gauge blocks, or even adjustable telescopic gauges.

Here's an example of a proportional relationship. With a bore of $\varnothing 1200$ H7, the tolerance area matches 0,1 mm. Reducing both values by a factor of 100 would give a manufacturing tolerance as low as $1 \mu\text{m}$. Of course, things are not as simple, but this example gives some ideas about the proportions.



TESA UNITEST Internal Micrometer

Measures internal dimensions in the micrometer's axis with 2-point contact with the workpiece to be checked – Optional accessories are available for inspecting centring shoulders and blind bores along with auxiliary means for external measuring.

Extensions with built-in gauge rods can be mounted on the measuring element, thus allowing any dimension within the application range to be measured, directly.



- DIN 863 T4 (Style B)
- Micrometer: 25 mm
- Dial gauge: ± 0,22 mm
- Micrometer and dial gauge: 0,01 mm
- Micrometer: 0,1 mm
- 8 µm
- Measuring bolts: Spherical and for measuring in the micrometer axis. All inserts are interchangeable
- Extension: 1 spherical and 1 flat measuring face
- 0,5 mm
- Tungsten carbide tipped
- 0,7 to 1N
- Extension: 26 mm dia. steel tube with snap-ring system. Also with built in gauge rods.
- Wooden case
- Setting standard with identification number
- Calibration certificate:
 - per setting standard
 - per measuring element
 - per extension
- Declaration of conformity



No	=				
		mm	mm	µm	
01110700	UNITEST (SET)	Internal dimensions 200 ÷ 1400			
CONSISTING OF:					
No	=				
		mm	mm	µm	
01110901	Measuring head	Internal dimensions 200 ÷ 225			
01141001	Setting gauge	Internal / external dimensions 200			
01110801	Extension		25		0,7
01110802	Extension		50		1
01110804	Extension		100		1,5
01110808	Extension		200		2,5
01110812	Extension		300		3,5
01110820	Extension		500		5,5
01160901	Screwdriver				
01162302	Case for Unitest				
OPTIONAL ACCESSORIES:					
01160701	Pair of tungsten carbide tipped measuring bolts for blind bores				
01162301	Auxiliary elements for external measurement		Measuring depth: ≤ 10		
01140801	Suspension device, complete		Measuring depth: ≤ 100		



TESA UNIMASTER Universal Measuring Instrument

TESA UNIMASTER Universal Measuring Instrument provides the features necessary for direct measurement of specially large internal and external dimensions. TESA UNIMASTER is similar to internal micrometers with two-point contact with the workpiece being measured. Measures any dimension within the extended application range directly by simply adding the needed extensions with built-in gauge blocks to the measuring element.

Accurate, robust and easy-to-handle – Can be used either vertically or horizontally with a constant measuring force – Incorporates a lever-type dial test indicator that clearly shows the culmination point – Ensures stable measuring owing to both a negligible deflection and thermal protection on each extension.

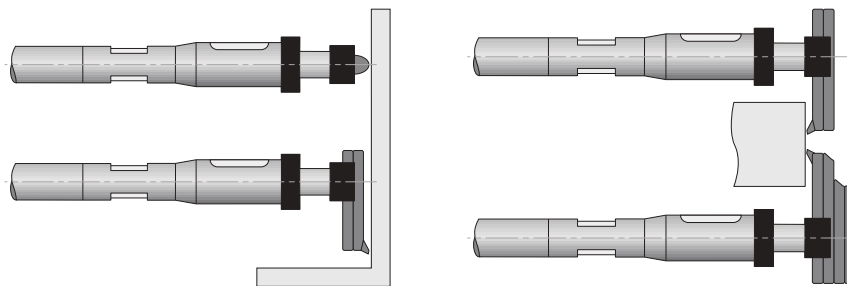

DIN 863 T4 (Style B)



Micrometer: 25 mm



Dial test indicator: $\pm 0,4$ mm



Micrometer and dial test indicator: 0,01 mm



5 μ m



One spherical and one flat measuring faces



1 mm



Tungsten carbide tipped



15 to 20 N measuring force reversible between internal and external directions



Measuring bolts supplied in pairs:

- No. 01110203 for internal measuring in the micrometer axis.
- No. 01110205 for internal/external measuring, meas. depth up to 60 mm from the lower edge of the micrometer.
- No. 01110208, extra-rigid for external measuring, meas. depth up to 75 mm from the lower edge of the micrometer.



Extension: 38 mm dia. diameter steel tube with snap ring system. Built-in gauge rod.



Mobile ball-bearing anvil under spring pressure.



Wooden case



Measuring element and setting standard with identification number



Calibration certificate:

- per setting standard
- per measuring element
- per extension



Declaration of conformity



No	=	mm	mm			
01110000	TESA UNIMASTER metric full	Int. dim. 250 ÷ 1475*	Ext. dim. 225 ÷ 1450*			
CONSISTING OF:						
No	=	mm	mm	mm	mm	µm
01110300	Measuring element UNIMASTER	Int. dim. 250 ÷ 275	Ext. dim. 225 ÷ 250			
01110203	Set measuring arms interior dimensions					
01110205	Set measuring arms for interior and exterior dimensions, length 75mm			75		
01110208	Set measuring arms for interior and exterior dimensions, length 100mm			100		
01110501	Setting gauge			Int. dim.: 250	Ext. dim. : 225	
01110101	Extension			25		0,7
01110102	Extension			50		1
01110103	Extension			75		1,2
01110104	Extension			100		1,5
01110105	Extension			125		1,5
01110106	Extension			150		2
01110112	Extension			300		3,5
01110118	Extension			450		4,5
01110124	Extension			600		6,5
01130001	Special screwdriver					
01110401	Set of suspension accessories (4 brackets together with 4 clamps)					
01112401	Wooden case for complet set					
OPTIONAL ACCESSORIES:						
01110140	Extension 1000 mm			1000		10
01162001	Anvils for internal/external dimensions and throats			Measuring depth: ≤ 20	Tungsten carbide inserts: Ø 4 x 7	
01160001	Roller (2 items are needed)					

*Using 3 extensions at the very most.

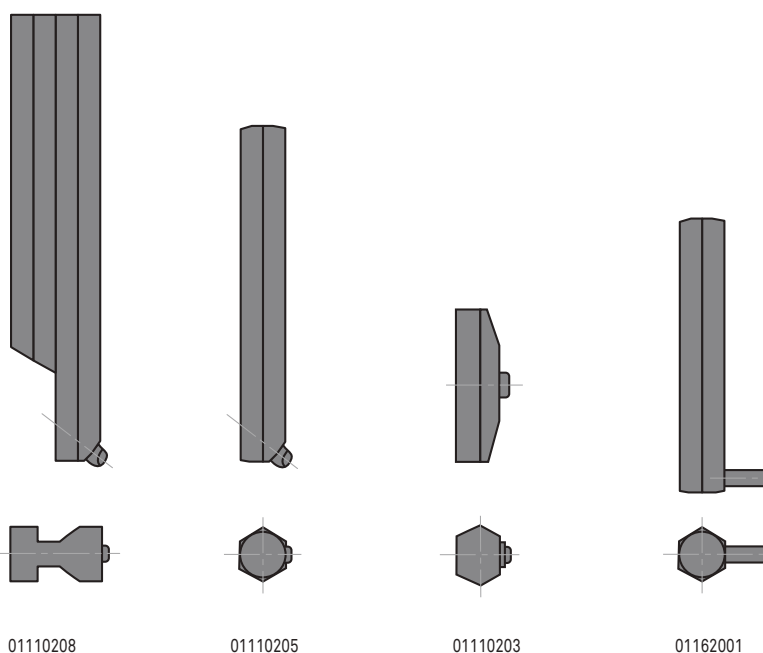

01110208

01110205

01110203

01162001



TESA INOTEST Comparative Measuring Instrument

Allows for comparative measurement of large internal or external dimensions. Consists of a measuring element with interchangeable inserts as well as a set of extensions. Since there is no material measure, the indication is set using a separate standard that can either be a gauge block, setting ring or horizontal measuring bench.

Measuring inserts for inspection in the tool axis, or offset inserts – Vertical or horizontal position of use – Integrated dial gauge to show the culmination point – Constant measuring force – Extensions with heat insulating grip.

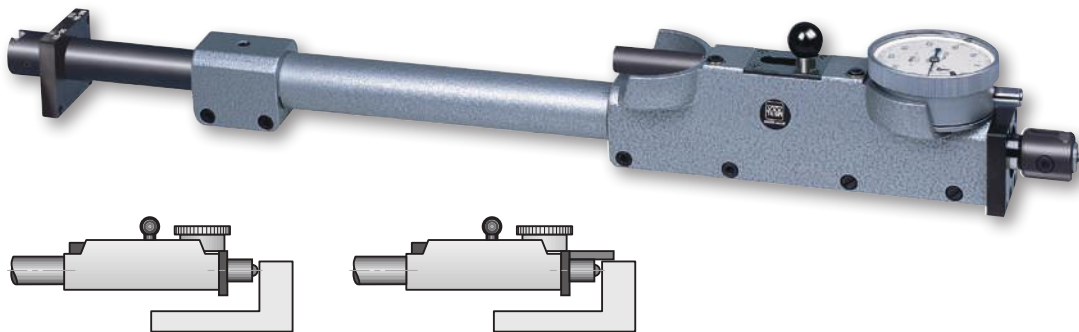
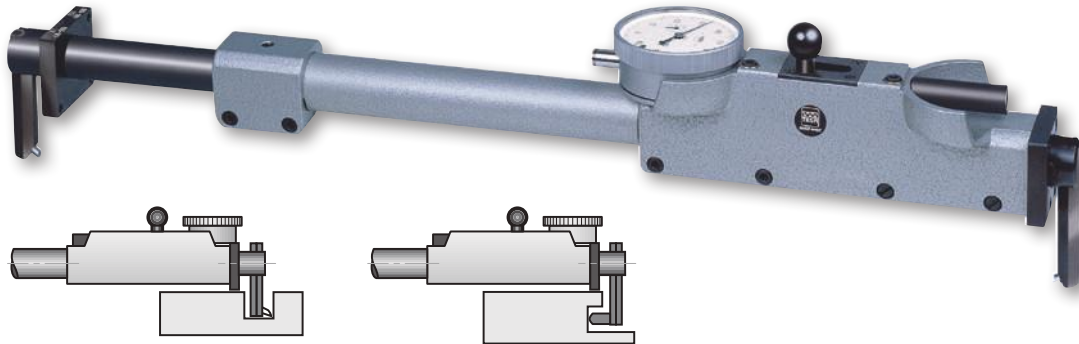
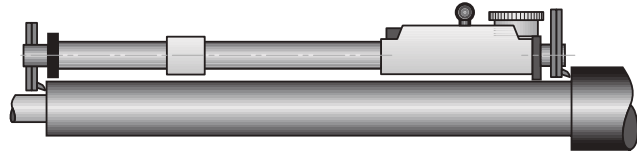

10 mm



0,01 mm



Measuring bold and extension: Tungsten carbide tipped



4 tp 7N. Reversible probing direction to allow both internal and external measuring.



Watertight dial gauge No. 01470104 and 01480100



Measuring bolts supplied in pairs:
 • No. 01131901 for internal measuring in the instrument axis.
 • No. 01131902 for internal/external measurement, measuring depth up to 30 mm from the lower edge of the tool



Extension: 25 mm dia. steel tube. 19 mm dia telescopic tube that can be clamped



Mobile ball-bearing anvil under spring pressure, 10 mm travel



For additional technical data: see chapter Indicators



Plastic case



Dial gauge with serial number



Declaration of conformity



Dial gauge with inspection report





No	=		
01111900	TESA INOTEST complete set	mm Int. dim. 275 ÷ 1025	mm Ext. dim. 250 ÷ 1010
CONSISTING OF:			
No	=		
01112301	Measuring element INOTEST		
01131901	Pair of inserts for internal measuring		
01131902	Pair of inserts for internal and external measuring, length 60 mm	60	
01132001	Set of 4 mounting rods	∅ 7 x 40	
00160101	3 insulating grips (reference code is for 1 item)		
01112001	Extension 250 ÷ 310 mm	Int. dim.: 275 ÷ 335	Ext. dim.: 250 ÷ 310
01112002	Extension 300 ÷ 410 mm	Int. dim.: 325 ÷ 435	Ext. dim.: 300 ÷ 410
01112003	Extension 400 ÷ 610 mm	Int. dim.: 425 ÷ 635	Ext. dim.: 3400 ÷ 610
01112004	Extension 600 ÷ 1010 mm	Int. dim.: 625 ÷ 1035	Ext. dim.: 600 ÷ 1010
01162303	Case INOTEST		
OPTIONAL ACCESSORIES:			
01141901	Extension 500 mm	500	
01141902	Extension 1000 mm	1000	
01162001	Carbide measuring inserts for throats	Measuring depth: ≤ 20	Tungsten carbide inserts: ∅ 4 x 7
01161900	Device for small dimensions, Inotest	Int. dim. 35 ÷ 280	Ext. dim. 15 ÷ 255



ETALON 532 Internal Micrometer

This micrometer is designed for measurements with 2-point contact.

Extensions with built-in gauge rods can be used to increase the measuring range – Stiff screw coupling.



Full set:			072109101	072109107	072109108	072109117	072109128
		mm	50 ÷ 170	50 ÷ 290	50 ÷ 530	50 ÷ 1010	50 ÷ 1510

COMPOSED BY:

		mm	mm	µm					
072103576	Micrometrical element	50 ÷ 65	3		•	•	•	•	•
072103585	Extention		15	1,5	•	•	•	•	•
072105462	Extention		30	1,5	•	•	•	•	•
072109030	Extention		60	2	•	•	•	•	•
072103586	Extention		120	2		•	•	•	•
072109055	Extention		240	3			•	•	•
072109066	Extention		480	3,5				•	•
072109089	Extention		500	3,5					•

- Factory standard
- 15 mm
- 0,01 mm
- Spheric (R = 15 mm)
- 29 mm
- 0,5 mm
- Tungsten carbide tipped
- Reference gauge rods
- Wooden case
- Declaration of conformity

ROCH Metric Periphery Tapes

Steel tapes with a dual graduation for measuring external circumferences and diameters of cylindrical parts on machines and other fittings – Suitable for malleable parts such as plastic tubing – Used for inspecting tanks or boilers – Also designed for checking steel or concrete pipes, rims, tires etc.

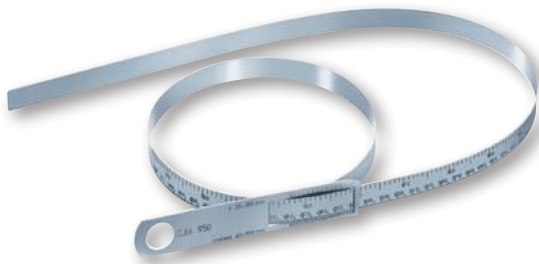

	Diameter, mm	Circumference, mm	mm
0951750222	20 ÷ 30	60 ÷ 950	0,15
0951750223	300 ÷ 700	940 ÷ 2200	0,20
0951750224	700 ÷ 1100	2190 ÷ 3460	0,20
0951750225	1100 ÷ 1500	3450 ÷ 4720	0,25

- Factory standard
- See table
- 0,1 mm
- 16 x 0,2 mm type section
- Steel band
- Shipping packaging
- Declaration of conformity