

Coordinate Measuring Machines



THE WAY TO ACCESS 3D MEASUREMENT

Conceived to provide operators with absolute ease of use, the TESA MICRO-HITE 3D steps in to fill the gap between the traditional gauge and the sophisticated CMM. This measuring machine with remarkable capabilities is best used in industrial applications where dimensional conformity of components either produced as single parts or in small to medium batches requires due approval.

Featuring a modern, yet proven design, the machine is built using high quality materials and components, thus ensuring its long-term reliability. The TESA-REFLEX software is intuitive and easy to learn taking only a few hours to master.



MH3D Dual



MH3D 454



MH3D 474





TWO TESA-REFLEX SOFTWARE VERSIONS

The TESA-REFLEX software is the reference for user-friendliness and reliability. Easy and quick to learn and to run, it lets users choose between a large number of options:

- Several modes: measuring, scanning, pass-through.
- Summon and save part programmes.
- Qualification of several probe positions.
- Different ways to save the measurement results: USB stick, RS232 digital output or printer.
- Automated operation

THREE MANUALLY OPERATED PROBE HEADS

All TESA CMM's can accept 3 different manual probe heads to offer the solution that meets each user's need. Each probe head is available from a full range of touch-trigger probes besides high precision SWISS MADE accessories fitting any type of hand-operated measuring machines.

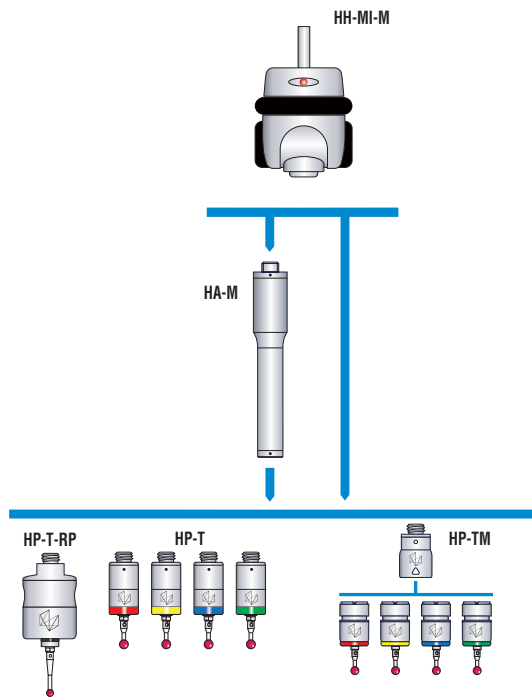



MICRO-HITE 3D Manual

Supplied with TESA-REFLEX software, the MICRO-HITE 3D can turn into a reliable and hard wearing all round shop floor machine easily integrated into the skill set of the operator. Multifunctional, yet easy to use, it is the metrological ace up the inspector's sleeve, replacing a wide range of conventional measuring tools.

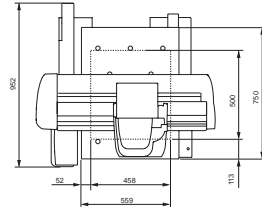
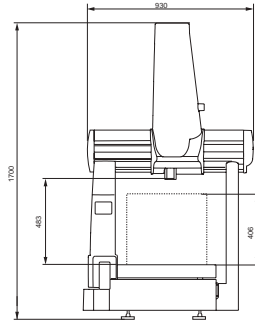

MH3D 454

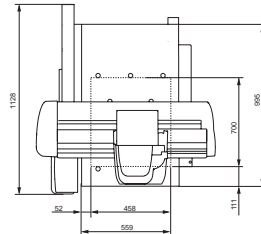
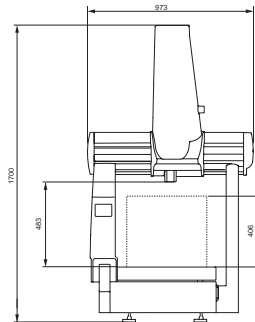

MH3D 474

- EN ISO 10360-2
- 0,001 mm or 0.00001 in
- Opto-electronic measuring systems based on incremental glass scales
- 760 mm/s
- Light alloy machine base, measuring table in granite
- 115 to 230 VAC ± 10 %, 50 to 60 Hz. Absorption 0,3 to 0,7 A
- Air pressure: 3,9 bars (60 to 120 psi). Air absorption: 60 NI/min.
- 13°C to 35°C
-
- Shipping box (W x D x H) : 1100 x 1150 x 2200 mm (for machine version 454) 1580 x 1400 x 2200 mm (for machine version 474)
- Inspection report
- 154 x 116 mm display field with illuminated background
- Measuring volume (X/Y/Z): 460 x 510 x 420 mm (machine version 454) 460 x 710 x 420 mm (machine version 474)
- Maximum dimensions for measured parts: (W x D x H) : 600 x 750 x 430 mm (for machine version 454) 600 x 990 x 430 mm (for machine version 474)
- CMM with moving bridge. Measuring systems along with air bearing guiding in the three coordinate axes.
- Net weight: Versions (454/474) = 210/315 kg (granite tables included). Tables alone : 99/120 kg. Gross weight : 300/445 kg. Maximum weight for measured parts: Version 454 : 227 kg Version 474 : 200 kg
- 20° ± 1°
- MPEE* = (3 + 4 L/1000) µm MPEP = 3 µm * L in mm
- 0,039 µm (system)
- Manual

No	=							
		Displacement	mm	Fine adjust device	Software	Measuring head	Maintenance agreement	Warranty
03939040	MH3D 454 (HH-T)	manual	454	No	TESA-REFLEX MH3D	HH-T	On request	1 year
03939041	MH3D 454 (HH-M)	manual	454	No	TESA-REFLEX MH3D	HH-MI	On request	1 year
03939042	MH3D-F 454 (HH-T)	manual	454	Yes	TESA-REFLEX MH3D	HH-T	On request	1 year
03939043	MH3D-F 454 (HH-MI)	manual	454	Yes	TESA-REFLEX MH3D	HH-MI	On request	1 year
03939240	MH3D 474 (HH-T)	manual	474	No	TESA-REFLEX MH3D	HH-T	On request	1 year
03939241	MH3D 474 (HH-M)	manual	474	No	TESA-REFLEX MH3D	HH-MI	On request	1 year
03939242	MH3D-F 474 (HH-T)	manual	474	Yes	TESA-REFLEX MH3D	HH-T	On request	1 year
03939243	MH3D-F 474 (HH-MI)	manual	474	Yes	TESA-REFLEX MH3D	HH-MI	On request	1 year

It is also possible to order a CMM including a HH-MI-M probe head.



- EN ISO 10360-2
- 0,001 mm or 0.00001 in
- Opto-electronic systems and incremental glass scales
- Manual mode: 760 mm/s Motorised mode: 200 mm/s
- Light alloy machine base; granite measuring table.
- 115 to 230 VAC ± 10 %, 50 to 60 Hz. Absorption: 0,3 to 0,7 A
- Air pressure: 3,9 bars (70 to 10 psi). Air absorption: 60NI/min.
- 13°C to 35°C
-
- shipping box (WxDxH): 1350 x 1350 x 2200 mm
- inspection report
- 154 X 116 mm display field with illuminated background
- Measuring volume (X/Y/Z): 440 x 490 x 390 mm
- Maximum size of the measured part (W/D/H): 600 x 750 x 430mm
- CMM with moving bridge. Measuring systems along with air bearing guiding in the three axes
- Net weight 225 kg (granite table included). Table alone: 99 kg. Gross weight: 350 kg. Maximum weight for the measured part: 227 kg.
- 20°C ± 1°C
- Manual mode: MPEE* = (3 + 4 L/1000) µm
MPEP = 3 µm
Motorised mode: MPEE* = (2,5 + 3,9 L/1000) µm
MPEP = 2 µm
* L in mm
- 0,039 µm (system)
- Manual probing movements. Manual or motorised execution of a part program.

MICRO-HITE 3D DUAL

The software is very well suited to the MICRO-HITE 3D DUAL, making it a versatile machine that can be used by everyone, whether in a laboratory or in a workshop. As it can be used in 2 modes this increases productivity and the machine can be used for a longer period of time in the manufacturing chain.

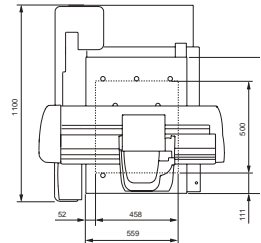
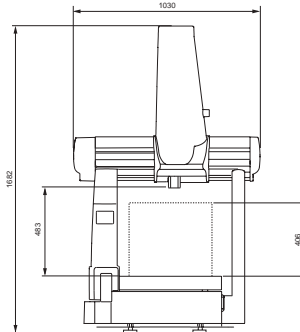

MH3D Dual 454

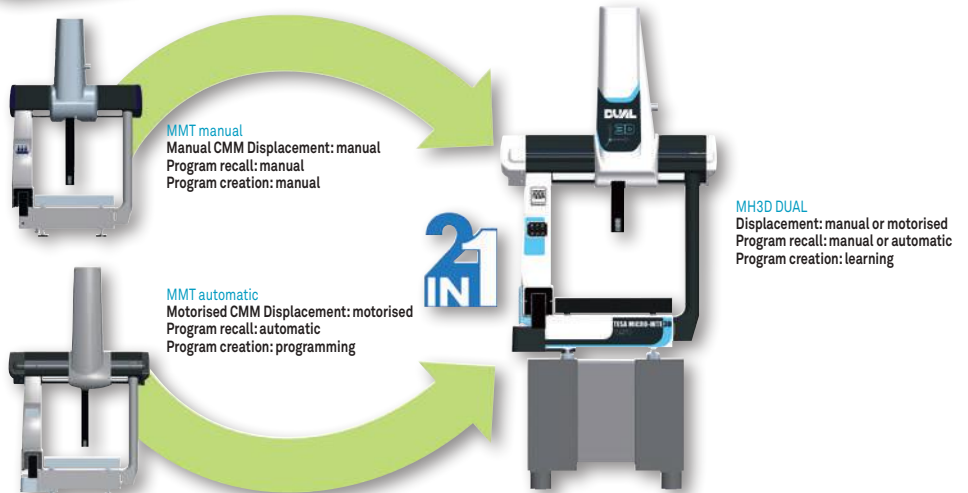

No	Icon	Displacement	mm	Software	Maintenance agreement	Warranty
03939267		manual, motorised, automatic	454	TESA-REFLEX Dual	HH-T	On request 1 year
03939268		manual, motorised, automatic	454	TESA-REFLEX Dual	HH-MI-M	On request 1 year
03939269		manual, motorised, automatic	454	TESA-REFLEX Dual	HH-MI	On request 1 year



HH-T Head

The HH-T is a compact manual probe head with adjustable triggering force.

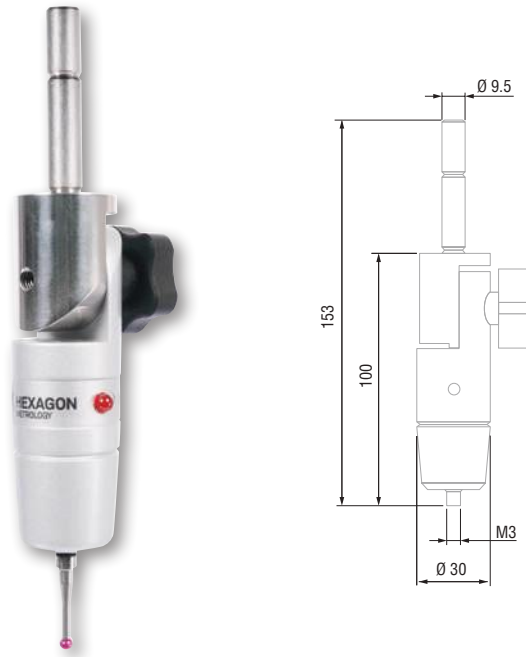

- EN ISO 10360-1
- Directions: $\pm X, \pm Y, +Z$
Free stylus travel: $X/Y \pm 20^\circ, Z + 6 \text{ mm}$
- -30°C to 60°C
- 10°C to 40°C
- Shipping box
- Inspection report with a declaration of conformity
- M3
- Manual

03939020	Head HH-T	Unidirectional, μm $\leq 0,75$	N $0,1 \div 0,3$	M3	Manual





EN ISO 10360-1

Directions: $\pm X$, $\pm Y$, $+Z$ Free stylus travel: $X/Y \pm 20^\circ$, $Z + 6 \text{ mm}$

-30°C to 60°C

10°C to 40°C

Shipping box

Inspection report with a declaration of conformity

Each axis can be locked by means of 2 push-buttons

M3

Indexation in increment of 15°

Indexation on 168 positions. Probe orientation: $A = 0^\circ$ to 90° $B = \pm 180^\circ$

Manual

HH-MI Head

The HH-MI is a high-precision indexable probe head integrating a built-in sensor with adjustable triggering force.

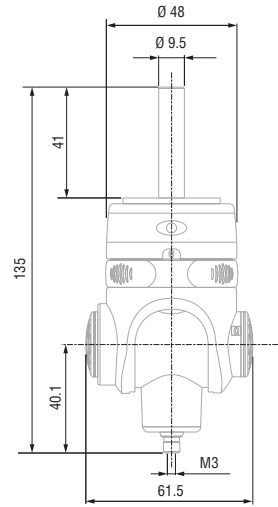

03939030	HH-MI Head	15°	168	Unidirectional, μm $\leq 0,75$	N 0,1 ÷ 0,3	M3	Manual



EN ISO 10360-1

Each axis can be locked by means of 2 push-buttons

-30°C to 60°C

10°C to 40°C

Shipping box

Inspection report with a declaration of conformity

M8

Indexation by increment of 15°

Indexation on 168 positions. Probe orientation: $A = 0^\circ$ to 90° $B = \pm 180^\circ$

Manual

HH-MI-M Head

The HH-MI-M is a high-precision, indexable manual probe head which can be fitted with any type of accessories featuring a M8 coupling thread.

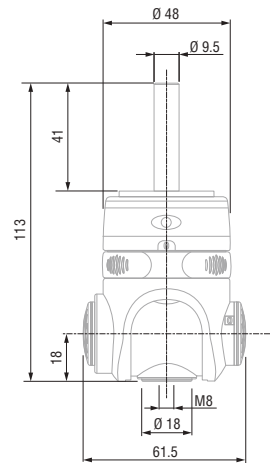

03939031	HH-MI-M Head	15°	168	Unidirectional, μm -	N -	M8	Manual



HP-T Probe

Consist of a small-size module with integrated probe and touch force triggered in 5 directions. M8 thread for coupling any existing probe head, whether manually operated or motor driven. Four models available with a trigger force varying from 0,05 up to 0,10 N.

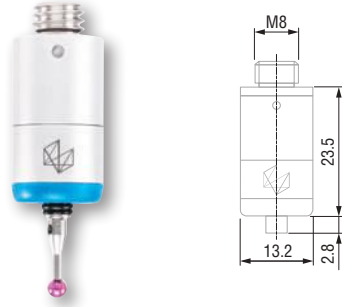

No	=				
		µm	N	Colour	
03939070	HP-T-LF	0,35	0,055 (L = 10 mm)	Red	LF = Low Force
03939071	HP-T-SF	0,35	0,08 (L = 10 mm)	Yellow	SF = Standard Force
03939072	HP-T-MF	0,5	0,10 (L = 25 mm)	Green	MF = Medium Force
03939073	HP-T-EF	0,65	0,10 (L = 50 mm)	Blue	EF = Extended Force

HP-T Probe Kit

Kit including several HP-T probes, allowing to face any application case with different triggering forces.

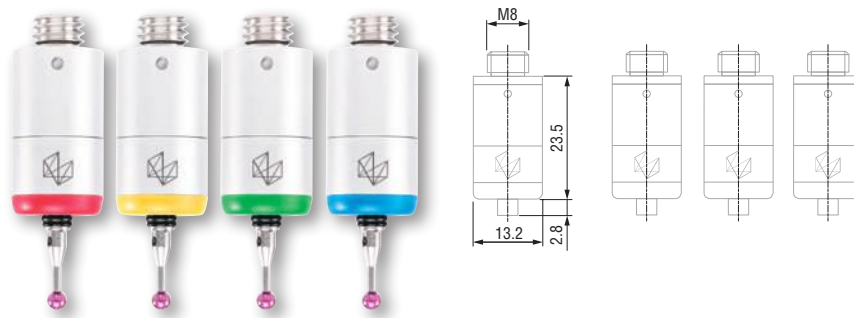

No	=		
03939074	HP-T probe kit	Standard probe	1 x LF + 1 x MF + 1 x SF + 1 x EF

- 600 µA (external supply)
- 5 directions ± X, ± Y, +Z Free stylus travel: X/Y ± 14°, Z + 4 mm
- 10°C to 70°C
- 10°C to 40°C
- IP50
- Shipping box
- Inspection report with a declaration of conformity
- M2
- 9,5 g



- 600 µA (external supply)
- 5 directions ± X, ± Y, +Z Stylus tilting through X/Y ±14°, Z + 4 mm
- 30°C to 60°C
- 10°C to 40°C
- IP30
- Shipping packaging
- Inspection report with a declaration of conformity
- M2
- Triggering force: 10N
- 13,6 g (probe body) 11 g (stylus)

HP-TM Probe

The HP-TM is a small system incorporating a magnetic and isostatic attachment between its body, fixed part of the attachment, and its module, interchangeable part, equipped with a measuring force triggered by contact in 5 directions.

Four models with a varying triggering force between 0,05 N and 0,10 N are available. The body is equipped with a M8 thread for mounting on most existing motorized or manual measuring heads.

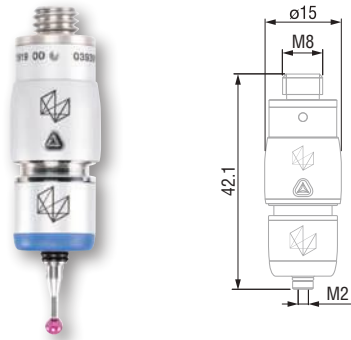

No	=				
		µm	N	Couleur	
03939170	HP-TM-LF	0,35	0,055 (L = 10 mm)	Red	LF = Low Force
03939171	HP-TM-SF	0,35	0,08 (L = 10 mm)	Yellow	SF = Standard Force
03939172	HP-TM-MF	0,5	0,10 (L = 25 mm)	Green	MF = Medium Force
03939173	HP-TM-EF	0,65	0,10 (L = 50 mm)	Blue	EF = Extended Force
03939174	HP-TM probe body	-	-	-	-

HP-TM Probe Kit

Probe kit including a HP-TM probe body and several modules, allowing fast, easy and safe changes in the system, without any negative impact on the measuring results.

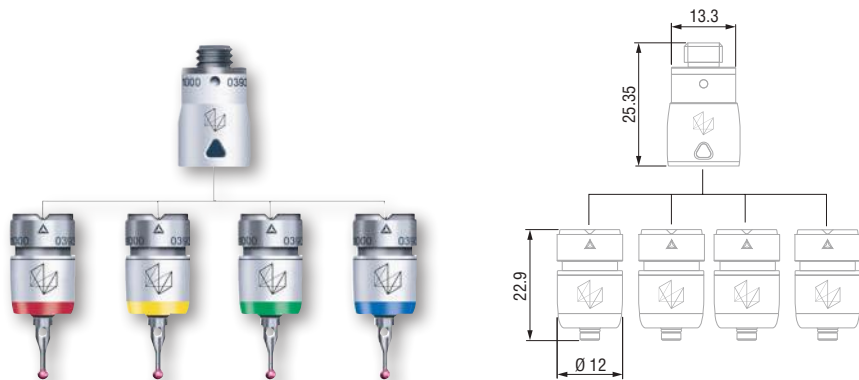

No	=		
03939175	Probe kit HP-TM N°1	Magnetic probe	1x LF + 1x MF + 1x SF + 1x EF + body
03939210	Probe kit HP-TM N°2	Magnetic probe	2x SF + body
03939211	Probe kit HP-TM N°3	Magnetic probe	1x SF + 1x MF + body
03939212	Probe kit HP-TM N°4	Magnetic probe	1x SF + 1x EF + body
03939213	Probe kit HP-TM N°5	Magnetic probe	2x MF
03939214	Probe kit HP-TM N°6	Magnetic probe	1x EF + 1x MF + body
03939215	Probe kit HP-TM N°7	Magnetic probe	2x EF + body
03939216	Probe kit HP-TM N°8	Magnetic probe	1x LF + body
03939217	Probe kit HP-TM N°9	Magnetic probe	1x SF
03939218	Probe kit HP-TM N°10	Magnetic probe	1x MF + body
03939219	Probe kit HP-TM N°11	Magnetic probe	1x EF + body



HP-T-RP Probe

HP-T-RP is a complete, robust and precise touch trigger probe, which can be used on any manual or motorised CMM as well as in any manufacturing environment, even the most hostile. Adjustable triggering force for optimum efficiency according to chosen configuration for the stylus. This force also allows for the use of styli whose weight and length are above normal.

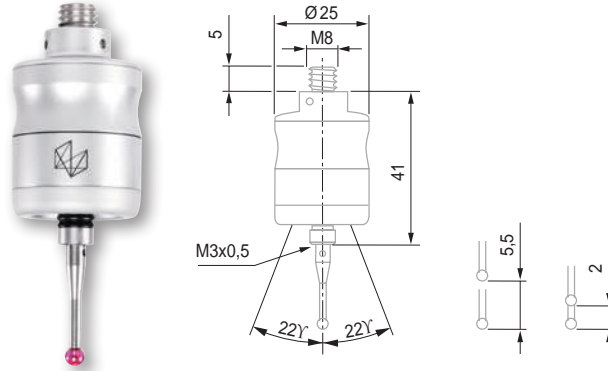

- 600 µA (external supply)
- 5 directions ± X, ± Y, +Z Free stylus travel: X/Y ±22°, Z + 5,5 mm
- 10°C to 70°C
- 10°C to 40°C
- IP50
- Shipping box
- Inspection report with a declaration of conformity
- M3
- 43 g

No	HP-T-RP	Unidirectional, µm	N	Robust probe	Length of stylus, mm	RP = Robust Probe
03939350	HP-T-RP	≤ 0,35	0,1 ÷ 0,3	Robust probe	≤ 100	RP = Robust Probe





Ruby Ball Stylus, M2 Thread

These styli are used for the majority of probing applications. Highly robust, thanks to their manufacture from industrial rubies, they are however very sensitive, thus avoiding any capture of unwanted points during the movements of a 3D machine.

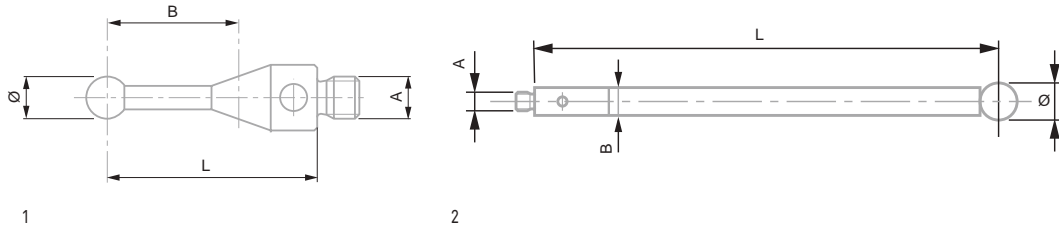

No	Rod	Drawing N°	A mm	Ø mm	L mm	B mm	g
03969201	Inox	1	M2	1	10	4,5	0,3
03969202	Inox	1	M2	2	10	6	0,3
03969203	Inox	1	M2	3	10	7,5	0,4
03969204	Inox	1	M2	4	10	10	0,5
03969205	Inox	1	M2	5	10	10	0,7
03969206	Inox	1	M2	6	10	10	1
03969208	Inox	1	M2	8	11	11	1,5
03969212	Inox	1	M2	2	20	14	0,5
03969213	Inox	1	M2	3	20	17	0,5
03969214	Inox	1	M2	4	20	20,2	0,8
03969220	Tungsten carbide	1	M2	0,5	10	3	0,3
03969221	Tungsten carbide	1	M2	1	20	7	0,6
03969222	Tungsten carbide	1	M2	2	20	15	0,45
03969223	Ceramic	1	M2	3	50	42,5	0,83
03969224	Ceramic	1	M2	4	50	42,5	0,91
03969225	Inox	1	M2	2,5	10	6	0,3
03969226	Tungsten carbide	1	M2	2,5	20	14	0,4
03969259	Tungsten carbide	1	M2	1	27	20,5	0,4
03969260	Carbon	2	M2	4	50	3	1
03969261	Tungsten carbide	1	M2	1,5	30	25	0,58
03969262	Tungsten carbide	1	M2	2	30	25	0,99
03969263	Tungsten carbide	1	M2	3	30	25	1,49
03969267	Tungsten carbide	1	M2	0,7	10	4	0,3
03969268	Tungsten carbide	1	M2	0,3	10	2	0,3
03969269	Tungsten carbide	1	M2	0,5	20	7	0,48
03969271	Tungsten carbide	1	M2	1	20	12,5	0,41
03969272	Tungsten carbide	1	M2	1,5	20	12,5	0,5
03969276	Carbon	2	M2	6	50	50	1,2
03969282	Tungsten carbide	1	M2	2	40	35	1,29
03969283	Tungsten carbide	1	M2	3	40	35	1,97
03969284	Tungsten carbide	1	M2	3	40	35	2,04
03969286	Carbon	2	M2	6	30	30	0,96
03969293	Carbide	1	M2	3	50	42,5	2,44
03969294	Carbide	1	M2	4	50	42,5	2,52
03969295	Tungsten carbide	1	M2	5	50	42,5	3,75



Ruby Ball Stylus, M3 Thread

These styli are used for the majority of probing applications. Highly robust, thanks to their manufacture from industrial rubies, they are however very sensitive, thus avoiding any capture of unwanted points during the movements of a 3D machine.

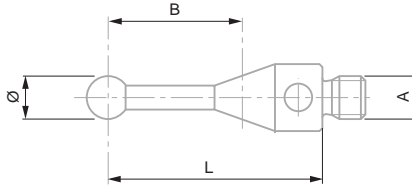

1

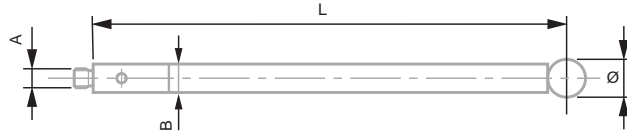

2

No							
	Rod	Drawing N°	A mm	Ø mm	L mm	B mm	g
03969301	Inox	1	M3	1	21	4	1,1
03969302	Inox	1	M3	2	21	8	1,1
03969303	Inox	1	M3	3	21	12	1,1
03969304	Inox	1	M3	4	21	17	1,4
03969305	Inox	1	M3	5	21	21	1,55
03969310	Tungsten carbide	1	M3	0,5	21	3	1,1
03969312	Tungsten carbide	1	M3	2	21	15	0,8
03969324	Inox	-	M3	3	10	-	-
03969326	Inox	-	M3	6	10	-	-
03969332	Tungsten carbide	1	M3	2,5	21	12,5	1,3
03969343	Tungsten carbide	1	M3	3	40	32,5	2,3
03969353	Tungsten carbide	1	M3	3	50	42,5	2,78









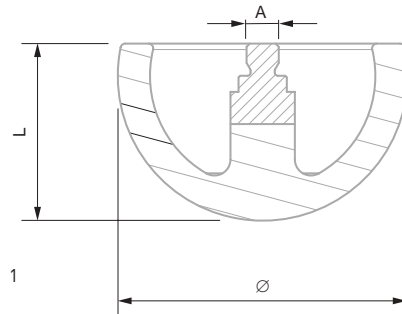

Hemispherical Styli, M2 Thread

Styli usually made of ceramic are generally used to measure deep bores or to avoid taking into account the unwanted irregularities when measuring.





No	=							
03969218	Hemispherical stylus, Ø 18 mm	Rod Ceramic	Drawing N° 1	A mm M2	Ø mm 18	L mm 11	B mm -	g 3,3

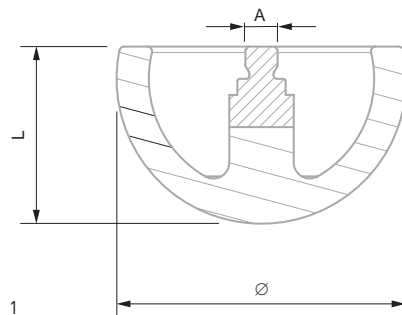

Hemispherical Styli, M3 Thread

Styli usually made of ceramic are generally used to measure deep bores or to avoid taking into account the unwanted irregularities when measuring.



No	=							
03969330	Hemispherical stylus, Ø 30 mm	Rod Ceramic	Drawing N° 1	A mm M3	Ø mm 30	L mm 17	B mm -	g 13



Star Styli, M2 Thread

These styli are supplied with several ruby ball tips fixed in different directions. This feature allows a much faster measurement when inspecting internal features without time being wasted by changing the position of a probe.

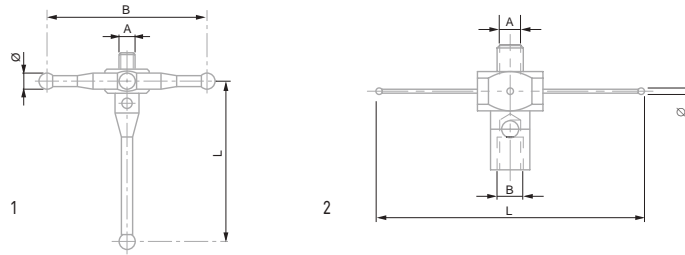

No	=		Rod		Drawing N°	A mm	Ø mm	L mm	B mm	g
03969055			Inox	1	M2	2	20	20	1,5	
03969056			Inox	1	M2	2	20	30	1,8	
03969081			Inox	1	M2	2	18	20	1,3	
03969082			Inox	1	M2	2	18	30	1,7	
03969210			Inox	2	M2	0,5	20	M2	0,7	

Star Styli, M3 Thread

These styli are supplied with several ruby ball tips fixed in different directions. This feature allows a much faster measurement when inspecting internal features without time being wasted by changing the position of a probe.

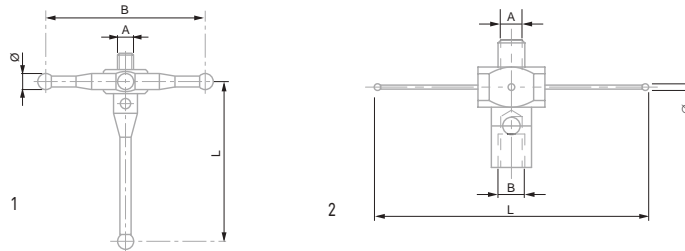

No	=		Rod		Drawing N°	A mm	Ø mm	L mm	B mm	g
03969057			Inox	1	M2	2	20	20	2,2	
03969058			Inox	1	M2	2	20	30	2,5	
03969083			Inox	1	M2	2	18	20	2,2	
03969084			Inox	1	M2	2	18	30	2,5	

Cylindrical Styli, M2 Thread

These styli are principally used for the measurement of threads.

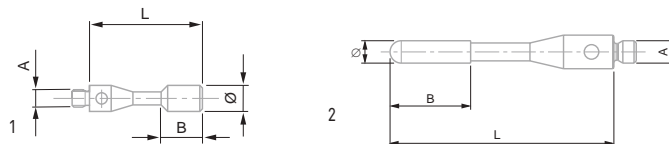

No			Rod		Drawing N°	A mm	Ø mm	L mm	B mm	g
03969251			Inox	1	M2	1,5	11	1,5	0,3	
03969252			Inox	1	M2	3	13	3,8	0,6	
03969253			Inox	1	M2	3	13	4	0,5	
03969292			Tungsten carbide	2	M2	2	20	7,2	0,5	





Parallel Styli, M2 Thread

These styli are principally used for the measurement of threads.

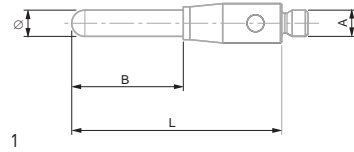

No	Rod	Drawing N°	A mm	Ø mm	L mm	B mm	g
03969277	Carbide	1	M2	0,5	15,3	7,8	0,3
03969278	Carbide	1	M2	1	35,5	29,8	0,7
03969279	Carbide	1	M2	2	16	8,5	0,8
03969280	Carbide	1	M2	2	40	32	2
03969281	Carbide	1	M2	3	22,5	-	2



Extension M2

The extension allows to enlarge the distance between the probe and the tip of the stylus in order to avoid collision in the depth measurement (e.g. bore).

The use of extensions can greatly reduce the accuracy of the measuring system.

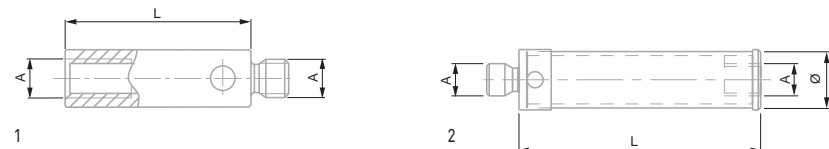

No	Extension	Rod	Drawing N°	A mm	Ø mm	L mm	B mm	g
03969230	Extension, L5 mm	Inox	1	M2	3	5	-	-
03969231	Extension, L10 mm	Inox	1	M2	-	10	-	0,5
03969232	Extension, L20 mm	Inox	1	M2	-	20	-	1
03969233	Extension, L30 mm	Inox	1	M2	-	30	-	1,6
03969234	Extension, L40 mm	Inox	1	M2	3	40	-	1,8
03969238	Extension, L50 mm	Carbon	1	M2	3	50	-	1
03969239	Extension, L70 mm	Carbon	1	M2	3	70	-	1,3
03969240	Extension, L90 mm	Carbon	1	M2	3	90	-	1,5
03969246	Extension, L40 mm	Ceramic	1	M2	3	40	-	1,22
03969247	Extension, L50 mm	Ceramic	1	M2	3	50	-	1,51
03969270	Extension, L40 mm	Carbon	1	M2	3	40	-	0,9



Extension M3

The extension allows to enlarge the distance between the probe and the tip of the stylus in order to avoid collision in the depth measurement (e.g. bore).

The use of extensions can greatly reduce the accuracy of the measuring system.

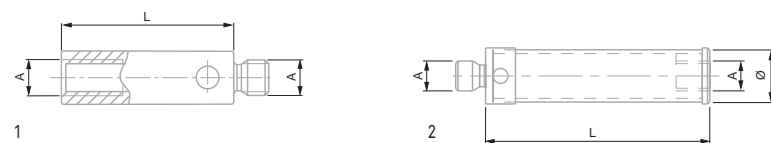

No	Extension	Rod	Drawing N°	A mm	Ø mm	L mm	B mm	g
03969044	Extension, L10 mm	Inox	1	M3	-	10	-	0,8
03969045	Extension, L20 mm	Inox	1	M3	-	20	-	1,8
03969320	Extension, L35 mm	Inox	1	M3	-	35	-	2,9



Cross-pieces, M2

Base on which one or several identical or different kind of styli can be mounted. It can be converted into a star stylus or any other desirable configuration.

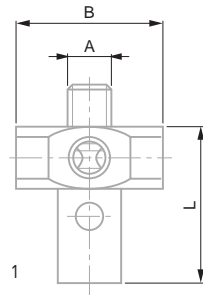

No	=	Rod	Drawing N°	A mm	Ø mm	L mm	B mm	g
03969054	5 way cross shaped stylus M2	Inox	1	M2	-	7,5	7	1,1

Cross-pieces, M3

Base on which one or several identical or different kind of styli can be mounted. It can be converted into a star stylus or any other desirable configuration.

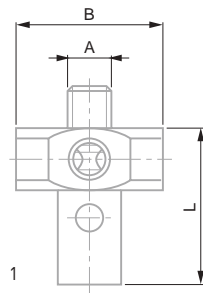

No	=	Rod	Drawing N°	A mm	Ø mm	L mm	B mm	g
03969046	5 way cross shaped stylus M3	Inox	1	M3	-	13	10	3,7

M2 Adaptors

In some cases, accessories that are directly compatible with a probe are not suitable for specific applications. Therefore, it is possible to use an adaptor in order to mount other styli with different threads on it.

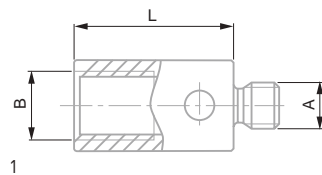

No	=	Rod	Drawing N°	A mm	Ø mm	L mm	B mm	g
03969061	Adapter M2-M3	Inox	1	M2	-	7	M3	0,5





M3 Adaptors

In some cases, accessories that are directly compatible with a probe are not suitable for specific applications. Therefore, it is possible to use an adaptor in order to mount other styli with different threads on it.

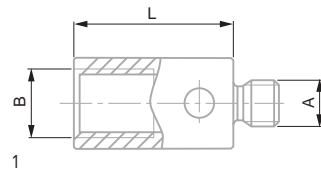

No	=							
		Rod	Drawing N°	A mm	Ø mm	L mm	B mm	g
03969062	ADAPTER M3-M2	Inox	1	M3	-	5	M2	0,5



Stylus Tightening Keys

Probes and styli are fragile and sensitive items. A special key is provided for fixing a stylus on the probe in order to prevent any damages caused by over-tightening.

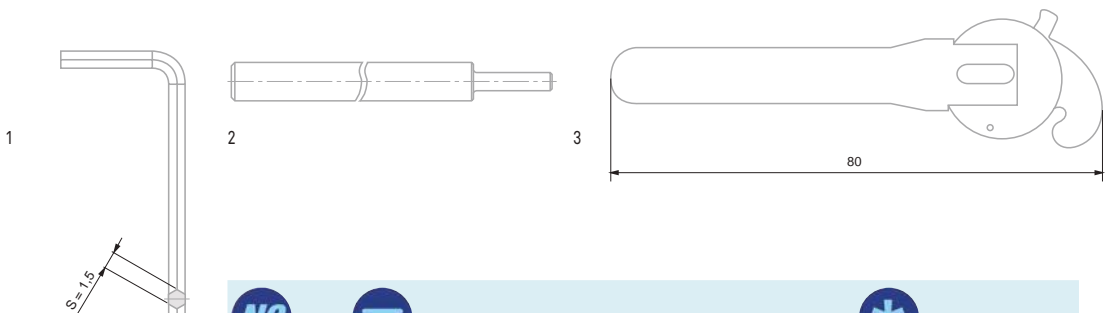

No	=	
		Drawing N°
042086	Hexagonal key 1,5 mm	1
047866	Stylus key M2 or M3	2
050697	Tightening key for carbon fibre styli	3



Stylus Kit

In order to perform several types of measurement, it is often necessary to keep several models of styli. This is why TESA has created standard kits, comprising styli for a variety of dimensions as well as extensions to suit.



No		Kit N° 1, M2 03969086	Kit N° 2, M2 03969087	Kit N° 3, M2 + rigid probe 03969089	Kit N° 1, M3 03969101	Kit N° 2, M3 + rigid probe 03969040
03969085	Case for accessories	1				
047866	Stylus key M2 or M3	2				
049652	Key	2				
050697	Tightening key for carbon fibre styli	2				
03969231	Extension, inox, M2, L = 10 mm	1	1	1		
03969232	Extension, inox, M2, L = 20 mm	1	1	1		
03969233	Extension, inox, M2, L = 30 mm		1			
03969270	Extension, carbone, M2, L = 40 mm	1				
03969044	Extension, inox, M3, L = 10 mm				1	1
03969045	Extension, inox, M3, L = 20 mm				1	1
03969054	5 way cross shaped stylus, inox, M2	1		1		
03969046	5 way cross shaped stylus, inox, M3				1	1
03969082	5 way cross shaped stylus, inox, M2	1				
03969201	Stylus, inox, ruby ball tip, M2, Ø 1 mm, L = 10 mm		1			
03969202	Stylus, inox, ruby ball tip, M2, Ø 2 mm, L = 10 mm	1	1			
03969203	Stylus, inox, ruby ball tip, M2, Ø 3 mm, L = 10 mm		1			
03969204	Stylus, inox, ruby ball tip, M2, Ø 4 mm, L = 10 mm	1	1			
03969212	Stylus, inox, ruby ball tip, M2, Ø 2 mm, L = 20 mm	2		1		
03969213	Stylus, inox, ruby ball tip, M2, Ø 3 mm, L = 20 mm	2		1		
03969221	Stylus, carbide, ruby ball tip, M2, Ø 1 mm, L = 20 mm	1				
03969260	Stylus, carbone ruby ball tip, M2, Ø 4 mm, L = 50 mm	1				
03969302	Stylus, inox, ruby ball tip, M3, Ø 2 mm, L = 21 mm				1	1
03969303	Stylus, inox, ruby ball tip, M3, Ø 3 mm, L = 21 mm				1	1
03969304	Stylus, inox, ruby ball tip, M3, Ø 4 mm, L = 21 mm				1	1
03969214	Stylus, inox, ruby ball tip, Ø 4 mm, L = 20 mm			1		
03969047	Rigid probe, Ø 6.35 mm			1		1



Basic Fixturing System

The basic clamping kit is perfect for fixing easily any prototype or single parts by using the inserts integrated in the granit measuring table of the TESA measuring machine.



03969010 Basic fixuring kit Is directly compatible with the inserts of the ganit table of the coordinate measuring machine.

Advanced Clamping System

Advanced clamping kit is an easy-to-use system built around the vertical supports to be screwed onto a base-plate. Other specific components are designed to be coupled to the extremity of the columns in order to optimise the flexibility of the device, obtain exactly the required heights and to lock at best the part to be measured.



03969504	Bronze SWIFTFIX Kit	= 03969507 + 03969510
03969505	Silver SWIFTFIX Kit	= 03969508 + 03969510
03969506	Gold SWIFTFIX Kit	= 03969509 + 03969510
03969507	Bronze FIXTURE Kit Case	Includes 46 fixuring elements, without baseplate
03969508	Silver FIXTURE Kit Case	Includes 66 fixuring elements, without baseplate
03969509	Gold FIXTURE Kit Case	Includes 93 fixuring elements, without baseplate
03969510	400 x 400 SWIFTFIX Baseplate	400 x 400 x 12 mm



Additional Software

As it is sometimes necessary to adapt your machine and the measurement process to specific needs, TESA offers additional software that makes the instrument more powerful.



No	=	✳
03969009	REFLEXSCAN 3D	For reverse engineering
04981004	STAT-EXPRESS Machine	To get real-time statistics
04981001	DATA-DIRECT	For the collection and processing of measurement data in real time



Camera Kit

This kit makes it easy to convert any 3D TESA machine into a profile projector! There is no need to own two separate machines to take readings of certain features that are impossible to measure in a tactile way, such as engravings or small parts.



No	=	✳
S39040072	Camera kit No. 1	With screen
S39040070	Camera kit No. 2	Without screen



 No	
03969065	Extension M8, L = 50 mm
03960175	Air saver
03960172	Separator
03969003	Protective cover
H005471	Joystick for MH3D Dual
03969103	Diaclean 1 l
03969047	Rigid probe
82-1631	TESA demo block
03969095	HEXAGON demo block
03969011	Qualification sphere without certificate
03969511	Qualification sphere with certificate
03969001	MH3D table with drawers
03960270	Table for MH3D
S39900072	USB printer

