



DESIGN



SWISS



CONNECTED



DIGITAL



TECHNOLOGY

The alliance between
SWISS MADE
and
INNOVATION



GENERAL INFORMATION	A	
CONNECTIVITY	A	
CALIPERS	B	
EXTERNAL MICROMETERS	C	
INTERNAL MEASUREMENT	D	
MEASURING INSTRUMENTS FOR LARGE DIMENSIONS	E	
DIAL GAUGES – ELECTRONIC AND ANALOGUE	F	
LEVER-TYPE DIAL TEST INDICATORS	G	
COMPARATIVE MEASUREMENT	H	
MEASURING SUPPORTS AND AUXILIARY FIXTURES	I	
STRAIGHTNESS, ANGLE AND INCLINATION MEASUREMENT	J	
LENGTH AND ANGLE STANDARDS	K	
CALIBRATION EQUIPMENT	L	
SURFACE ROUGHNESS TESTING	M	
HEIGHT GAUGES	N	
ELECTRONIC LENGTH MEASURING EQUIPMENT	O	
OPTICAL MEASUREMENT	P	
COORDINATE MEASURING MACHINES	Q	



THE DNA OF OUR INSTRUMENTS:

- 1 – The best materials
- 2 – Guaranteed precision across the measurement
- 3 – The cutting edge of technology and innovation
- 4 – Individual inspection and certification
- 5 – Long-term reliability



PRODUCTS

TESA tools have a strong reputation for quality, reliability and usability, and most of them proudly sport the 'Swiss Made' label.

Flagship products like the TESAMASTER micrometer, the CCMA dial caliper, the UNIMASTER large dimension gauge, the IMICRO internal micrometer and the 1D probes have been used in workshops for decades. TESA height gauges need no introduction – TESA's position as a world market leader speaks for itself.

At TESA, there is a relentless passion for innovation, and our new TESA LINK connector and wireless module are a major step forward into the digital world. Any TWIN-Cal IP40 or IP67 caliper can now communicate both ways with a computer.

Our wireless inductive probes are the result of over 3 years of R&D, and were launched in 2014. They offer unique characteristics, such as synchronised two-way communication, and guarantee reliable and fast measurements in both static and dynamic modes. A world first from TESA, they provide users with total freedom thanks to the wireless connection. SWISS MADE TESA machines are not to be outdone: they guarantee perfect measurement quality and stability over time, and have earned an excellent reputation in the world of tactile and optical metrology. By simplifying complicated operations, TESA has made quality control available to all by offering a full range of effective and flexible solutions. TESA machines are adapted to the requirements of our most demanding users, are easy to learn how to use, and provide a quick return on investment.



CUSTOMISED SOLUTIONS

For nearly 75 years, TESA has been working to solve its partners' metrological challenges. We are proud to continue offering you measurement solutions that build upon this success. We're here to help: our team of specialists have many years of experience and an unrivalled understanding of metrology. They are ready and waiting to help you develop applications that fully meet your requirements.





Dear Clients and Partners,

We are delighted to present you with our catalogue, which showcases both recent innovations and standard TESA products. It is these standard products that have forged the TESA Group's reputation over the years and made us the world leader in micro-metrology, but our new developments are not to be outdone, and are set to encourage the development of the digital factory of the future.

More than ever at TESA, our guiding principles are precision, reliability, innovation and the Swiss Made label, and we are convinced that your most difficult metrological challenges will meet their match in our standard and customised solutions.

Our expertise in dimensional measurement and commitment to training are the inspiration for the catalogue's more theoretical sections, which are full of advice and information on the art of measurement.

Enjoy!



*Stefan Ruh,
Managing Director of the TESA Group*



SERVICE

We offer a range of services, such as calibration, repair, maintenance, technical support, training and instrument customisation to meet your needs, and enable you to use your TESA instruments and machines in the best conditions possible.

For more information, please contact our customer service department, your nearest TESA branch, or fill in the customer service contact form on our website www.tesagroup.com



Customer Service TESA SA

Rue du Bugnon 38
1020 Renens, Switzerland
Tel: +41 (0)21 633 16 00
tesa-service@hexagonmetrology.com



www.tesagroup.com

REGISTER YOUR INSTRUMENT

You can now register your instrument on our website at www.tesagroup.com, and take advantage of a whole range of benefits, such as our warranty extensions on TESA height gauges.

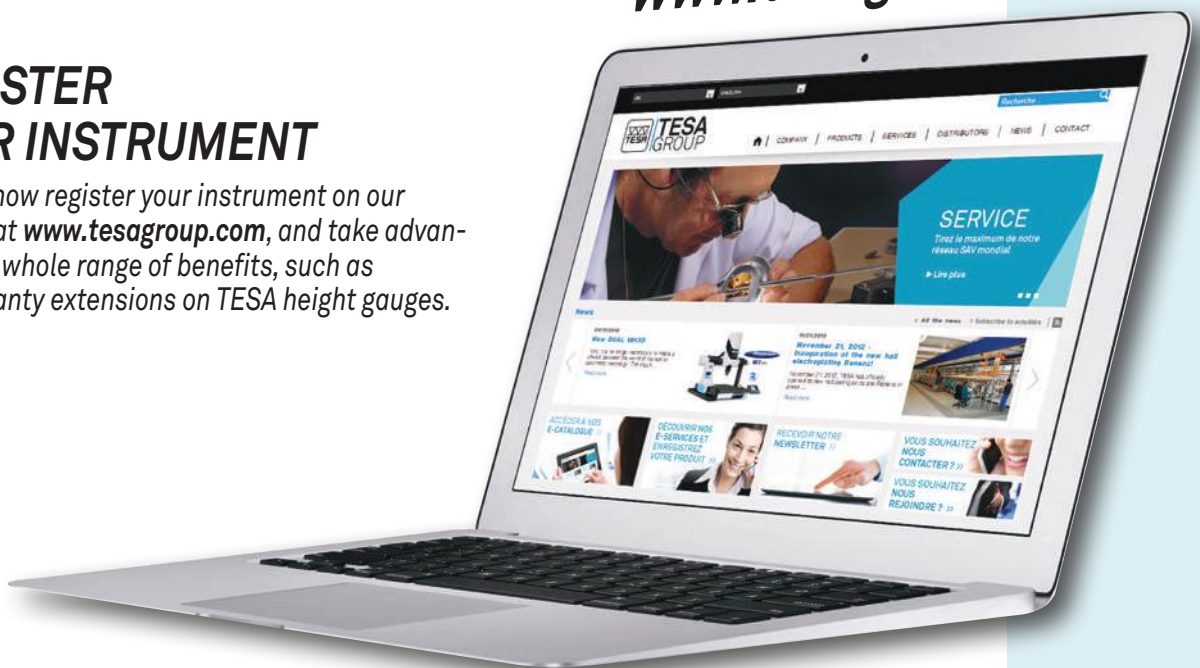



INTERNATIONAL PRESENCE

The TESA group operates on all continents via its global distribution network.

Our Head Office in Renens is located in the homeland of Swiss watchmaking and precision engineering, in close proximity to internationally-renowned engineering schools. It is home to a Research and Development department with nearly 50 team members, and a large production site.



ALPHABETICAL INDEX

All products are also listed by order numbers on the last pages.

A

Accessories for axial probes

– Extensions for Inserts with M2 Thread	0-60
– Hemispherical Measuring Inserts, M2 Thread	0-60
– Measuring Insert with Cylindrical Measuring Face, Lock Nut for Radial Alignment, M2 Thread	0-60
– Spherical Measuring Inserts, R = 5 mm, M2 Thread	0-60
– Extensions for Measuring Inserts, Ø 4 mm, 10 – 40 mm	0-61
– Insert with Cylindrical Measuring Face, Counter Nut for Radial Alignment	0-61
– Spherical Measuring Inserts, R 1 – 8 mm, L > 18mm	0-61
– Spherical Measuring Inserts, R = 5 mm, L = 6 mm	0-61
– Spherical Measuring Insert with 4 Interchangeable Pins, R = 1,5 mm, Length 16-46 mm	0-61
– Standard Spherical Measuring Inserts, R = 1,5 mm, L = 6 mm	0-61
– Inserts with a Flat Measuring Face Ø 1,5 mm, Interchangeable Pin, Steel or Carbide	0-62
– Inserts with a Flat Measuring Face, Ø 2,5 – 3,4 mm	0-62
– Inserts with Flat Measuring Face, Ø 2 mm, Steel	0-62
– Inserts with Flat Measuring Face, Ø 5 – 10 – 20 mm	0-62
– Insert with Off-centre (6,5 mm) Narrow Face, Lock Nut for Radial Alignment	0-62
– Insert with Offset (6,5 mm) Measuring Contact Point, Lock Nut for Radial Alignment	0-62
– Inserts with Blade-shaped Measuring Face, Lock Nut for Radial Alignment	0-63
– Insert with a Flat Measuring Face, Ø 2,5 mm, Adjustable Parallelism, Counter-nut for Radial Alignment	0-63
– Insert with Narrow Measuring Face, Adjustable Parallelism, Counter-nut for Radial Alignment	0-63
– Insert with Needle Contact Point	0-63
– Insert with Offset (12 mm) Contact Point, Lock Nut for Radial Alignment	0-63

– Measuring Inserts with Ball-bearing Rollers, Lock Nut for Radial Alignment	0-63
– Clamping Elements for Axial Probes	0-64
– Spare Bellows for Axial Probes	0-64
– Spring Sets for Axial Probes	0-64

Accessories for coordinate measuring machines

– HH-T Head	Q-6
– HH-MI Head	Q-7
– HH-MI-M Head	Q-7
– HP-T Probe	Q-8
– HP-T Probe Kit	Q-8
– HP-TM Probe	Q-9
– HP-TM Probe Kit	Q-9
– HP-T-RP Probe	Q-10
– Ruby Ball Stylus, M2 Thread	Q-11
– Ruby Ball Stylus, M3 Thread	Q-12
– Hemispherical Styli, M2 Thread	Q-13
– Hemispherical Styli, M3 Thread	Q-13
– Star Styli, M2 Thread	Q-14
– Star Styli, M3 Thread	Q-14
– Cylindrical Styli, M2 Thread	Q-14
– Parallel Styli, M2 Thread	Q-15
– Extension M2	Q-15
– Extension M3	Q-15
– Cross-pieces, M2	Q-16
– Cross-pieces, M3	Q-16
– M2 Adaptors	Q-16
– M3 Adaptors	Q-17
– Stylus Tightening Keys	Q-17
– Stylus Kit	Q-18
– Basic Fixturing System	Q-19
– Advanced Clamping System	Q-19
– Additional Software	Q-20
– Camera Kit	Q-20

Accessories for Dial Gauges

– Inserts for dial gauges, axial probes, etc.	
– Execution with M2,5 thread	F-25-28
– Inserts for dial gauges, axial probes, etc.	
– Execution with M2 thread	F-28
– Additional accessories for dial gauges	F-29



Accessories for lever dial test indicators

– Accessories for TESATAST	G-6
– Clamp	G-6
– Mounting Rods	G-6
– Fixing Shank	G-6
– Measuring Inserts	G-9
– Accessories for INTERAPID 312	G-9
– Clamping Attachment	G-9
– Holders	G-9
– Clamping Attachment	G-9
– Reducing Sleeve	G-9
– Measuring Inserts for COMPAC Models	G-13
– Accessories for COMPAC	G-13
– Swivel Clamps	G-13
– Mounting Rods with Dovetail Grip	G-13
– Mounting Rods	G-14
– Fixing Shank	G-14
– Clamp	G-14

Accessories for universal FMS probes

– Insert with $\varnothing = 2$ mm Diameter Contact Pin, Hemispherical Face with $\varnothing 4$ mm Diameter Mounting Shaft for FMS Probes	O-66
– Probe Inserts with a Flat Rectangular Face, $\varnothing 4$ mm Mounting Shaft for FMS Probes	O-66
– Probe with 2 Cylindrical Measuring Faces with $\varnothing 4$ mm Mounting Shaft, for FMS Probes	O-66
– Probe with Ball Tip $\varnothing 4$ mm for FMS Probes	O-66
– Barrel Shaped Inserts for Bores, $\varnothing 6$ mm Mounting Shaft, for FMS Probes	O-67
– Disc Inserts for Grooves, $\varnothing 6$ mm Mounting Shaft, for FMS Probe	O-67
– Inserts with Ball Tip, $\varnothing 6$ mm Mounting Shaft, for FMS Probes	O-67
– Special Inserts, $\varnothing 6$ mm Mounting Shaft, for FMS Probes	O-67
– Universal Probe Holder with $\varnothing 6$ mm Mounting Shaft, for FMS Probes	O-67
– Auxiliary Springs and Pneumatic Retraction Jack, for FMS Probe	O-68
– Fixed Holder, for FMS Probe	O-68
– Holder with Fine Adjustment for FMS Probe	O-68
– Inserts with Offset Measuring Faces, for FMS Probes	O-68
– Spring Set with Specific Measuring Force, for FMS Probe	O-68

Auxilliary Equipment

– INTERAPID Depth Foot with a Flat Face	I-12
– INTERAPID Depth Foot with Prismatic Measuring Face	I-12
– Brown & Sharpe CENTER FINDER Centering Tool	I-12
– Brown & Sharpe Positioning Block Set	I-13
– Brown & Sharpe V-Block Set with Clamping Bridge	I-13
– Brown & Sharpe Adjustable Parallels	I-14
– ROCH Flexible Rules	I-14
– ROCH Thickness Gauges	I-15
– ROCH Radius Gauges	I-15
– ROCH Screw Pitch Gauges	I-15
– ROCH Portable Magnifier	I-16

B-C

Calipers

– Models TESA CCMA-M	B-6
– Model TESA CCMA-M, 0,01 mm	B-6
– TESA CCMA-P Models	B-7
– ETALON 125 Model	B-7
– Depth Measuring Foot	B-8
– Magnetic Magnifying Glass	B-8
– Standard Models	B-9
– Models with Rounded Measuring Faces for Internal Dimensions (Without Fine Adjust Device)	B-13
– Models with Rounded Measuring Faces (With Fine Adjust Device)	B-13
– Models with Knife-edge Jaws for External Dimensions and Rounded Measuring Faces for Internal Dimensions (Without Fine Adjust Device)	B-14
– Models with Knife-edge Jaws for External Dimensions and Rounded Measuring Faces for Internal Dimensions (With Fine Adjust Device)	B-14
– Accessories for INTERAPID Light	B-21
– With Extra Long Jaws and Fine Adjust Device	B-22
– With Hook Jaws for External Dimensions	B-22
– With Knife-edge Jaws for Internal Dimensions	B-23
– With Vee Bridge	B-23
– For Turned Grooves	B-23



Comparative Measurement

- IRA 2 Comparative Gauge H-8
- Model for Sheets H-9
- Models with Open Inserts When Not in Use H-9
- Pair of Measuring Inserts in Special Version H-10
- INTERAPID SHE.30 for External Dimensions H-10
- INTERAPID SHE.35 for Internal Dimensions H-11

Connectivity

- DATA-DIRECT Software A-3
- STAT-EXPRESS Software A-4
- USB Accessories:
Adaptor Sub-D 9pm/USB,
Multiplexer USB, Foot Switch USB A-5
- TESA Portable SPC PRINTER A-6
- Wireless Connection
for TWIN-STATION Receiver A-7
- NEW: Transfer of Results
with TESA LINK CONNECTOR TLC A-8
- TWIN-STATION Receiver A-8
- Standard OPTO Connection A-9
- Standard Sub-D Connection A-9
- Connecting Cables from the Instrument
to a PC or Computer Controlled System A-10
- Hand / Foot Switches, Adapters, Battery
Chargers, Power Cables A-11
- Connecting Cables for RUGOSURF to PC
or Printer A-12

Coordinate Measuring Machines

- MICRO-HITE 3D Manual Q-4
- MICRO-HITE 3D DUAL Q-5

D

Depth Calipers

- TWIN-CAL IP67
– Models with Short Cut Measuring Face B-15
- TWIN-CAL IP67
– Models with One Fixed Measuring Jaw B-15
- TWIN-CAL IP67
– Models with Two Fixed Measuring Jaws B-15
- TWIN-CAL IP67
– Models with Rotary Stop Plate B-16
- TWIN-CAL IP67
– Small Sized Model with Steel
Measuring Tip B-16
- TESA Vernier Calipers
with a Flat Measuring Face B-17

- Calipers with Vernier Scale and Steel
Measuring Tip B-17
- Vernier Calipers
– Convertible Models with Short Cut Mea-
suring Face and Steel Tip B-17
- Vernier Calipers
with Rotary Stop Plate B-18
- Vernier Calipers
– Convertible Models with Fixed Stop Plate
and Short Cut Measuring Face B-18
- Removable Bridges B-18

Dial Gauges – Analogue

- Dial Ø 40 mm – Reading 0,01 mm F-11
- Dial Ø 57 / 58 mm – Reading 0,01 mm F-12
- Dial Ø 58 mm – Reading 0,01 mm
– Long travel F-13
- Dial Ø 82 mm – Reading 0,01 mm F-14
- Dial Ø 40 mm – Reading 0,002 mm F-15
- Dial Ø 58 mm – Reading 0,02 mm F-16
- Dial Ø 40 mm – Reading 0,001 mm F-17
- Dial Ø 58 mm – Reading 0,001 mm F-18
- Dial Ø 82 mm – Reading 0,001 mm F-19
- Dial Ø 40 / 58 – Reading 0,1 mm F-20
- Dial Ø 40 mm – Reading 0,01 mm F-21
- Dial Ø 58 mm – Reading 0,01 mm
– Long travel F-22
- Dial Ø 58 mm – Reading 0,01 mm
– Standard and long travel F-23

Dial gauges – Electronic and Analogue

- TESA DIGICO 205 / 305 F-3
- TESA DIGICO 400 / 500 F-4
- TESA DIGICO 600 F-5
- TESA DIGICO 705 F-6
- Accessories for TESA DIGICO 200 – 700 F-6
- TESA DIGICO 1 / 2 F-7
- TESA DIGICO 12 F-8
- TESA DIGICO 12 – HP F-9
- Accessories for TESA DIGICO 12 F-9
- ETALON HP High precision comparators
ETALON with short measuring travel F-10
- Dial Ø 40 mm – Reading 0,01 or 0,002 mm F-24

Digital Calipers

- TWIN-CAL IP67 B-3
- TWIN-CAL IP40 B-4
- TESA VALUELINE IP40 B-5
- TWIN-CAL IP67
– Models with Rounded Measuring Faces
for Internal Dimensions B-10



- TWIN-CAL IP67
– Models with Rounded Measuring Faces
for Internal Dimensions and
Knife-edge Jaws B-11
- TWIN-CAL IP67
– Models with Rounded Measuring Faces
for Internal Dimensions and Knife-edge
Jaws for External Dimensions B-12
- TWIN-CAL IP67 Horizontal Scale Unit B-19
- INTERAPID Light B-20

Digital Micrometers

- TESA MICROMASTER
Electronic Micrometers with Digital Display C-3
- MICROMASTER IP54 SET C-3
- MICROMASTER
Micrometers with Small Measuring Faces C-10
- TESAMASTER AD
Micrometers with Small Measuring Faces C-10
- MICROMASTER
Micrometers with Two Spherical
Measuring Faces C-12
- MICROMASTER
Micrometers with One Spherical
Measuring Face C-12
- MICROMASTER
Micrometers for Soft Materials C-14
- ISOMASTER AF
Micrometers for Soft Materials C-14
- MICROMASTER
Micrometers for Gear Pitch Measurement C-15
- ISOMASTER AE
Micrometers for Gear Tooth / Pitch
Measurement C-15
- Full Set of Measuring Inserts for
MICROMASTER with Interchangeable
Inserts C-16
- MICROMASTER
with 7 Pairs of Interchangeable
Measuring Inserts C-16
- MICROMASTER
Micrometers with Prismatic
Measuring Faces C-17
- Cylindrical Setting Standards
for Micrometers C-17
- MICROMASTER AC
Micrometers for Thread Measurement C-18
- ISOMASTER AC
Micrometers for Thread Measurement
Models C-18
- MICROMASTER
with Interchangeable Anvils C-22
- Dial Gauge Element for
MICROMASTER and AB Micrometers C-22

E-F

Electronic Length Measuring Equipment

- Probes with Axial Movement,
Ø 8 mm 0-6
- Probes with Axial Movement,
Ø 8 mm, with Activation of the Measuring
Bolt by Pneumatic Pressure 0-8
- USB, DC, Wireless Probes 0-10
- Probes with Axial Movement, Ø 8 mm 0-12
- Probe with Inclined Lever 0-12
- Unbranded Axial Probes with Measuring
Bolt Mounted on a Ball-bearing 0-12
- Universal FMS Probes 0-14
- GT31 Lever Probes ± 0,3 mm,
0,3 mm Measuring Travel, Inclined Lever 0-42
- Probes with parallel guidance,
± 2 mm or ± 2,9 mm,
5,8 mm measuring travel 0-43
- Probes with Parallel Guidance,
± 2 mm or ± 2,9 mm,
5,8 mm Measuring Travel 0-43
- Probes with Parallel Guidance,
± 2 mm or ± 2,9 mm, 5,8 mm Measuring
Travel – Protected Version 0-45
- TESATRONIC TT 10
Probe Display Unit 0-47
- TESATRONIC TT 20 and TT 60 Probe
Display Units 0-49
- TESATRONIC TT 80 and TT 90
Probe Display Units 0-51
- TESATRONIC TTA 20
Probe Display Unit 0-53
- Accessories for TESATRONIC TT Units 0-54
- TESA Probe Interface Boxes
– BPX Series 0-55
- TWIN-STATION Receiver
for TESA Wireless Probes 0-56
- Accessories for M4P-2 probe interface 0-57
- TESA Probe Interface Boxes
with Analogue Output – Series M4P-2 0-57
- Calibration Standards
– Dummy Probes 0-59

Electronic probe display units - up to 2 probes

- TESATRONIC TT 10 probe display unit 0-47
- TESATRONIC TT 20 and TT 60 probe
display units 0-49
- TESATRONIC TT 80 and TT 90 probe
display units 0-51
- TESATRONIC TTA 20 Probe Display Unit 0-53
- Accessories for TESATRONIC TT units 0-54



ETALON POLO
Horizontal Measuring Bench

- ETALON POLO with Floating Resting Table L-11
- Measuring Inserts for Internal Measurement used with the Floating Resting Table L-12
- Bench Stand with Swivelling Plate L-12
- Base for the Computing Counter L-12
- Floating Resting Table L-12
- Stands for Checking External Dimensions L-12
- Pair of Standard Measuring Inserts for External and Internal Dimensions from 10 mm L-12
- Stand with Ø 10 mm Fixing Bores L-13
- Centering Device L-13
- Fixing Shank L-13
- Holder for a Dial Test Indicator (Lever-type) L-13
- Spindle for Calibrating Dial Gauges, Dial Test Indicators and such like L-13

External Micrometers

- Interchangeable Thread Inserts for TESA Micrometers Series AC C-19
- Setting Standards for Screw Thread Micrometers
 - Metric, 60° or 55° flank angle C-19
- XB Wires for Screw Threads C-20
- Set of 16 Pairs of XB Wires for Thread Measurement C-20
- INTERAPID Setting Standards C-24
- ETALON Cylindrical Step Gauges C-24
- Guide Collars for Setting Standards C-24
- Micrometer Stands C-25
- Optical Flats with Two Parallel Faces C-25
- Set of Depth Rods for Micromaster C-26
- MICROMASTER Depth Micrometers C-26
- ISOMASTER AQ Depth Micrometers C-26
- MICROMASTER Micrometer Heads C-27
- TESAMASTER AR Micrometer Heads C-27
- ETALON 266 Micrometer Heads C-28
- ISOMASTER AR Micrometer Heads C-28

G

Gauge Block Comparators

- TESA UPD
 - For direct and comparative measurements L-4
- TESA UPC L-6
- Gauge Blocks for the Calibration of Comparators L-8
- TESA UP Software Programme for Value Processing L-8
- Additional Gauge Block Set for Calibration of the TESA UPD System L-9
- TESA UPT L-9

H

Height Gauges

- TESA-HITE Magna 400 / 700 N-4
- TESA-HITE 400 / 700 N-7
- TESA-HITE Plus M 400 / 700 N-10
- TESA MICRO-HITE 350 / 600 / 900 N-12
- Control Panel for TESA MICRO-HITE 350 / 600 / 900 N-15
- TESA MICRO-HITE Plus M 350 / 600 / 900 N-16
- Control Panels for TESA MICRO-HITE Plus M 350 / 600 / 900 N-19
- TESA IG-13 Probe Set for Perpendicularity Measurement N-20
- TESA-µHITE N-21
- Optional Accessories for TESA-µHite N-23
- Sets of Accessories for Height Gauges N-24
- Sets of Accessories for Height Gauges N-25
- Sets of Accessories for Height Gauges N-26
- Sets of Accessories for Height Gauges N-27
- Sets of Accessories for Height Gauges N-28
- Probe Holder No. 00760223 for Inserts with 8 mm Diameter N-29
- Optional Accessories for Use with Insert Holder No. 00760223 N-29
- Accessories for Measuring Perpendicularity by Means of a Dial Test Indicator N-30
- Accessories for ETALON Height and Scribing Gauges with Digital Display N-31
- ETALON Height and Scribing Gauges with Digital Display N-31



I-J-K

Internal Measurement

- | | | | |
|---|------|---|------|
| – TESA IMICRO
with Analogue Indication – Metric | D-3 | – TESA Gauge Block Set M47,
Metric | K-5 |
| – TESA IMICRO
with Analogue Indication
– Full Metric Sets | D-4 | – TESA Gauge Block Set M88,
Metric | K-5 |
| – TESA IMICRO CAPA μ SYSTEM
with Digital Display | D-5 | – TESA Gauge Block Set M122,
Metric | K-6 |
| – TESA IMICRO CAPA μ SYSTEM
with Digital Display – Full Sets | D-6 | – Special Versions | K-6 |
| – TESA IMICRO CAPA μ SYSTEM
with Digital Display
– Partial Sets | D-7 | – TESA Gauge Block Set M112,
Metric | K-6 |
| – Cases for Sets of
IMICRO Analogue | D-8 | – TESA Optical Flats | K-7 |
| – Cases for Single
IMICRO Digital Instruments | D-8 | – TESA Monochromatic Light Unit | K-7 |
| – Cases for Sets of
IMICRO Digital | D-8 | – Brown & Sharpe Angle Gauges | K-8 |
| – Cases for Single
IMICRO Analogue Instruments | D-8 | – Steel Balls – Brown & Sharpe Steel Balls | K-8 |
| – Accessories for Both TESA IMICRO and
TESA IMICRO CAPA μ SYSTEM
– Extensions for Deep Hole Measurement | D-8 | – TESA CARY Plug Gauges,
Diameters 0,050 to 0,300 mm – Type TDH | K-9 |
| – Accessories for Both TESA IMICRO and
TESA IMICRO CAPA μ SYSTEM
– Centring Devices for TESA IMICRO | D-8 | – TESA CARY Plug Gauges,
Diameters 0,050 to 0,300 mm
– Type TLH-5 – Type TLH-10 | K-9 |
| – ROCH ALESOMETER
with Analogue Indication, Metric | D-9 | – TESA CARY Plug Gauges,
Diameters 0.050 to 0,300 mm
– Type TTLH | K-10 |
| – ROCH ALESOMETER
with Analogue Indication
– Full Metric Sets | D-10 | – TESA CARY Steel Plug Gauges,
Diameters 0,3 to 10 mm – Type TXH | K-11 |
| – Extensions for Depth Increase for
ROCH ALESOMETERS – Analogue Models | D-10 | – TESA CARY Steel Plug Gauges,
Diameters 0,3 to 10 mm – Type TTXH | K-11 |
| – TESA ALESOMETER CAPA μ SYSTEM
with Digital Display | D-11 | – TESA CARY Tungsten Carbide
Plug Gauges, Diameters 0,3 to 6 mm
– Type TTCH | K-12 |
| – TESA ALESOMETER CAPA μ SYSTEM
with Digital Display – Partial Sets and
Components | D-12 | – TESA CARY Tungsten Carbide
Plug Gauges, Diameters 0,3 to 6 mm
– Type TCH | K-12 |
| – ETALON INTALOMETER 531 | D-13 | – TESA CARY Measuring Pins in Steel,
\emptyset 0,10 to 10 mm,
– Type PNH with Handle, for Thread
Measurement | K-13 |
| – ETALON INTALOMETER 531,
Metric Sets | D-14 | – Accessories for Plug Gauges and
Setting Rings | K-13 |
| – TESA TRI-O-BOR | D-15 | – TESA CARY Steel Ring Gauges,
Diameters 0,151 to 5 mm – Type BAH | K-14 |
| – Extension for Depth Increase
TESA TRI-O-BOR | D-16 | – TESA CARY Carbide Ring Gauges,
Diameters 0,060 to 5 mm – Type BCH | K-14 |
| – TESA TRI-O-BOR, Full Sets | D-16 | – TESA CARY Steel Ring Gauges,
Diameters 5 to 30 mm – Type BOMa | K-15 |
| – TESA Setting Rings and Setting Masters | D-17 | – TESA CARY Tungsten Carbide Ring Gauges,
Diameters 5 to 30 mm – Type BOMm | K-15 |
| | | – Accessories for Plug Gauges | K-16 |

L

Length and Angle Standards

- | | | | |
|------------------------------------|-----|--|-----|
| – TESA Gauge Block Set M32, Metric | K-5 | Lever-type Dial Test Indicators | |
| | | – TESA IP65
Electronic Dial Test Indicators | G-2 |
| | | – SWISSTAST Standard Models | G-4 |
| | | – TESATAST Perpendicular Models | G-4 |
| | | – TESATAST Standard Models | G-4 |



- Indicator Sets with Small Support G-5
- TESATAST Measuring Inserts G-5
- TESATAST Lateral Models G-5
- INTERRAPID 312 Perpendicular Models G-8
- INTERRAPID 312 Standard Models G-8
- Dial Test Indicator Sets, Complete with Accessories – INTERRAPID 312 Standard Models G-8
- COMPAC Series 210 – Standard Models, Metric G-11
- COMPAC Series 220 – Perpendicular Models, Metric G-11
- COMPAC 240 Reduced Range Models G-12
- COMPAC 230 Parallel Models G-12

M-N

Measuring Instruments for Large Dimensions

- TESA UNITEST Internal Micrometer E-3
- TESA UNIMASTER Universal Measuring Instrument E-4
- TESA INOTEST Comparative Measuring Instrument E-6
- ETALON 532 Internal Micrometer E-8
- ROCH Metric Periphery Tapes E-8

Measuring Stands

- INTERRAPID Magnetic Support with Articulated Arm (small) I-3
- INTERRAPID Magnetic Support with Articulated Arm I-3
- INTERRAPID Magnetic Support with High Precision Articulated Arm I-4
- INTERRAPID Magnetic Support with Flexible Arm I-4
- INTERRAPID Inclination Magnetic Support I-5
- INTERRAPID Support with Suction Base and Articulated Arm I-6
- INTERRAPID Small Measuring Support and Table Ø 49 mm I-7
- INTERRAPID Measuring Support with Inclination Frontal Arm I-7

- INTERRAPID UA 1 Table Measuring Support with Ground Table Surface I-8
- INTERRAPID UD12 Support I-8
- INTERRAPID Table Measuring Stands with Granite Grade 00 I-9
- UJ 15 Model I-10
- UJ 15G Model I-10
- Accessories for Small Magnetic Stands I-10
- INTERRAPID UA 30 Measuring Stand (Without Measuring Arm) I-11
- Accessories for UA 30 I-11

Micrometers with analogue indication

- TESAMASTER High Precision Micrometers with Digital Counter Reading to 0,1 mm C-4
- ETALON MICRORAPID 226 with 1 mm Revolution C-5
- ETALON 260 Standard Models with Analogue Indication C-5
- TESA ISOMASTER Standard Models with Analogue Indication C-6
- Set of 4 TESA ISOMASTER Micrometers C-6
- ETALON Basic to 0,01 mm C-7
- Set of 4 ETALON Basic Micrometers 0,01 mm Reading C-7
- Protective Cover for Micro-Etalon 225 C-8
- MICRO-ETALON 225 – Precision Micrometers with a Dial Indicator C-8
- ETALON MICROSPER 280 C-9
- MICRORAPID Micrometers with Small Measuring Faces C-11
- ISOMASTER AD Micrometers with Small Measuring Faces C-11
- ETALON Micrometers with One Spherical Measuring Face C-13
- Spherical Element for External Micrometers C-13
- ETALON Basic for Tube Wall Thickness Measurement C-21
- ISOMASTER AB with Interchangeable Anvils C-23
- Interchangeable Anvils for ISOMASTER ABY Series C-23

O

Optical Measurement

- PLASTIFORM Set P-27
- Accessories for PLASTIFORM P-28

P-Q-R

Probe Accessories

- Adaptor Cable:
DIN 5p Connector to USB Type A Connector 0-58
- Fixing Bracket
for TESA GT 31 Lever Probe 0-65
- Manual Measuring Bolt Retraction
for Axial Probes 0-65
- Probe Inserts
for GT 31 Lever Probes 0-65
- Connectors for Electro-pneumatic Pump
for Measuring Bolt Retraction 0-69
- Electro-pneumatic Pump
for Measuring Bolt Retraction 0-69
- Extension Cable
for Probes, Lengths = 1 – 20m 0-70

Probes with axial movement, Ø 8 mm

- Standard Probes,
± 1 mm, 4,3 mm Travel (GT21) 0-16
- Standard Probes,
± 1 mm, 4,3 mm Travel (GT22) 0-17
- Standard Probes ± 2 mm,
4,3 mm Bolt Travel, Linear Travel 0-18
- Standard Probes,
± 2 mm, 10,3 mm Travel,
with Long Retraction Travel 0-19
- Standard Probes ± 5 mm,
10,3 mm Bolt Travel, Extended Range 0-20
- GT 21 HP High Precision Probes,
± 0,2 mm, 4,3 mm Rravel 0-21
- GT 22 HP High Precision Probe,
± 0,2 mm, 4,3 mm Travel 0-22
- Pneumatic Probes ± 1,5 mm,
3,2 mm Bolt Travel, Linear 0-23
- Pneumatic Probes ± 2 mm,
10,3 mm Bolt Travel,
with Long Retraction Travel 0-24
- Pneumatic Probes ± 5 mm,
10,3 mm Bolt Travel, Long Travel 0-25
- GT 41 / GT 42 Miniature Probes,
± 0,3 mm, 0,7 mm Bolt Travel 0-37
- GT 43 / GT 44 Miniature Probes,
± 1,0 mm , 2,1 mm Bolt Travel 0-38
- Probes, Unbranded Execution, Series 410 ±
1 mm, 2,5 mm Range, Short Body 0-39
- Probes, Unbranded Execution,
Series 160 ± 1 mm, 3,3 mm Bolt Travel,
Short Body, Ø 6 mm 0-40
- Probes, Unbranded Execution, Series 430
and 451, ± 0,5 mm, 1,25 and 2,10 mm
Measuring Bolt Travel, Miniature 0-41

Profile Measurement Machines

- TESA-SCAN 52 REFLEX-Click P-3
- TESA-SCAN 25 P-4
- TESA-SCAN 50 P-5
- TESA-SCAN 50 CE+ P-6
- TESA-SCAN 50+ P-7
- TESA-SCAN 80/ 80+ P-8
- Fixturing Systems P-9
- TESA-REFLEX Scan Software P-13
- Pro-Measure Software P-14

Profile projectors

- TESA-SCOPE II 300V and 300V Plus P-20
- Telecentric Lenses for
TESA-SCOPE 300V and 300V Plus P-22
- Accessories for TESA-SCOPE
Vertical Model P-22
- TESA-SCOPE II 355H P-23
- Telecentric Lenses for
TESA-SCOPE 355H and H Plus P-25
- Accessories for TESA-SCOPE
Horizontal Model P-25
- TS100 Digital Readout P-26
- TS300 or TS300E Control Panel P-26

S

Straightness, Angle and Inclination Measurement

- TESA CLINOBEVEL 1 USB
Electronic Inclionometer J-3
- TESA CLINOBEVEL 2
Electronic Inclionometer J-4
- TESA MICROBEVEL 1
Inclinometer J-5
- TESA NIVELTRONIC
Electronic Levels with Analogue Display
and Integrated Galvanometer J-6
- TESA Spirit Levels – for Assembly J-7
- TESA Precision Spirit Levels J-8
- TESA Precision Spirit Levels with Frame J-8
- TESA Precision Spirit Levels Magnetic,
Square Models with Magnetic Inserts J-9
- TESA Precision Level with Micrometer
Element J-9
- TESA Spirit Inclinometer
with Protractor and Micrometer Element J-10
- Accessories for Clinometers and Levels J-11
- ROCH Bevelled Straight Edges J-12



- ROCH Flat and Try Squares in Steel
- Accuracy Class 1 J-12
- Brown & Sharpe Try Square Set J-13
- ROCH Bevelled Edge Squares
- Accuracy Class 00 J-13
- Angle Protractor with Digital Display J-14
- EAC Angle Protractor with Dial J-15
- ETALON Angle Protractor
with Vernier Scale J-15
- Brown & Sharpe Angle Protractor
- Multiple Combinations J-16
- Brown & Sharpe Sine Bar J-16

Surface roughness testing

- TESA RUGOSURF 20 M-4
- TESA RUGOSURF 10G M-7
- TESA RUGOSURF 90G M-10
- TESA PROFILE SET 2 mm M-13
- RUGOSOFT Software M-14
- MEASUREMENT STUDIO Software M-15
- PROFILE STUDIO Software M-16
- Standard Probes M-17
- Optional Probes for RUGOSURF surface
roughness gauges M-18
- Optional Probes for RUGOSURF 90 M-19
- PR Dot Matrix Printer M-20
- Accessories for PR Dot Matrix Printer M-21
- Other Accessories for RUGOSURF M-22
- Chargers and Rechargeable Batteries M-22
- Granite Bases with Measuring Support
Column M-23
- Ra Roughness Standards M-24
- Setting Standard for PROFILE SET M-24
- RUGOTEST
Roughness Comparison Specimens M-25

T

TESA VERIBOR Bore Gauges

- TESA VERIBOR Light H-5
- TESA VERIBOR H-6
- Set of Extensions H-7
- Depth Extensions H-7
- Dial Gauge Protection Guard H-7
- Accessories for IRA-2 Comparative Gauge H-8

TESA-VISIO Accessories

- Additional Lenses for 6,5 Zoom P-17
- Additional Lenses for 12x Zoom P-17

- Diascopic Parallel Light P-18
- Fixing Kit for TESA VISIO P-18
- Foot Switch for Data Capture P-18

TESA YA Bore Gauges

- Special Executions H-4
- Optional Accessories for TESA YA Bore
Gauges H-4

Tool Set

- TESA SWISS TOOL SET C-29
- TESA DUO-SET 1 C-30
- TESA DUO-SET 2 C-30
- TESA DUO-SET 8 C-31
- TESA DUO-SET 9 C-31
- TESA DUO-SET 14 C-32
- TESA DUO-SET 13 C-32
- TESA DUO-SET 15 C-33
- TESA DUO-SET 16 C-33

U

USB, DC, Wireless Probes

- Wireless Probe ± 2 mm 0-26
- Wireless Probe ± 5 mm,
Large Measuring Range 0-27
- Wireless Pneumatic Probe $\pm 1,5$ mm 0-28
- Wireless Pneumatic Probe ± 5 mm,
Large Measuring Range 0-29
- USB Probes ± 2 mm,
4,3 mm Range 0-30
- USB Pneumatic Probes $\pm 1,5$ mm,
3,1 mm Bolt Travel 0-31
- USB Probes ± 5 mm,
10,3 mm Bolt Travel,
Extended Measuring Range 0-32
- DC Probes ± 2 mm (Output Signal in V) 0-33
- DC Probes ± 5 mm (Output Signal in V),
with Extended Measuring Range 0-34
- DC Miniature Probes ± 1 mm
(Output Signal in V) 0-35
- Lever DC Probes $\pm 0,3$ mm
(Output Signal in V) 0-36

V-W-X-Y-Z

Vision Systems

- TESA-VISIO 200 GL P-15
- TESA-VISIO 300 GL MANUAL P-16
- TESA-REFLEX Vista Software P-19
- TESA-REFLEX Vista Compare Option P-19

QUANTITIES AND UNITS

International System of Units (SI)

F: Système international d'unités (SI)

D: Internationales Einheitensystem (SI)

Derived units (of measurement)

F: Unités dérivées

D: Abgeleitete Einheiten

Quantity	SI base unit	
	Name	Symbol
length	metre	m
mass	kilogram	kg
time	second	s
electric current	ampere	A
thermodynamic temperature	kelvin	K
amount of substance	mole	mol
luminous intensity	candela	cd

Quantity	Unit		Relationship to SI base unit
	Name	Symbol	
plane angle	radian	rad	1 rad = 1 m
frequency	hertz	Hz	1 Hz = 1 s ⁻¹
force	newton	N	1 N = 1 m kg s ⁻²
pressure	pascal	Pa	1 Pa = 1 m ⁻¹ kg s ⁻²
power	watt	W	1 W = 1 m ² kg s ⁻³
electrical potential	volt	V	1 V = 1 m ² kg s ⁻³ A ⁻¹

Decimal multiples and submultiples of the base unit "metre"

Unit	Symbol	m	cm	mm	µm	nm
kilometre	km	1 ³ m	1000 m	1 000 000 mm		
Metre	m	1 m	1 m	100 cm	1 000 mm	1 000 000 µm
decimetre	dm	10 ⁻¹ m	0,1 m	10 cm	100 mm	100 000 µm
centimetre	cm	10 ⁻² m	0,01 m	1 cm	10 mm	10 000 µm
Millimetre	mm	10⁻³ m	0,001 m	0,1 cm	1 mm	1 000 µm
tenth millimetre		10 ⁻⁴ m	0,000 1 m		0,1 mm	100 µm
hundredth millimetre		10 ⁻⁵ m	0,000 01 m		0,01 mm	10 µm
Micrometre	µm	10⁻⁶ m	0,000 001 m		0,001 mm	1 µm
tenth micrometre		10 ⁻⁷ m	0,000 000 1 m		0,000 1 mm	0,1 µm
hundredth micrometre		10 ⁻⁸ m	0,000 000 01 m		0,000 01 mm	0,01 µm
Nanometre	nm	10⁻⁹ m	0,000 000 001 m		0,000 001 mm	0,001 µm

Definition of the metre

F: Définition du mètre – D: Meterdefinition

"The metre is defined as the distance travelled by light in vacuum during a time of 1/299 792 458 of a second."

17th General Conference on Weights and Measures, 1983.

Reference temperature

F: Température de référence

D: Bezugstemperatur

For measuring instruments and workpieces, ISO R1 assesses this temperature is 20°C.

The temperature of 20°C is assumed to be valid for any size, material measure, measurement result etc., unless otherwise specified.

MEASUREMENT TASKS

Inspecting

F: Contrôler – D: Prüfen

Determining whether a test object complies with specified requirements (e.g. as regards both dimensions and form).

Measuring

F: Mesurer – D: Messen

Obtaining a value (e.g. length value) measured by comparison against a master standard (e.g. material measure).

Calibrating

F: Etalonner – D: Kalibrieren

Establishing the actual deviation of a measuring instrument from desired value.

This is usually done through measurement operations. The result of a calibration is documented in the form of a calibration certificate and can be used later on for adjustment purposes, for instance.



INDICATION RELATED DEFINITIONS

Indication

F: Indication – D: Anzeige

The indication, which provides the information about the measured value, is directly perceptible by human senses. It may be optical, acoustic or based on any other output feature.

Displaying devices may either have a digital, analogue or any other special indication.

For material measures, the indication matches displayed value.

Note: According to the standards, the terms "analogue" and "digital" are only used to differentiate the methods of measurement. Therefore, they should not be used for the definition of the indications.



Scale indication

F: Indication de l'échelle – D: Skalenanzeige

Scale indication is the readable position of a scale mark.



Line scale

F: Echelle à traits – D: Strichskale

A line scale is the successive number of graduation (scale marks) on a scale.



Scale spacing

F: Longueur d'une division (d'échelle)

D: Teilstrichabstand

Scale spacing is expressed in length units as the distance between two successive scale marks measured along the same line by a marker (e.g. the end of a pointer).

Line scales

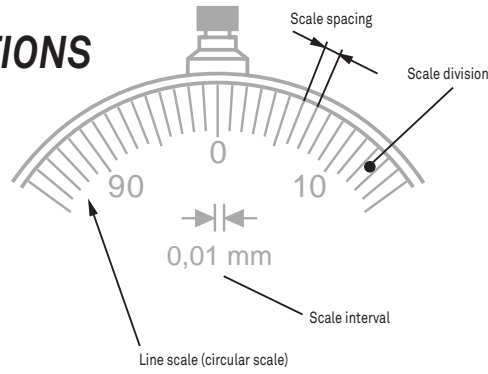
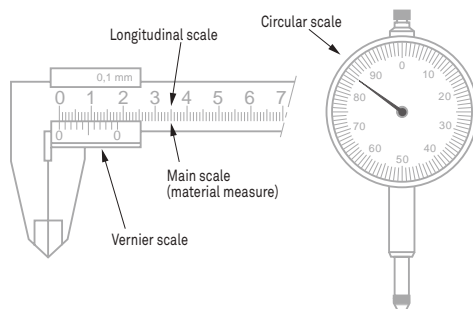

Scale division

F: Division d'échelle (échelon) – D: Skalenteil

Part of a scale between two successive scale marks.



Scale interval

F: Echelon, valeur d'une division (d'échelle)

D: Skalenteilungswert

The scale interval is the difference between the values matching two successive scale marks. This characteristic is expressed in the units marked on the scale.



Vernier interval

F: Valeur du vernier – D: Noniuswert

The vernier interval is the alteration of the value of a measurand, which in turn changes the indication by one scale division of the vernier scale.

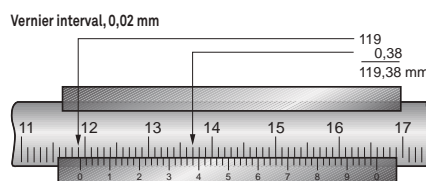
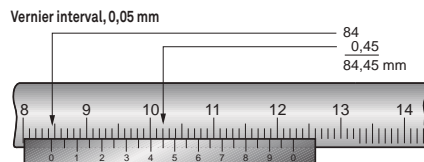

Numerical (digital) indication

F: Indication numérique

D: Ziffernanzeige

The numerical indication is shown in the form of a digit (succession of digits).



Numerical scale

F: Echelle numérique – D: Ziffernskale

A numerical scale is a succession of digits (usually 0 to 9). On a multi-scale, the single numerical scales are arranged side by side in a decimal fraction.



Numerical interval

F: Valeur du pas (échelon) numérique

D: Ziffernschrittwert

The numerical interval is the alteration by one numerical value of the indication. This characteristic, which matches the scale interval, is expressed in the units of the measurand.



METROLOGICAL DEFINITIONS



Range of indication

F: Etendue d'indication – D: Anzeigebereich
 The range of indication lies between the highest and lowest display values of a measuring instrument.



Measuring range

F: Etendue de mesure – D: Messbereich
 The measuring range of an indicating device is the range within which the measured values cannot exceed the maximum permissible errors. For tools having several measuring ranges, these errors may vary from a range to another. The measuring range may well be contained within the related whole range of indication.



Measuring span

F: Champ de mesure – D: Messspanne
 This span equals the difference between both first and last values of the measuring range as specified.



Displacement range

F: Etendue de déplacement – D: Verstellbereich
 Measurand related extent within which the measuring range can be moved.



Application range

F: Etendue d'application
 D: Anwendungsbereich
 The application range is equal to the sum of both displacement and measuring ranges.

Note: The first and last values make each range different from one another.

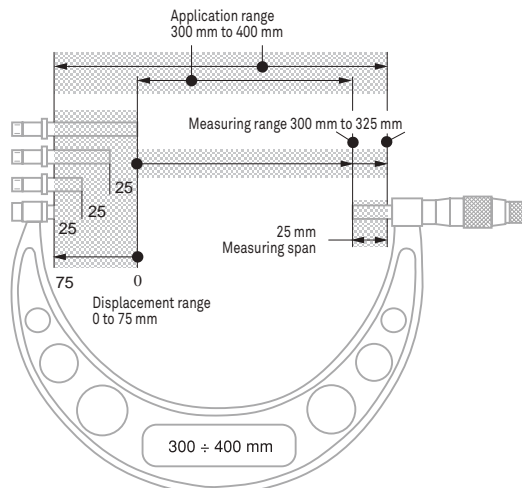

Measurand

F: Mesurande – D: Messgröße
 Physical quantity of a measurement. In other words, the measurand is the length or the angle as measured or to be measured.

Measured value

F: Valeur mesurée – D: Messwert
 Any measured value expresses the result of a measurement. Therefore, this value is directly associated with the measurand and further allocated to the output feature (e.g. display) of a measuring instrument or device. A measured value is expressed as the product of both numerical value and unit. The measured value includes the true value plus the random and systematic errors of the relevant tool.

Result of measurement

F: Résultat de mesure – D: Messergebnis
 Product of a measured value once corrected on the basis of the known systematic errors. This result is further increased by the uncertainty of measurement, which includes the random as well as any unknown systematic error.

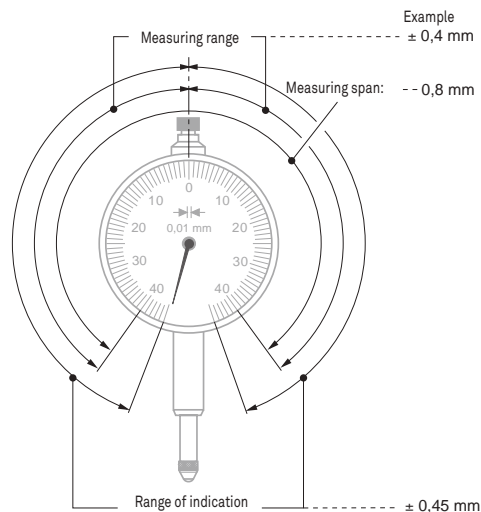
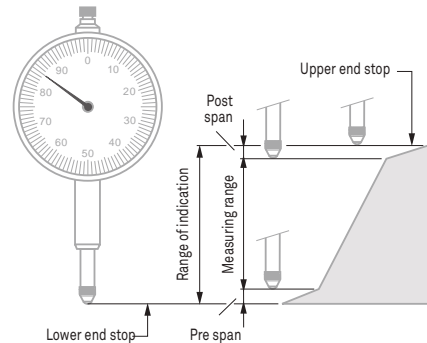
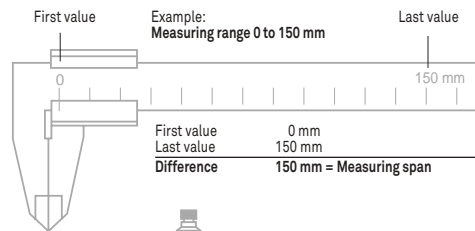

Permissible limits of a metrological characteristic MPL

F: Limites tolérées d'une caractéristique métrologique MPL

D: Grenzwerte eines Messtechnischen Merkmals MPL

Extreme permissible values of a metrological characteristic of a given measuring equipment, according to specifications or standards of the manufacturer or others.

Maximum permissible errors for a metrological characteristic MPE

F: Erreurs maximales tolérées d'une caractéristique métrologique MPE

D: Grenzwerte für Messabweichungen für ein messtechnisches Merkmal MPE

Extreme values of the permissible error for a metrological characteristic of a given measuring equipment, according to specifications or standards of the manufacturer or others.

Repeatability

F: Fidélité (répétabilité)

D: Wiederholpräzision

Ability of a measuring instrument to repeat the results obtained from the same measurand successively measured in the same direction, also under the same conditions.

Repeatability, which delivers important information for the assessment of the uncertainty of measurement, is quantitatively expressed as standard deviation of dispersion values.

Repeatability limit

F: Fidélité (répétabilité) limite

D: Wiederholgrenze

Extreme value for repeatability.

Maximum permissible errors G

F: Erreurs maximales tolérées G

D: Fehlergrenzen G

These errors are assimilated to the "Permissible limits of a metrological characteristic MPL".

Being related to both upper and lower highest deviations of a measuring instrument, they are usually symmetrical in practical metrology and, therefore, stated as single value, without any sign.

Deviation span of indication

F: Champ d'erreur d'indication

D: Abweichungsspanne

This deviation span matches the distance from the highest to the lowest point of a coordinate as shown on the relevant diagram. The value obtained is either applicable to whole or the local measuring span or measuring range.

All required measurements are carried out in one direction (without reversal of the measuring force) – i.e. with upward plunger movement for a dial gauge. For those needed to establish the whole deviation span, they are performed in both directions (with reversal of the measuring force) – i.e. with upward and downward movement of the plunger for a dial gauge.

Hysteresis

F: Hystérésis

D: (Messwert-) Umkehrspanne

Hysteresis expresses the difference between various indications of a measuring instrument.

This value is achieved through measurements of the increasing/decreasing value of the same measurand, taken under the same conditions.

Hysteresis, which is quantitatively stated as standard deviation of value dispersion, can be determined anywhere within the measuring span or range. Its amount can also be obtained from the diagram of the deviation span as a whole.

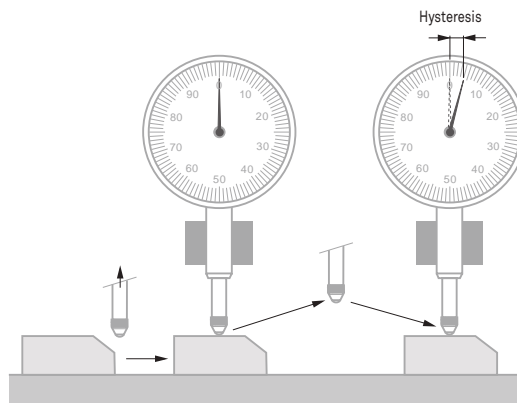
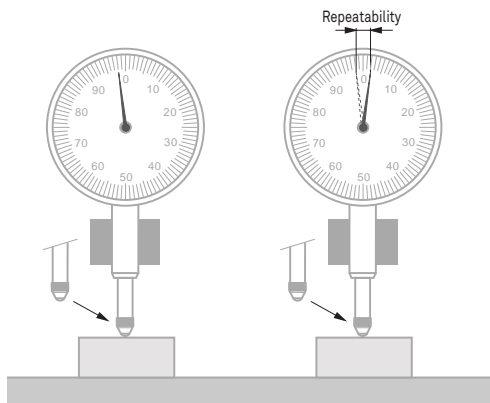



DECISION RULES FOR PROVING CONFORMANCE OR NON-CONFORMANCE WITH SPECIFICATIONS

Relationship with the uncertainty of measurement

ISO 14253-1, which is a part of "Geometrical Product Specification GPS", provides "Rules for establishing the conformance or non-conformance with specifications". These rules are valid for "Inspection by measurements of workpieces and measuring equipment".

This ISO standard makes allowances for the uncertainty of measurement – or more precisely for the true uncertainty of any measurement whenever the conformance or non-conformance with a given specification must be proved. So, for a workpiece, the specification matches a preset tolerance while being equal to the maximum permissible errors for a metrological characteristic (MPE) for a measuring instrument.

Any given specification is a constant, whereas the measurement uncertainty is a variable which is affected by many components. Therefore, the zone of conformance or non-conformance depends on the size of the effective expanded uncertainty U .

Rule for proving conformance

Conformance is proved when the measurement result y is lying within the specification zone, reduced on either side by the expanded uncertainty U . Consequently, workpieces or measuring instruments can be accepted as far as their conformance with the specification is proved by the manufacturer (supplier).

Rule for proving non-conformance

Non-conformance is proved when the measurement result y is lying beyond the specification zone, increased on either side by the expanded uncertainty U . In such a case, the relevant measuring instruments can be rejected if the purchaser (customer) gives evidence of its non-conformance.

Neither conformance nor non-conformance can be proven

This often happens when the measurement result y associated with the expanded uncertainty U includes either of the LSL or USL specification limits. As a result, workpieces or measuring instruments can neither be automatically accepted nor rejected.

For such "dead end cases", it is advisable to follow the rule below.

- Repeat all measurements based on a reduced uncertainty, so that conformance or non-conformance can clearly be demonstrated. Usually, proceeding in this way benefits to the party that's able to provide the needed proof.

- Come to a mutual agreement providing the procedure to be applied if such cases arise.

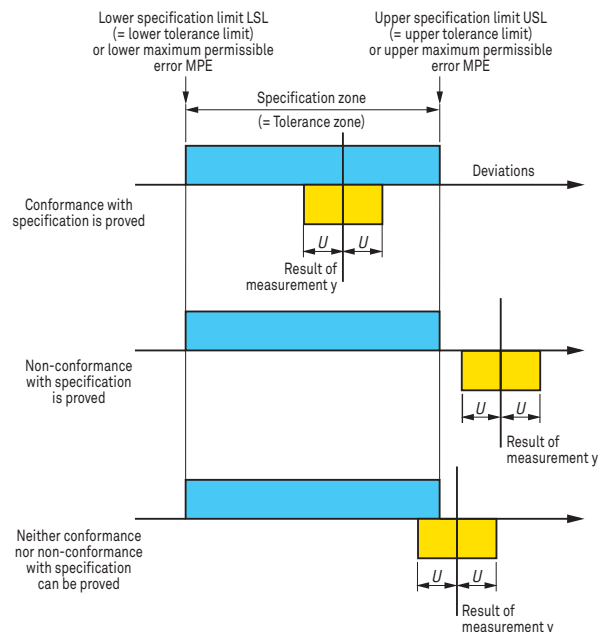
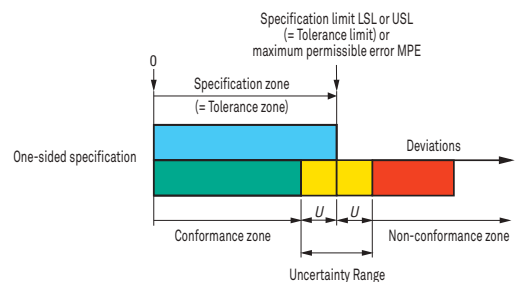
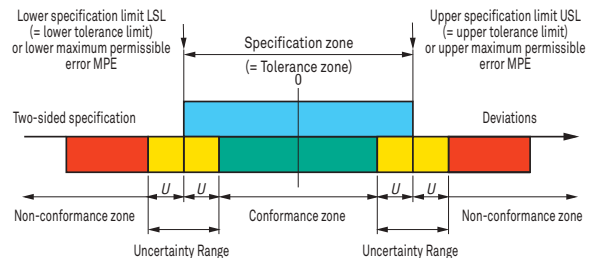

TRACEABILITY TO NATIONAL STANDARDS

All measuring equipment consistently used on our production site is traceable to national standards or reference fixtures through our quality management system.

Traceability is established by recalibration at regular intervals with documentary evidence as specified in the standards.

The illustration that follows shows the hierarchy of calibrations within the chain of traceability. The example set for the transfer of accuracy to our MICRO-HITE height gauges also shows how they are calibrated. Each feature is supplied with a free SCS calibration certificate issued by our laboratory, which is officially accredited by the Swiss Calibration Service.

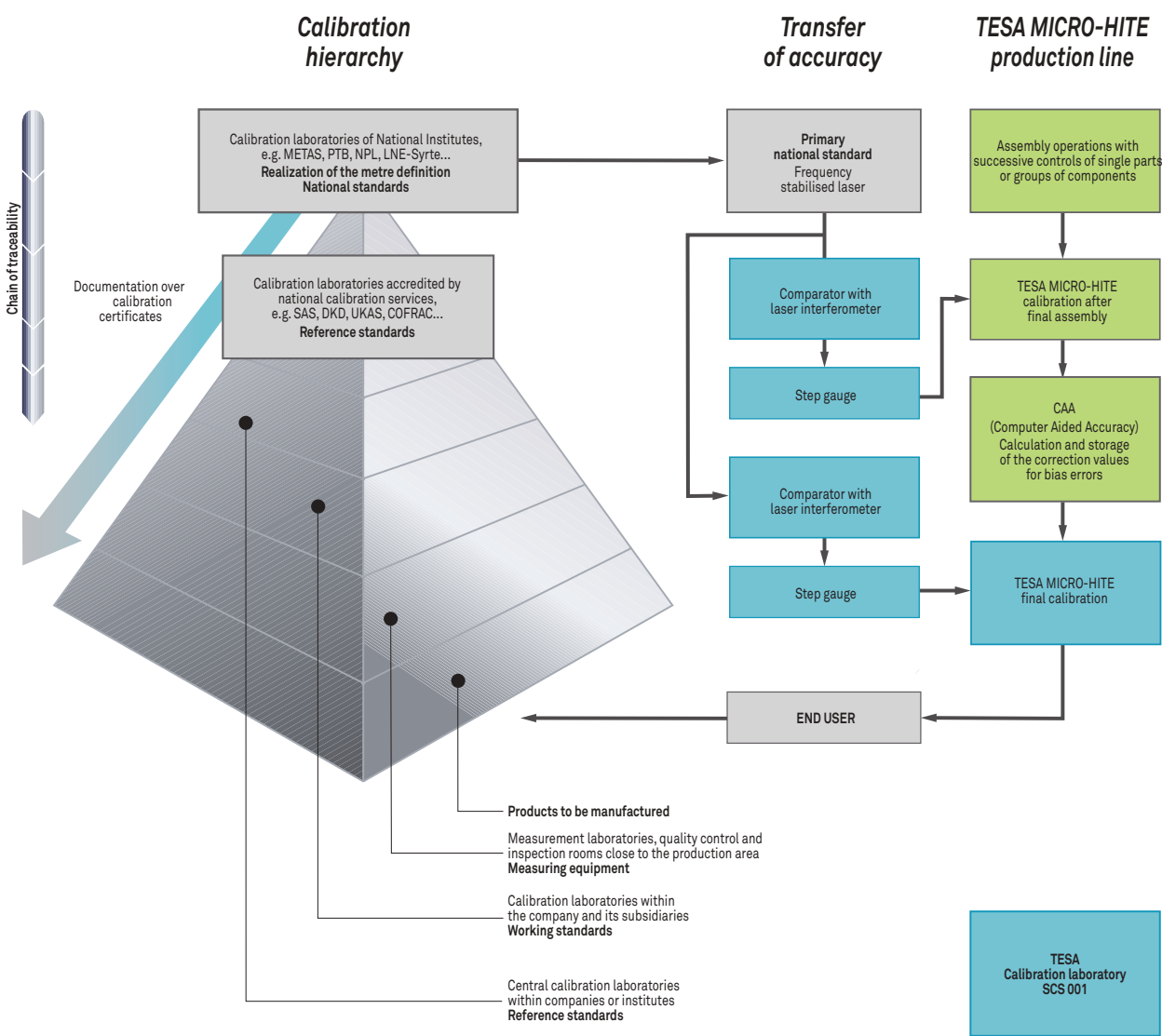

Connectivity



TESA SOFTWARE, CABLES AND LINKS FOR THE TRANSFER OF MEASURING RESULTS.

Inspection, traceability and cost reduction have a growing significance in all industrial sectors. This requires not only high quality metrology instruments, but also software suitable for evaluation and further analysis of the measurements carried out.

PRODUCTION		INSPECTION		EVALUATION	ARCHIVING	
						TESA DATA-DIRECT List of measurements, archiving, customised results calculations, traceability, statistics.
						TESA STAT-EXPRESS Statistical analysis of measurements, control charts, traceability and sharing of results.
						TESA PRINTER SPC Simple statistics, without the need for a PC, documented traceability.
		Measuring instrument or machine (VISION, SCAN or MH3D)		Software or portable printer		Database Electronic file (PDF) Printed report

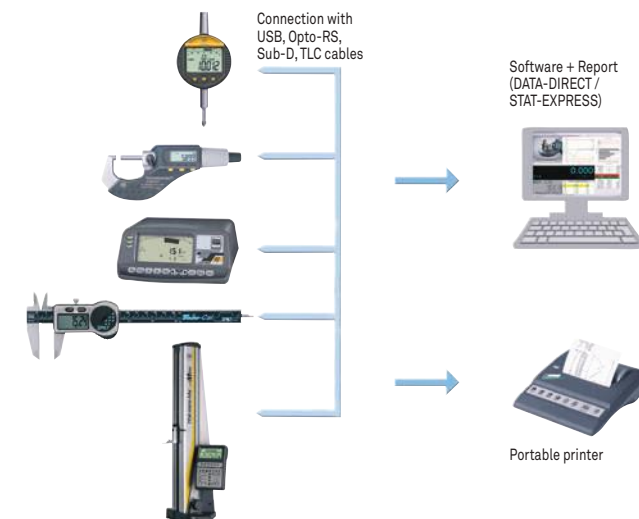

TESA offers various types of connection between measuring instruments and a PC as well as software for the management of results so that the production process can be optimised, quality improved and documents for traceability can be created.

DATA-DIRECT Software

DATA-DIRECT software is an easy way to collect and report results in real time from the majority of the measuring instruments in the TESA range that have a data output.

DATA-DIRECT is supplied not only with serial input/output drivers specially configured for TESA's products, but also for those purchased from other manufacturers. It works effectively to give data transfer for your data sheets, database, statistical modules or any other Windows-based applications.

With this user-friendly software you will be able to create your own reports for component inspection.

Minimum system requirements to run DATA-DIRECT:

- Pentium 4 or equivalent
- 512 MB RAM (live memory)
- 10 GB HD
- Windows XP, Windows 7 (32 or 64 bits)

A demonstration version can be downloaded free of charge from the TESA website at www.tesagroup.com

Date	Lot No.	Operator	Customer	Instrument	Measure	Time
12.03.2009	13.10.4678	XXX	TESA	OPTO-USB - cal IP 67	1.640	21.01.2010 12:06:06
				USB Probe GT21	-1.033	21.01.2010 12:06:06
				OPTO-USB - cal IP 67	1.640	21.01.2010 12:06:07
				USB Probe GT21	-1.033	21.01.2010 12:06:07
				OPTO-USB - cal IP 67	1.640	21.01.2010 12:06:07
				USB Probe GT21	-1.033	21.01.2010 12:06:08
				OPTO-USB - cal IP 67	1.640	21.01.2010 12:06:09
				USB Probe GT21	-1.033	21.01.2010 12:06:09
				OPTO-USB - cal IP 67	1.640	21.01.2010 12:06:10
				USB Probe GT21	-1.033	21.01.2010 12:06:10
				OPTO-USB - cal IP 67	1.640	21.01.2010 12:06:12
				USB Probe GT21	-1.033	21.01.2010 12:06:12
				OPTO-USB - cal IP 67	1.640	21.01.2010 12:06:13
				USB Probe GT21	-1.033	21.01.2010 12:06:13
				OPTO-USB - cal IP 67	1.640	21.01.2010 12:06:15
				USB Probe GT21	-1.033	21.01.2010 12:06:15

List of measured values within a third party software, e.g. MS Excel

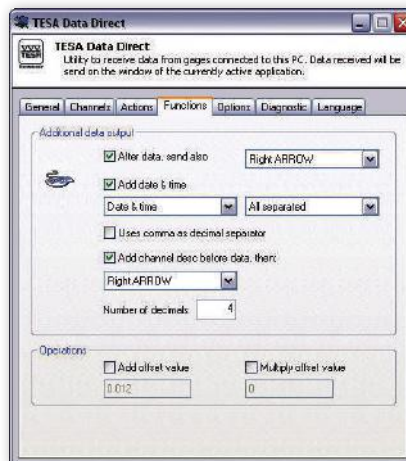

Tab function providing the facility to present the measured values



DATA-DIRECT: main window



Customisable tool bar



Real time display of the measured value in a separate window

04981001	DATA-DIRECT Software and dongle	Included in delivery
		TESA DATA-DIRECT installation CD with licence key (dongle) USB and user instructions (PDF version)

TESA DATA-DIRECT Software	
TESA Instruments compatible with DATA-DIRECT	OPTO-RS Cables – OPTO-USB Cables – Height gauges (TESA-HITE, MICRO-HITE) – USB probes – Surface roughness gauges RUGOSURF 10 / 20 / 10G / 90G – TESA MICRO-HITE 3D Reflex machines – TESA-SCOPE TS300 – TPS presetting bench – BPX probe interface – TWIN-STATION wireless probe interface – TESA wireless systems – TLC-TWIN wireless transceiver
Other instruments compatible with DATA-DIRECT	Custom made instruments with RS232 output – Instruments from other makers: Mitutoyo: DMX3 - DMX8 – Steinwald single 6 – Etc.
Functions	Export of results to .csv file – ASCII commands – Real time display of measured results on a PC (except for models using the Rf-USB receiver)



STAT-EXPRESS Software

STAT-EXPRESS is a dedicated software package that enables the application of quality assurance into your manufacturing processes. It allows the downloading, reporting, transfer and storage of your quality-oriented control charts.

STAT-EXPRESS is compatible with all TESA's products – from calipers through to CMM or Vision machines. As an integrated software tool, STAT-EXPRESS provides the flexibility required for easy data transfer from most of the electronic gauges currently available on the market.

STAT-EXPRESS offers the ability to create reports including measured values obtained from a single instrument or several handtools, assign tolerances, calculate statistics, print out various measurement reports, compute XR control charts, and much more.



Measuring display with the option of adding operational instructions, accompanied with a photo or drawing

Minimum system requirements to run STAT-EXPRESS:

- Pentium 4 or equivalent
- 512 MB RAM (live memory)
- 10 GB HD
- Windows XP, Windows 7 (32 or 64 bits)

A demonstration version can be downloaded free of charge from the TESA website at www.tesagroup.com



Simultaneous data acquisition from several measurement programmes

XR Control chart

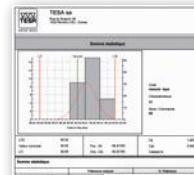

Detailed measuring report for each feature measured



Detailed measuring report for each part measured, together with serial number

No	=	Included in delivery
04981002	STAT-EXPRESS software and dongle	TESA DATA-DIRECT installation CD with USB licence key (dongle) and user instructions (PDF version)
04981004	STAT-EXPRESS Machine software and dongle	Installation CD with USB licence key (dongle) and user instructions (PDF version)

STAT-EXPRESS Software	
TESA instruments compatible with STAT-EXPRESS	OPTO-RS cables – OPTO-USB cables – Height gauges (TESA-HITE, MICRO-HITE) – USB probes – Surface roughness gauges: RUGOSURF 10 / 20 / 10G / 90G – TESA MICRO-HITE 3D Reflex machines – TESA-SCOPE TS300 – TPS presetting bench – BPI Probe interface– BPX probe interface – TWIN-STATION wireless probe interface – TESA wireless systems – TLC-TWIN wireless emitter-receiver
Other instruments compatibles with STAT-EXPRESS	Custom made instruments with RS232 output – Instruments from other makers: Mitutoyo: DMX3 - DMX8 – Steinwald single 6 – etc.
Features	DATA-DIRECT included – Export of results to .csv file – Import of .csv files – Table of all measured results – XR control charts – Report by part measured – Report by feature measured – Simultaneous data acquisition – Overall report with statistics – Measuring report in .pdf or .html format etc.– Security protection set for each user

USB Accessories: Adaptor Sub-D 9p/m/USB, Multiplexer USB, Foot Switch USB



S47120002



S47120003



04761071

No	=	L, m	Connector (to PC or system)
S47120002	USB-D-Sub 9p/m adapter cable	0,1	USB
S47120003	USB multiplexer with 7 USB 2.0 ports. with external power supply, Max 4x 04761062 and 04761063.		USB
04761071	USB footswitch. For simultaneous data request from DATA-DIRECT or STAT-EXPRESS software of all connected instruments	2	USB



TESA Portable SPC PRINTER

TESA portable intelligent printer designed for the inspection of finished parts or incoming goods – Provides SPC statistics and prints out measurement results with graphical representations.

The TESA SPC PRINTER can be connected not only to TESA measuring instruments, but also to those provided with a DIGIMATIC output – Your TESA SPC PRINTER is capable of recognising the plug in tool and will execute the appropriate configuration automatically.



TESA SPC Printer

- Memory capacity : 9999 single values for one feature per sample.
- Two operating modes: «Normal» and «Tolerance».
- Limits of size quickly set on the display of the connected instrument with subsequent transfer to TESA PRINTER SPC.
- Output of statistical values printed out with graphical representations.
- Output of reports with headings to be filled in by the operator.
- Hardcopies printed in preferred language (English, German, French, Italian or Spanish).
- Battery-powered (6 V) printer unit for use on the move (optional).

No	=
06430000	SPC PRINTER EU Portable. With memory, SPC, value classification and graphs. RS232 interface
<i>DELIVERED WITH THE FOLLOWING ACCESSORIES:</i>	
04765013	Roll of printer paper, width = 110 mm for TESA SPC Printer
04761054	Mains adapter /battery charger 100 ÷ 240 VAC 50 ÷ 60 Hz, 6,6 Vdc, 750 mAh supplied without cable
04761055	EU Mains cable for 04761054 adapter
<i>OPTIONAL ACCESSORIES:</i>	
04761056	USA Mains cable
04768035	Battery charger 6V, 0,5AH

- 180 x 180 x 84 mm (W x D x H)
- Paper width: 110 mm. Print mode: 40 signs/line
- RS232 for data inputs (9-pin male, trapezoid connector) DIGIMATIC (Anselly connector, 10-pin) Connector with mini-jack for remote triggering of data transfer
- Mains adapter 100 to 240 Vac, 6,6 Vdc. Optional accessory: 6 V rechargeable battery pack.
- 10°C to 40°C
- 10°C to 60°C
- IP40 (IEC 60529)
- EN 50081-1, EN 50081-2, EN 50082-1, EN 50082-2
- 0,55 kg
- Packed suitable for shipping
- Serial number
- Declaration of conformity

	"Normal" Mode	"Tolerance" Mode
Lower size limit (min.)	–	●
Upper size limit (max.)	–	●
Tolerance	–	●
Number of values taken:		
number of samples	●	●
< smallest dimension	–	●
> largest dimension	–	●
% out of tolerance	–	●
Lowest value listed	●	●
Highest value listed	●	●
Dispersion R	●	●
Arithmetical mean	●	●
Standard deviation sn, sn-1	●	●
Indication of capacity Cp, Cpk	–	●
Graphical representations:		
Position of each single value within the tolerance zone (10 classes)	–	●
Graphical representations:		
Histogrammes	–	●
Display (LED) - Classification of the value measured: Green for pass, yellow for rework, red for reject	–	●



1 x CR2032 3,0 V,
230mAh



12 months. Can
be influenced by
battery level.



- 10°C to 60°C
Humidity max 80%
without conden-
sation



10°C to 40°C.
Humidity max 80%
without conden-
sation



EN 61326-1
EN 61000-4-3
ROHS, according to
2002/95/CE
EMC, according to
2004/108/CE
DEEE, according to
2002/96CE
REACH 1907/2006
ETSI EN 300 440 - 2
(CH et EU)
CFR and FCC 15.249

Wireless Connection for TWIN-STATION Receiver

The ultimate in flexibility and freedom of movement.

TESA TLC-TWIN wireless technology offers the flexibility of a hand tool thanks to bidirectional communication made possible by an instrument equipped with a TLC (TESA Link Connector) also compatible with the:

- TLC-TWIN-emitter/receiver station
- TLC-USB connecting cable
- TLC-Digimatic connecting cable.

*** The sale of the TLC-TWIN is currently restricted to EU countries, Switzerland USA and Canada

*** Please contact TESA for further information.

Up to 48 instruments can be managed by the TWIN-STATION receiver over a maximum range of 12 m.

The IP67 degree of protection of an instrument is preserved, even when the TLC-TWIN is connected.

When a visual check that the measured result has been sent to the computer is not possible, an indication on the display of the instrument enables the user to confirm that the result has been sent and received.



TESA IP67 caliper used
with a TLC-TWIN

TLC-TWIN Wireless
emitter-reciever
(04760180)



No	=	Operating range, m	Compatible with connector	Diameter, mm	Weight, g
04760180	TESA TLC-TWIN wireless emitter-receiver. Compatible with any instrument fitted with a TLC (TESA Link Connector)	~ 12 (dependent on conditions)	TLC (TESA Link Connector)	Ø 28	~ 10

OPTIONAL ACCESSORIES:

05030012	TWIN-STATION BPW Probe box
04981001	DATA-DIRECT software and dongle
04981002	STAT-EXPRESS software and dongle



TWIN-STATION Receiver

TWIN-STATION: Receiver for wireless TLC-TWIN emitter-receiver units
 Receives input signals from wireless TLC-TWIN emitter-receiver units
 Output signals – digital, RS232

- Direct connection to a PC via the USB port.
- Optimal use for your measuring tasks as up to 48 instruments equipped with TLC-TWIN can be connected to this unit.
- Great reliability.

*** the sale of TWIN-STATION is currently limited to EU countries, Switzerland, USA and Canada
 *** Please contact TESA for further details.



TWIN-STATION (front view)

TWIN-STATION (rear view)

No	=	A	⚙️	📦
05030012	TWIN-STATION for TLC-TWIN wireless data transmission	Number of instruments with TLC-TWIN 48	Power supply Power supply via: - USB port of the PC - connected USB hub - USB hub of the BPX interface	Weight, kg 0,85

- Housing case in aluminium
- Power supply via the connection of the USB cable: - directly to the PC (USB Port) to a mains powered USB hub
- 10°C to 60°C
- 10°C to 40°C
- 80%, non-condensing
- IP 40 (IEC 60529) (DIN 40050)
- IEC/EN 61326-1 U.S. 47 CFR part 15, subpart B, Class B digital device
- Packed suitable for shipping
- Declaration of conformity
- Serial number identification
- Data transfer delay from digital serial output (USB): depends on the operating system of the computer.
- RS232
- 55 x 172 x 155 mm (H x W x D)
- USB Cable 1,80 m
- 0,85 kg
- For a temperature of 20° C and a relative humidity of ≤ 50%: Digital output: ± (0,05 + 0,15% of the measuring range)

NEW: Transfer of Results with TESA LINK CONNECTOR TLC

TESA presents its new connectivity concept: the TLC connector that allows freedom of movement, flexibility, and ease of use, all combined.

Once an instrument is equipped with a TLC connector:

- 1) There is no longer any need to choose between a model with or without data output.
- 2) There is inbuilt compatibility for both cable and wireless connectivity.
- 3) A TLC connector can also be used for connection to a USB interface, a DIGIMATIC interface or for wireless connection, using a suitable cable or emitter-receiver unit, see table below:

Instrument equipped with a TLC connector. For example, TESA TWIN-CAL IP67 caliper



Wireless connection	Cable connection	
TLC-TWIN Two way wireless emitter-receiver unit	TLC-USB Two way communication cable	TLC-DIGIMATIC Two way communication cable
+	+	+
TWIN-STATION receiver base station for signals from the wireless TLC emitter-receiver unit	Interface with USB port	DIGIMATIC* interface
Personal computer		

* Please check with TESA for the list of equipment and instruments compatible with TESA-DIGIMATIC



OPTO AND SUB-D CONNECTION

Standard OPTO Connection







Any connecting cable is defined by each of the connectors fitted at either end of the cable principally to suit the computer, and the measuring instrument being used. To achieve highest compatibility levels, TESA uses only standardized and proven connectors.

Examples of instruments with type Opto connector:

TESA-CAL IP67 / IP65 – TESA MICROMASTER – TESA IMICRO –
TESA ALESOMETRE – TESA DIGICO 10 / 11 / 205 / 305 / 400 / 500 / 600 / 705 –
TESATRONIC TT20 / TT60 / TT80 / TT90 – INTERAPID - Light

No	=			
		L, m	Connection (to instrument)	Connection (to PC or system)
04761062	Opto-USB cable, duplex, bidirectional communication	2	Opto-RS232	Type A USB
04761046	Opto-RS cable, simplex, 2 m, one way communication: from the instrument to the PC	2	Opto-RS232	Sub-D 9p/f Simplex
S47010022	Opto-RS cable, simplex, 5 m, one way communication: from the instrument to the PC	5	Opto-RS232	Sub-D 9p/f Simplex
04761049	Opto-RS cable, duplex, 2 m, bidirectional communication	2	Opto-RS232	Sub-D 9p/f Duplex
S47010024	Opto-RS cable, duplex, 5 m, bidirectional communication	5	Opto-RS232	Sub-D 9p/f Duplex
04761027	Connecting cable without connector	2	Opto-RS232	Without connector





Current systems	Compatible connectors	
		
TESA PRINTER SPC	Sub-D 9p/f	Ansley 10p/f
		
Computer	USB	Sub-D 9p/f

Standard Sub-D Connection

RS232, Sub-D 9p/m connector connecting cables for the following machines or precision handtools: TESA MICRO-HITE / TESA-HITE / TESA- μ HITE / TESA TG / 3D Machines



No	=			
		L, m	Connector (to instrument)	Connector (to PC or system)
04761063	Sub-D 9p/m to USB cable, 2M	2	Sub-D 9p/m	USB
04761052	Extension cable, Sub-D 9p/f to 9p/m, 2 m	2	Sub-D 9p/m	Sub-D 9p/f
S47010025	Extension cable, Sub-D 9p/f to 9p/m, 10 m	10	Sub-D 9p/m	Sub-D 9p/f
S47120002	Sub-D 9p/m to USB adapter cable	0,1	Sub-D 9p/m	USB

Connecting Cables from the Instrument to a PC or Computer Controlled System



04760181



04760182



Instrument connection: special CLINOBEVEL



04761038



Instrument connection: special DIGICO 12



PC/system connection: Ansley 10p/f



Instrument connection: MiniDIN 8p/m



Instrument connection: Special for DIGICO 1 or 2

No	=	L, m	Connection (to instrument)	Connection (to PC or system)
04760181	TESA TLC-USB CABLE for instruments with a TLC connector	2	TLC (TESA Link Connector)	USB
04760182	TLC-DIGIMATIC CABLE for instruments with a TLC connector	2	TLC (TESA Link Connector)	Ansley connector 10 pin/f
04761023	Cable: miniDIN 8p/m to Sub-D 9p/f, 2 m for TT10 and MICRO-HITE manual versions 10/11/12	2	MiniDIN 8p/m	Sub-D 9p/f
04761024	Cable: miniDIN 8p/m to Sub-D 25p/m, 2 m for TT10 and MICRO-HITE manual versions 10/11/12	2	MiniDIN 8p/m	Sub-D 25p/m
04761038	Cable: miniDIN 8p/m to Sub-D 25p/m for DIGICO 1 and 2, with powered display	3	Special connector for DIGICO 1 or 2	Sub-D 25p/f
S47078588	Cable for DIGICO 1 or 2 and TESA SPC printer	2	Special connector for DIGICO 1 or 2	Ansley connector 10 pin/f
04761060	RS232 cable with external power supply	2	Specially for DIGICO 12 and TESA IP65 electronic lever type dial test indicators	Sub-D 9p/f
03969007	RS232 Sub-D 9p/f to Sub-D 9p/f, 3 m cable for TESA-REFLEX MH3D, TESA-SCOPE	3	Specially for DIGICO 12 and TESA IP65 electronic lever type dial test indicators	Sub-D 9p/f
S53300165	USB Cable for CLINOBEVEL 1 L = 1,8 m	1,8	Special connector for CLINOBEVEL 1	USB
S53070174	USB Cable for CLINOBEVEL 2 L = 2,5 m	2,5	Special connector for CLINOBEVEL 2	Sub-D 9p/f

Hand / Foot Switches, Adapters, Battery Chargers, Power Cables



04768001



04768000





04761054



04761017



S47001891

				
		L, mm	Connection (to instrument)	Connection (to PC or system)
04768000	Hand switch for triggering data transfer. Jack plug, 1,8 m – to TESA SPC PRINTER – to TESATRONIC (TT) display units	1,8	–	Jack plug
04768001	Foot switch for triggering data transfer. Jack plug, 1,8 m – to TESA SPC PRINTER – to TESATRONIC (TT) display units	1,8	–	Jack plug
04761017	Adapter ADP-01 Sub-D 9p/f to Sub-D 25p/m		–	–
S47001891	DIGIMATIC adapter for 04761046 cable Sub-D 9p/m to Ansley 10p/f	0,2	–	Sub-D 9p/f or Ansley 10p/f
04761054	Mains adapter /battery charger 100 ÷ 240 VAC, 50 ÷ 60 Hz, 6,6 Vdc, 750 mAh, supplied without cable	2	DC-Jack	–
04761055	EU mains cable for 04761054	1,5	–	–
04761056	USA mains cable for 04761054	1,5	–	–
04761037	Mains cable 230V for DIGICO 1 or 2	2	Special connector for DIGICO 1 or 2	–
04761057	Mains cable 110V for DIGICO 1 or 2	2	Special connector for DIGICO 1 or 2	Sub-D 9p/f



Connecting Cables for RUGOSURF to PC or Printer

Connecting cables for RUGOSURF roughness gauges



04760099



06960062 version 3



058213



056109



04760099	Cable RUGOSURF 20 to PC
06960062	Cable RUGOSURF 10G and RUGOSURF 90G to PC (connector v3)
058213	Connecting cable RUGOSURF 20 to dot matrix printer
056109	Connecting cable RUGOSURF 10G and RUGOSURF 90G to dot matrix printer

Calipers



THE ESSENTIALS

Calipers are the most popular length measuring instruments used worldwide. Owing to their simple construction, ease of handling and quick operation, they are a favourite for dimensional measurement. The wide variety of models available with specialised measuring faces make them universal hand-held tools.

All TESA, ETALON, INTERAPID branded calipers are recognised for their superior quality – and guarantee you precise measurement. The flawless guide of the slider on the beam ensures silky-smooth operation whilst also preventing the measuring jaws from tilting.

The choice of material, subjected to precisely defined heat treatment as well as a robust design result in further distinctive advantages such as wear and corrosion resistance.

For quick and easy reading of measured values – one of the essential conditions for the assurance of your measurements – we offer conventional vernier models as well as dial models for easy reading and digital models for error-free reading.

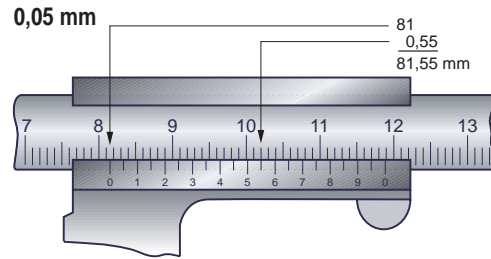
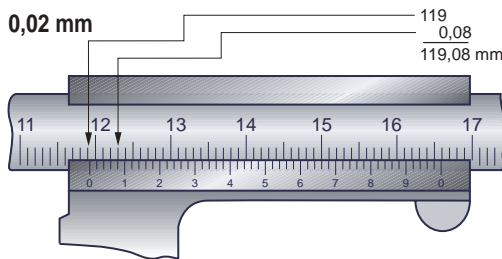

Chosen Length L mm	0,1 mm 0,05 mm	0,02 mm	0,01 mm
	µm	µm	µm
50	50	20	20
100	50	20	20
150	50	30	30
300	50	30	30
400	60	30	30
500	70	30	30
600	80	30	30
700	90	40	40
800	100	40	40
900	110	40	40
1000	120	40	40
1200	140	50	
1400	160	50	
1600	180	60	
1800	200	60	
2000	220	60	

The max. permissible errors (G) are expressed by the equation given below, where the values should be rounded down to two decimal fractions (0,01 mm). These errors apply for measurements taken under the same measuring force. For all other measurements, including those performed with use of the depth foot, the values obtained have to be increased by 20 µm.

Calipers with dial or vernier reading to 0,1 or 0,05 mm :
 $G = (20 + l / 10 \text{ mm}) \mu\text{m} \geq 50 \mu\text{m}$

Calipers with analogue indication (scale or vernier reading to 0,02 mm) or digital indication :
 $G = (22 + l / 50 \text{ mm}) \mu\text{m}$

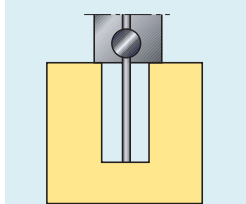
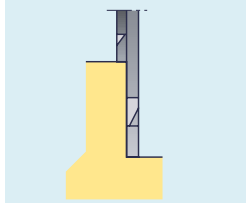
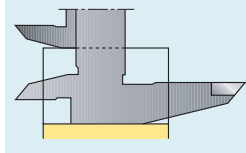
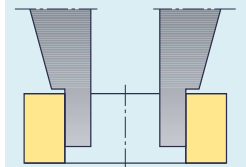
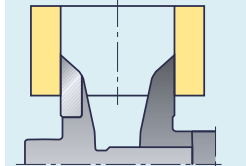
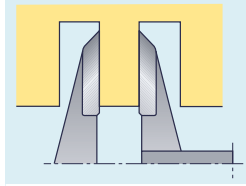
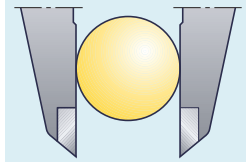

- +
- ISO 13385-1
- 0,01 mm / 0.0005 in
- LCD, 11 mm
- Floating zero
- mm / in conversion
- ≤ 100 mm: 20 µm
≥ 100 mm: 30 µm
- 10 µm
- Scale with incremental divisions, inductive
- 2,5 m/s
- TLC Connectivity
- Stainless steel
- Lithium battery, 3V, CR2032
- 12.000 hours
- Standby mode after 10 minutes, instrument retains the zero position. Automatic shut off after 2 hours, instrument retains the zero in ABS mode, but the zero must be reset if the instrument is in DIFF mode.
- 10°C to 60°C
- 10°C to 40°C
- 100 %
- IP67
- 1907/2006/CE
2004/108/CE
2002/96/CE
- Plastic storage case
- Inspection report and declaration of conformity
- Serial number identification

TWIN-CAL IP67

Welcome to the new generation of TESA electronic calipers, with the highest degree of protection ever offered.

The TWIN-CAL IP67 are all equipped with TLC (TESA Link Connector), the unique integral data output facility, providing the opportunity to upgrade your caliper at any time.

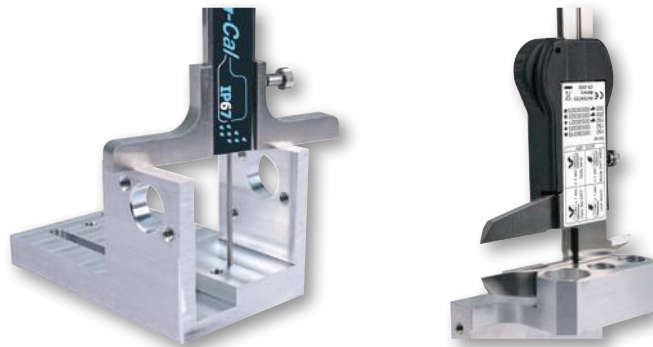
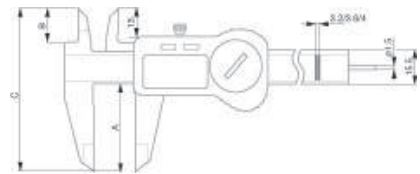

No	mm	in	Drive system / Thumb Roller	A mm	B mm	C mm	g	Depth rod
00530319	150	6	–	40	16	74	150	Square
00530320	150	6	–	40	16	74	150	Round
00530321	150	6	With	40	16	74	150	Round
00530322	200	8	With	50	20	90	200	Square
00530323	300	12	With	64	22	106	280	Square

OPTIONAL ACCESSORIES:

- 00560013 Depth foot for calipers up to 150 mm
- 01961000 Lithium battery, 3V, CR2032
- 04760180 TESA TLC-TWIN wireless emitter-receiver
Compatible with any instrument fitted with a TLC – TESA Link Connector
- 04760181 TESA TLC-USB cable for instruments with a TLC connector
- 04760182 TLC-DIGIMATIC cable for instruments with a TLC connector



TWIN-CAL IP40

The new TWIN-CAL calipers are all supplied with a built in data output port. Simply plug the TESA TLC connector into the TWIN-CAL and the other end into a PC and all your measurement results will be captured and stored for optimal SPC monitoring.



No	mm	in	Drive system / Thumb roller	A mm	B mm	C mm	g	Depth rod
00530094	150	6	With	40	16	74	150	Round
00530097	150	6	-	40	16	74	150	Square
00530095	200	8	With	50	20	90	200	Square
00530096	300	12	With	64	22	106	280	Square

OPTIONAL ACCESSORIES:

00560013	Depth foot for calipers up to 150 mm
01961000	Lithium battery, 3V, CR2032
04760180	TESA TLC-TWIN wireless emitter-receiver Compatible with any instrument fitted with a TLC – TESA Link Connector
04760181	TESA TLC-USB cable for instruments with a TLC connector
04760182	TLC-DIGIMATIC cable for instruments with a TLC connector

- ISO 13385-1
- 0,01 mm / 0.0005 in
- LCD, 11 mm
- Floating zero
- mm/in conversion
- ≤ 100 mm: 20 µm
>100 mm: 30 µm
- 10 µm
- Scale with incremental divisions, inductive
- 2,5 m/s
- TLC connectivity
- Stainless steel
- 3V Lithium battery, CR2032
- 12.000 hours
- Standby mode after 10 minutes, instrument retains zero. Automatic shut off after 2 hours. The instrument retains zero in ABS mode, but if the instrument is in DIFF mode, the zero must be reset.
- 10°C to 60°C
- 10°C to 40°C
- 80 %
- IP40
- 1907/2006/CE
2004/108/CE
2002/96/CE
- Plastic storage case
- Inspection report with declaration of conformity
- Serial number identification

TESA VALUeline IP40

TESA VALUeline, a brand designed by TESA to meet the demands of users looking for affordable products, but not willing to compromise on TESA know-how. The Swiss technology at the heart of our products offers additional quality assurance.

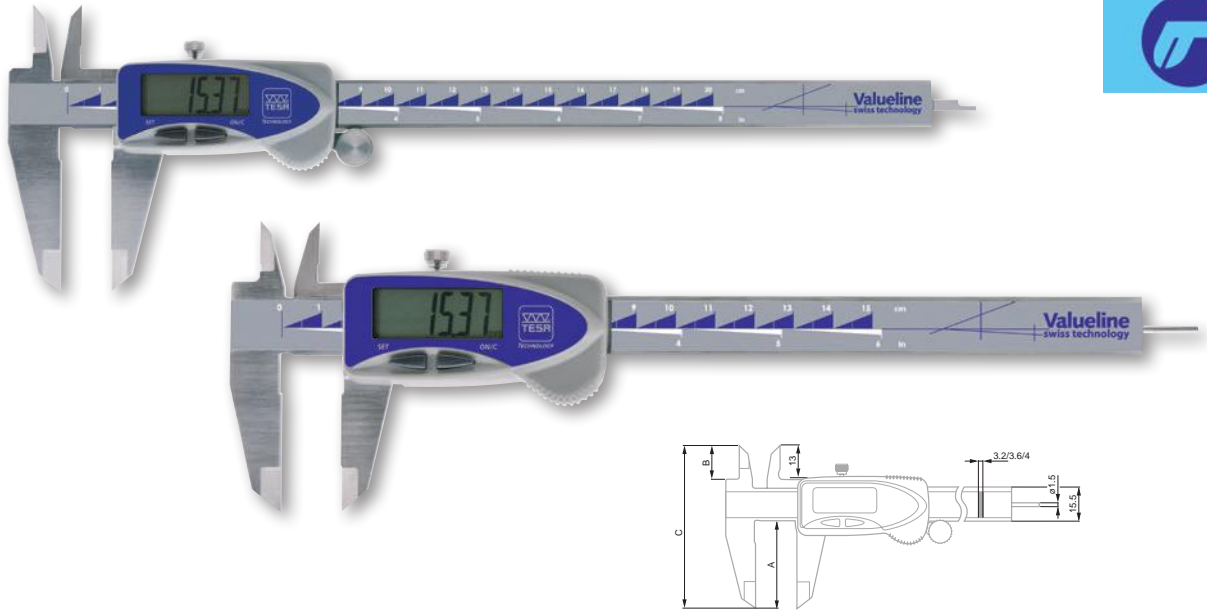

- ISO 13385-1
- 0,01 mm / 0.0005 in
- LCD, 11 mm
- Floating zero
- mm / in conversion
- ≤ 100 mm = 20 µm
≥ 100 mm = 30 µm
- 10 µm
- Scale with incremental divisions, capacitive
- 1,6 m/s
- Stainless steel
- 3V Lithium battery, CR2032
- 1.5 to 2 years
- Standby mode after 10 minutes, instrument retains zero. Automatic shut off after 2 hours. The instrument retains zero in ABS mode, but if the instrument is in DIFF mode, the zero must be reset.
- 10°C to 60°C
- 10°C to 40°C
- 80 %
- IP40
- 1907/2006/CE
2004/108/CE
2002/96/CE
- Plastic storage case
- Inspection report with declaration of conformity
- Serial number identification

No	mm	in	Drive system/ thumb roller	A mm	B mm	C mm	g	Depth rod
00539090	150	6	-	40	16	74	150	Square
00539091	150	6	-	40	16	74	150	Round
00539092	200	8	With	50	20	90	200	Square
00539093	300	12	With	64	22	106	280	Square

OPTIONAL ACCESSORIES:

01961000	Lithium battery, 3V, CR2032
00560013	Depth foot for calipers up to 150 mm



DIAL CALIPERS

Rugged construction – High accuracy – Patented shockproof design – Ideal for use in the workshop.

Models TESA CCMA-M

Easy-to-read dial calipers – Slider with metal dial housing – Models with a 200 or 300 measuring span are fitted with a thumb roller.

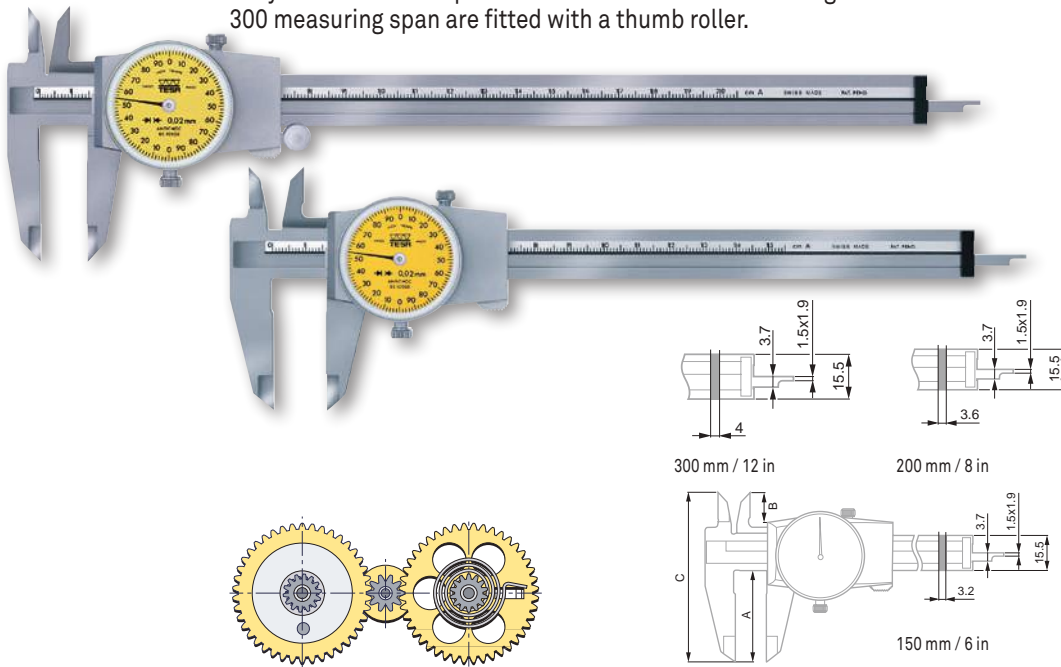

	Thumb roller	A mm	B mm	C mm				
00510008	0 ÷ 150 mm	0,02 mm	2 mm	–	40	13	74	
00520002	0 ÷ 6 in	0,001 in	0.1 in	–	40	13	74	
00510045	0 ÷ 200 mm	0,02 mm	2 mm	●	50	18,6	89,5	
00510046	0 ÷ 300 mm	0,02 mm	2 mm	●	64	20,6	105,5	

OPTIONAL ACCESSORY:
00560013 Depth foot for calipers up to 150 mm

Model TESA CCMA-M, 0,01 mm

Slider with metal dial housing – 1 mm per dial revolution.

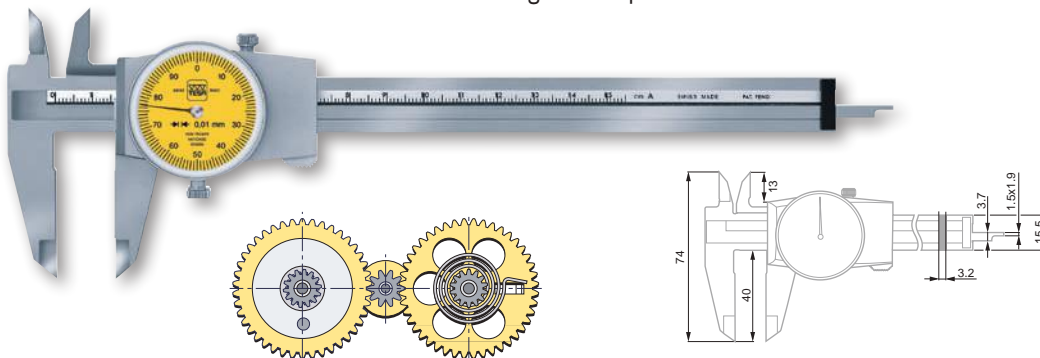

	mm	mm	mm	
00510050	0 ÷ 150 mm	0,01		

OPTIONAL ACCESSORY:
00560013 Depth foot for calipers up to 150 mm

- DIN 862 (Style 1AR)
- ≤ 100 mm = 20 µm
>100 mm = 30 µm
- Gear mechanism made of hardened ground steel
- Hardened stainless steel
- Plastic storage case
- Inspection report with a declaration of conformity
- Serial number identification
- 32 mm diameter rotating dial with lock
- Slider with locking screw
- Patented shockproof design

- DIN 862 (Style 1AR)
- ≤ 100 mm = 20 µm
>100 mm = 30 µm
- Gear mechanism made of hardened ground steel
- Hardened stainless steel
- Plastic storage case
- Inspection report with a declaration of conformity
- Serial number identification
- 32 mm diameter rotating dial with lock
- Slider with locking screw
- Patented shockproof design



N DIN 862 (Style 1AR)

≤ 100 mm = 20 μm
 >100 mm = 30 μm

Gear mechanism made of hardened, ground steel

Hardened stainless steel

Plastic storage case

Inspection report with a declaration of conformity

No Serial number identification

32 mm diameter rotating dial with lock

A Slider with plastic dial housing and locking screw

Patented shockproof design

TESA CCMA-P Models

Quick and easy to read – Slider with plastic dial housing.

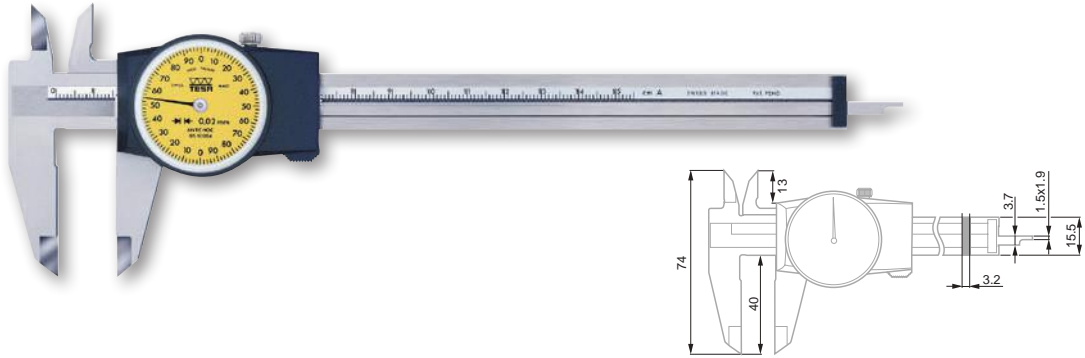

00510004	0 ÷ 150 mm	0,02 mm	2 mm	Without thumb wheel
00520001	0 ÷ 6 in	0.001 in	0.1 in	Without thumb wheel

OPTIONAL ACCESSORY:

00560013 Depth foot for calipers up to 150 mm



N DIN 862 (Style 1AR)

≤ 100 mm = 20 μm
 >100 mm = 30 μm

Gear mechanism made of hardened, ground steel

Hardened stainless steel

Plastic storage case

Inspection report with a declaration of conformity

No Serial number identification

32 mm diameter rotating dial with lock

A Slider with locking screw

Patented shockproof design

ETALON 125 Model

Slider with metal dial housing – 1 mm travel per dial revolution.

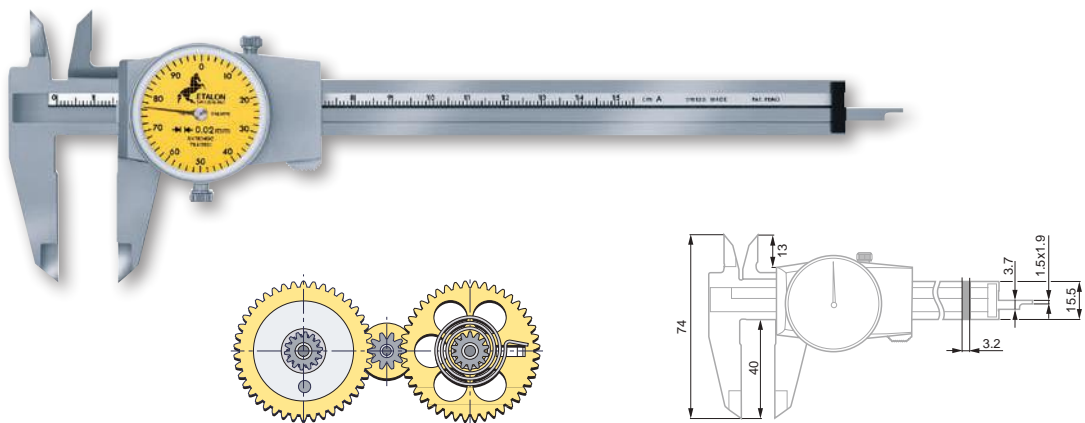

075115821	0 ÷ 150 mm	0,02 mm	1 mm	Without thumb wheel
-----------	------------	---------	------	---------------------

OPTIONAL ACCESSORY:

00560013 Depth foot for calipers up to 150 mm







ACCESSORIES FOR CALIPERS

Accessories for standard calipers

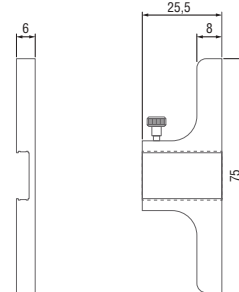
Depth Measuring Foot

For use with TESA or ETALON universal calipers with a measuring span of 0 to 150 mm / 0 to 6 inch.



		
00560013	Depth foot for calipers up to 150 mm	75 x 6



Factory standard



Hardened stainless steel





Ground measuring face

Magnetic Magnifying Glass

Can be mounted on calipers and other such instruments for easier reading of vernier scales.



		
0051610365	Magnetic magnifying glass, 3x magnification	



Plastic pouch



2 permanent magnets



DIN 862
(Style 1AN-2)
NFE 11-091



Maximum
permissible errors,
in accordance with
standard



Hardened stainless
steel



Plastic storage
case



Inspection report
with a declaration
of conformity



Serial number
identification



Satin-chrome scale
background; main
scale slightly set
back for protection
against wear

VERNIER CALIPERS

The simplest calipers to use with engraved scales for reading very fine divisions on measurements.

Standard Models

Calipers offering great value for money:

- Fitted with a locking screw.
- With rectangular or round depth rod.

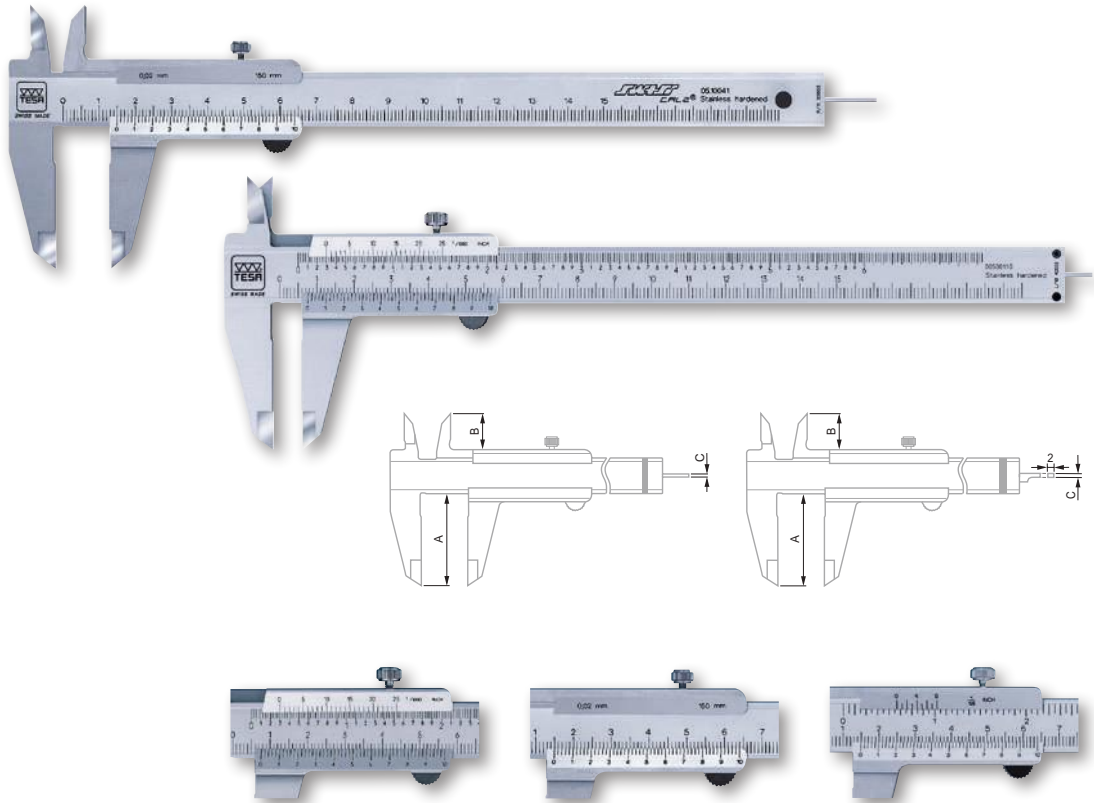

No	=							
		mm	in	mm	in	A mm	B mm	C mm
00510041	SWISSCAL 2	0 ÷ 150	–	0,02	–	40	15,5	Ø 1,5
00510047	Standard	0 ÷ 150	–	0,05	–	40	15,5	Ø 1,5
00530103	Standard	0 ÷ 150	0 ÷ 6	0,05	1/128	40	15,5	Ø 1,5
00530104	Standard	0 ÷ 200	0 ÷ 8	0,05	1/128	50	18	1,5 x 2
00530105	Standard	0 ÷ 300	0 ÷ 12	0,05	1/128	64	22	–
00530110	Standard	0 ÷ 150	0 ÷ 6	0,02	0.001	40	15,5	Ø 1,5
00530111	Standard	0 ÷ 200	0 ÷ 8	0,02	0.001	50	18	1,5 x 2
00530112	Standard	0 ÷ 300	0 ÷ 12	0,02	0.001	64	22	–
00530120	Self-locking model	0 ÷ 150	0 ÷ 6	0,05	1/128	40	15,5	1,5 x 2
00530121	Self-locking model	0 ÷ 150	0 ÷ 6	0,02	0.001	40	15,5	1,5 x 2
00530130	Self-locking model with parallax-free readout	0 ÷ 150	0 ÷ 6	0,05	1/128	40	15,5	1,5 x 2
00530131	Self-locking model with parallax-free readout	0 ÷ 150	0 ÷ 6	0,02	0.001	40	15,5	1,5 x 2

OPTIONAL ACCESSORIES:

00560013 Depth foot for calipers up to 150 mm

0051610365 Magnetic magnifying glass, 3x magnification



WORKSHOP DIGITAL CALIPERS

The range of IP67 calipers guarantees the highest level of protection against the penetration of dust and liquids. The TLC (TESA Link Connector) system built into all the TwinCal calipers provides the connection of these instruments to a PC for the easy acquisition of measurement data. The unique display housing, protected by a steel plate surrounded with a rubber seal guarantees durability and offers fine sensitivity during measurement.

TWIN-CAL IP67 – Models with Rounded Measuring Faces for Internal Dimensions

- Complete IP67 protection against the penetration of dust and liquids, even when the cable is connected.
- Unique TWIN connectivity concept allowing for upgrade across the range.

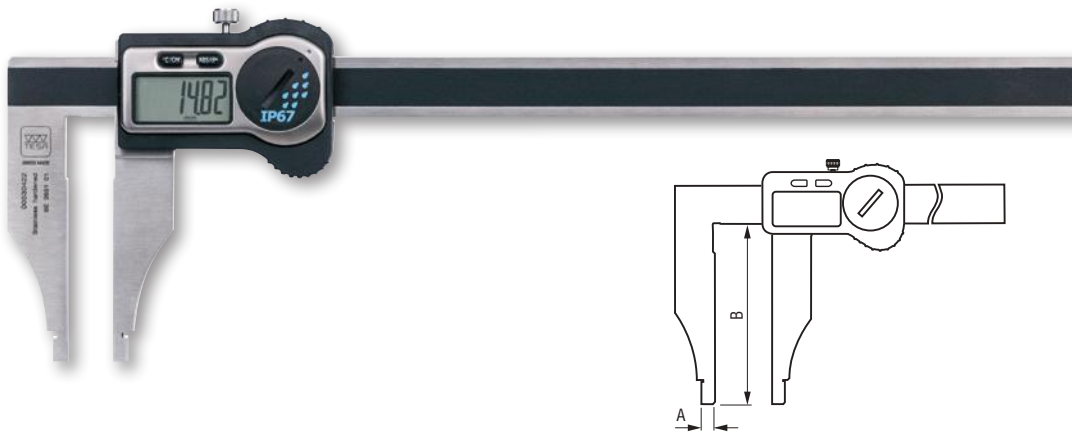

No	mm	in	A mm	B mm
00530421	200	8	5	80
00530422	250	10	5	80
00530423	300	12	5	90
00530424	500	20	10	150
00530425	600	24	10	150
00530426	800	32	10	150
00530427	1000	40	10	150

OPTIONAL ACCESSORIES:

01961000	Lithium battery, 3V, CR2032
04760180	TESA TLC-TWIN wireless emitter-receiver Compatible with any instrument fitted with a TLC – TESA Link Connector
04760181	TESA TLC-USB cable for instruments with a TLC connector
04760182	TLC-DIGIMATIC cable for instruments with a TLC connector

- ISO 13385-1
- 0,01 mm / 0.0005 in
- LCD, 11 mm
- Floating zero
- mm / in conversion
- L ≤ 100 mm: 20 µm
100 < L ≤ 600 mm: 30 µm
600 < L ≤ 1000 mm: 40 µm
- 10 µm
- Scale with incremental divisions, inductive
- 2,5 m/s
- TLC Connectivity
- Stainless steel
- 3V Lithium battery, CR2032
- 12.000 hours
- Standby mode after 10 minutes, instrument retains the zero position. Automatic shut off after 2 hours, instrument retains the zero in ABS mode, but the zero must be reset if the instrument is in DIFF mode.
- 10°C to 60°C
- 10°C to 40°C
- 100 %
- IP67
- 1907/2006/CE
2004/108/CE
2002/96/CE
- Plastic storage case
- Inspection report with declaration of conformity
- Serial number identification

TWIN-CAL IP67 – Models with Rounded Measuring Faces for Internal Dimensions and Knife-edge Jaws

- Complete IP67 protection against the penetration of dust and liquids, even when the cable is connected
- Unique TWIN connectivity concept allowing for upgrade across the range.

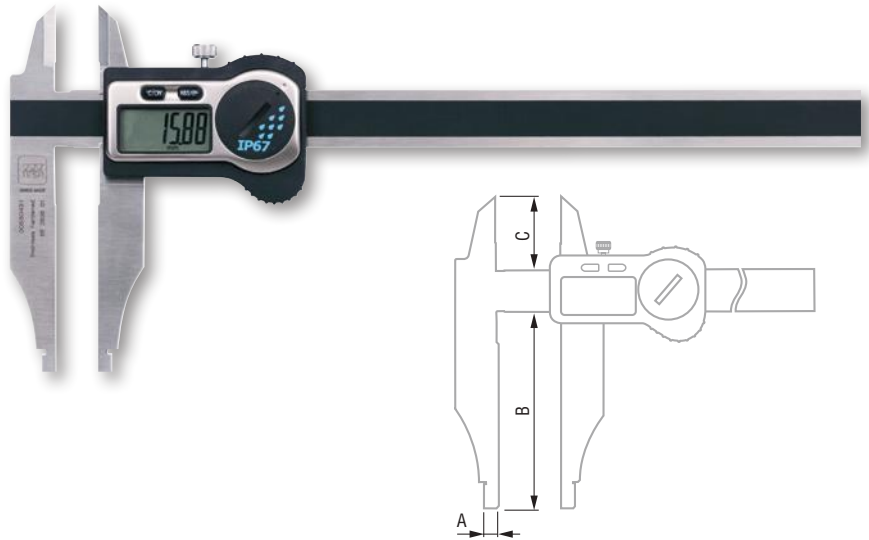

- ISO 13385-1
- 0,01 mm / 0.0005 in
- LCD, 11 mm
- Floating zero
- mm / in conversion
- L ≤ 100 mm: 20 μm
100 < L ≤ 600 mm: 30 μm
600 < L ≤ 1000 mm: 40 μm
- 10 μm
- Scale with incremental divisions, inductive
- 2,5 m/s
- TLC Connectivity
- Stainless steel
- 3V Lithium battery, CR2032
- 12.000 hours
- Standby mode after 10 minutes, instrument retains the zero position. Automatic shut off after 2 hours, instrument retains the zero in ABS mode, but the zero must be reset if the instrument is in DIFF mode.
- 10°C to 60°C
- 10°C to 40°C
- 100 %
- IP67
- 1907/2006/CE
2004/108/CE
2002/96/CE
- Plastic storage case
- Inspection report with declaration of conformity
- Serial number identification

No					
00530431	200	8	5	80	30
00530432	250	10	5	80	37
00530433	300	12	5	90	37
00530434	500	20	10	150	60
00530435	600	24	10	150	60
00530436	800	32	10	150	56
00530437	1000	40	10	150	56

OPTIONAL ACCESSORIES:

01961000	Lithium battery, 3V, CR2032
04760180	TESA TLC-TWIN wireless emitter-receiver Compatible with any instrument fitted with a TLC – TESA Link Connector
04760181	TESA TLC-USB cable for instruments with a TLC connector
04760182	TLC-DIGIMATIC cable for instruments with a TLC connector



TWIN-CAL IP67 – Models with Rounded Measuring Faces for Internal Dimensions and Knife-edge Jaws for External Dimensions

- Complete IP67 protection against the penetration of dust and liquids, even when the cable is connected
- Unique TWIN connectivity concept allowing for upgrade across the range.

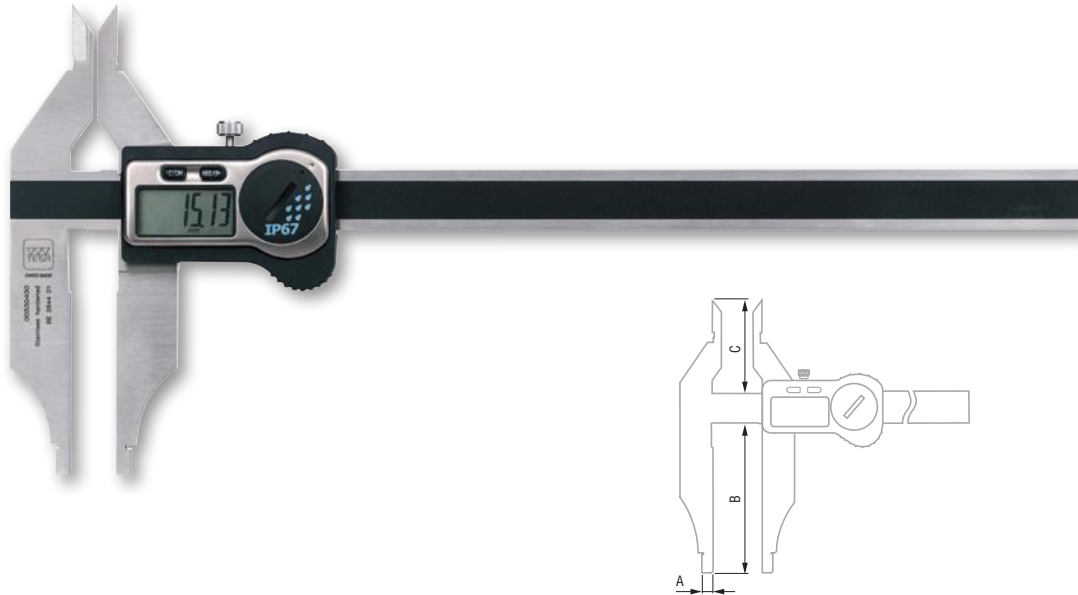

No	mm	in	A mm	B mm	C mm
00530430	250	10	5	80	54

OPTIONAL ACCESSORIES:

01961000	Lithium battery, 3V, CR2032
04760180	TESA TLC-TWIN wireless emitter-receiver Compatible with any instrument fitted with a TLC – TESA Link Connector
04760181	TESA TLC-USB cable for instruments with a TLC connector
04760182	TLC-DIGIMATIC cable for instruments with a TLC connector

- ISO 13385-1
- 0,01 mm / 0.0005 in
- LCD, 11 mm
- Floating zero
- mm / in conversion
- L ≤ 100 mm: 20 µm
100 < L ≤ 250 mm: 30 µm
- 10 µm
- Scale with incremental divisions, inductive
- 2,5 m/s
- TLC Connectivity
- Stainless steel
- 3V Lithium battery, CR2032
- 12.000 hours
- Standby mode after 10 minutes, instrument retains the zero position. Automatic shut off after 2 hours, instrument retains the zero in ABS mode, but the zero must be reset if the instrument is in DIFF mode.
- 10°C to 60°C
- 10°C to 40°C
- 100 %
- IP67
- 1907/2006/CE
2004/108/CE
2002/96/CE
- Plastic storage case
- Inspection report with declaration of conformity
- Serial number identification



DIN 862
(Style EN-2)
NFE 11-091



Maximum permissible errors in accordance with standard



Hardened stainless steel



Plastic or wooden storage case depending on the size of the model



Inspection report with a declaration of conformity



Serial number identification



Satin-chrome scale background; main scale set back slightly for protection against wear.

VERNIER CALIPERS

The simplest calipers to use with engraved scales for reading very fine divisions on measurements.

Models with Rounded Measuring Faces for Internal Dimensions (Without Fine Adjust Device)

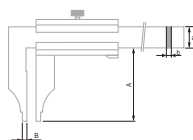
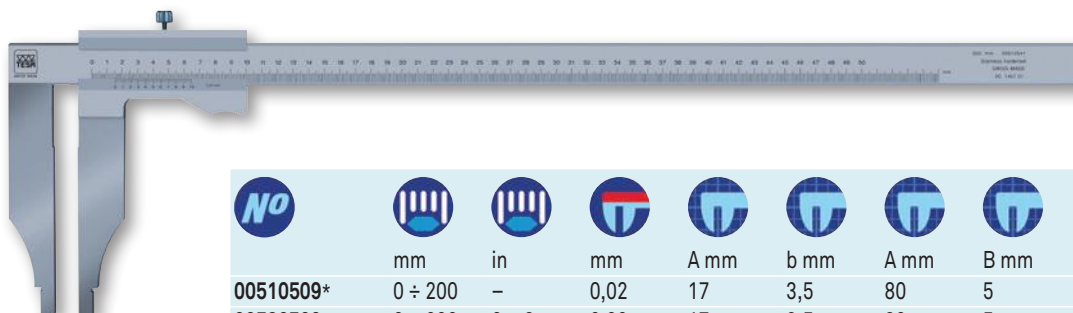

No							
	mm	in	mm	A mm	b mm	A mm	B mm
00510509*	0 ÷ 200	–	0,02	17	3,5	80	5
00530509	0 ÷ 200	0 ÷ 8	0,02	17	3,5	80	5
00510506	0 ÷ 200	–	0,05	17	3,5	80	5
00510511	0 ÷ 250	–	0,02	20	4	90	5
00510512	0 ÷ 250	–	0,05	20	4	90	5
00510521	0 ÷ 300	–	0,02	20	4	90	5
00530521	0 ÷ 300	0 ÷ 12	0,02	20	4	90	5
00510522	0 ÷ 300	–	0,05	20	4	90	5
00510531	0 ÷ 400	–	0,02	24,5	5	125	10
00530531	0 ÷ 400	0 ÷ 15	0,02	24,5	5	125	10
00510541	0 ÷ 500	–	0,02	28	6	150	10
00510542	0 ÷ 500	–	0,05	28	6	150	10
00510551	0 ÷ 600	–	0,02	28	6	150	10

OPTIONAL ACCESSORY:

0051610365 Magnetic magnifying glass, 3x magnification

* Supplied with a flexible stainless steel rule, 200 mm long, part code 0951750181



DIN 862
(Style EN-2F)
NFE 11-091



Maximum permissible errors in accordance with standard



Hardened stainless steel



Plastic or wooden storage case, depending on the model



Inspection report with a declaration of conformity



Serial number identification



Satin-chrome scale background; main scale set back slightly for protection against wear

Models with Rounded Measuring Faces (With Fine Adjust Device)

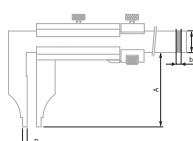
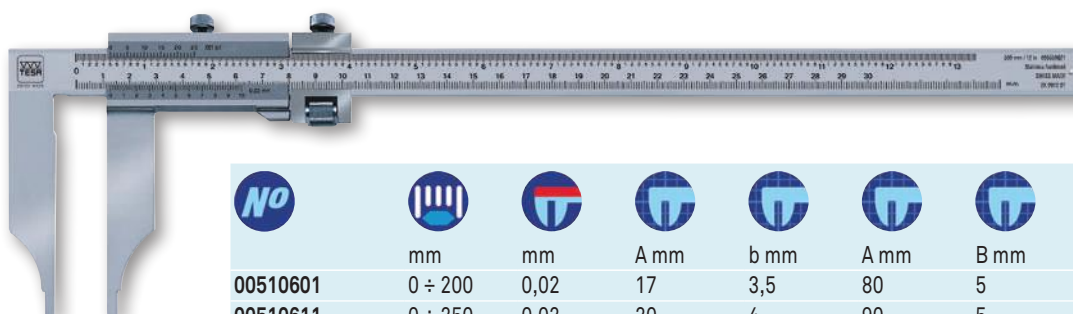

No						
	mm	mm	A mm	b mm	A mm	B mm
00510601	0 ÷ 200	0,02	17	3,5	80	5
00510611	0 ÷ 250	0,02	20	4	90	5
00510621	0 ÷ 300	0,02	20	4	90	5
00510641	0 ÷ 500	0,02	28	6	150	10
00510651	0 ÷ 600	0,02	28	6	150	10
00510661	0 ÷ 800	0,02	32	8	150	10
00510671	0 ÷ 1000	0,02	32	8	150	10
00510681	0 ÷ 1500	0,02	40	8	300	15
00510691	0 ÷ 2000	0,02	40	8	300	15

OPTIONAL ACCESSORY:

0051610365 Magnetic magnifying glass, 3x magnification



Models with Knife-edge Jaws for External Dimensions and Rounded Measuring Faces for Internal Dimensions (Without Fine Adjust Device)

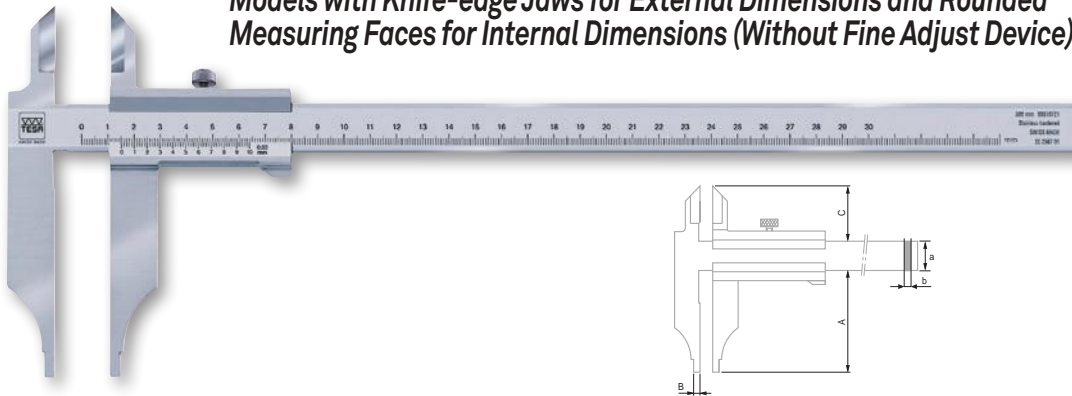

No	mm	in	mm	A mm	b mm	A mm	B mm	C mm
00510701	0 ÷ 200	–	0,02	17	3,5	80	5	30
00530701	0 ÷ 200	0 ÷ 8	0,02	17	3,5	80	5	30
00510711	0 ÷ 250	–	0,02	20	4	80	5	38
00510721	0 ÷ 300	–	0,02	20	4	90	5	38
00530721	0 ÷ 300	0 ÷ 12	0,02	20	4	90	5	38
00510722	0 ÷ 300	–	0,05	20	4	90	5	38
00510741	0 ÷ 500	–	0,02	28	6	150	10	60
00530741	0 ÷ 500	0 ÷ 20	0,02	28	6	150	10	60
00510751	0 ÷ 600	–	0,02	28	6	150	10	60

OPTIONAL ACCESSORY:

0051610365 Magnetic magnifying glass, 3x magnification

Models with Knife-edge Jaws for External Dimensions and Rounded Measuring Faces for Internal Dimensions (With Fine Adjust Device)

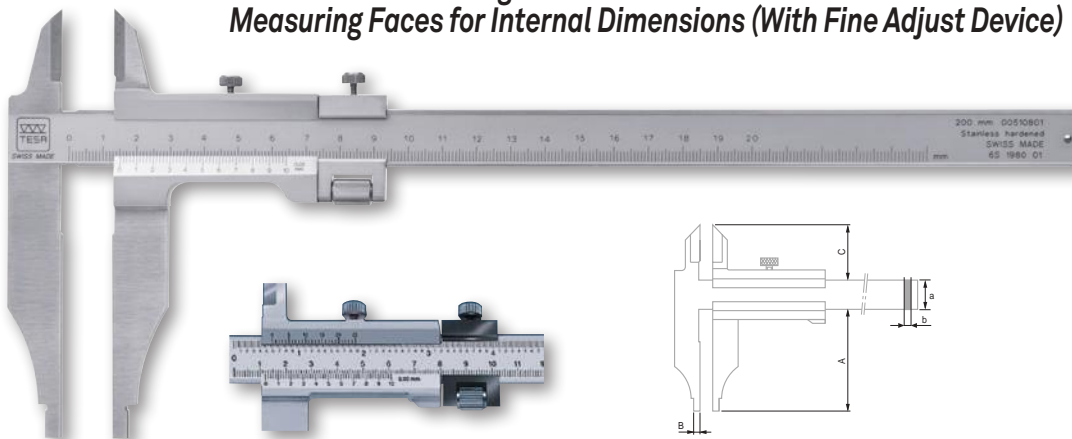

No	mm	in	mm	A mm	b mm	A mm	B mm	C mm
00510801	0 ÷ 200	–	0,02	17	3,5	80	5	30
00510821	0 ÷ 300	–	0,02	20	4	90	5	38
00530821	0 ÷ 300	0 ÷ 11	0,02	20	4	90	5	38
00510822	0 ÷ 300	–	0,05	20	4	90	5	38
00510841	0 ÷ 500	–	0,02	28	6	150	10	60
00530841	0 ÷ 500	0 ÷ 20	0,02	28	6	150	10	60
00510861	0 ÷ 800	–	0,02	32	8	150	10	56
00510871	0 ÷ 1000	–	0,02	32	8	150	10	56

OPTIONAL ACCESSORY:

0051610365 Magnetic magnifying glass, 3x magnification



DIN 862 (Style BN-2) NFE 11-091



Maximum permissible errors, in accordance with standard



Hardened stainless steel



Plastic or wooden storage case depending on size of the model



Inspection report with a declaration of conformity



Serial number identification



Satin-chrome scale background: main scale set back slightly for protection against wear



DIN 862 (Style BN-2) NFE 11-091



Maximum permissible errors in accordance with standard



Hardened stainless steel



Plastic or wooden storage case depending on size of the model



Inspection report with a declaration of conformity



Serial number identification



Satin-chrome scale background: main scale set back slightly for protection against wear

- +
- ISO 13385-1
- 0,01 mm / 0.0005 in
- LCD, 11 mm
- Floating zero
- mm / in conversion
- L ≤ 100 mm: 20 μm
100 < L ≤ 600 mm: 30 μm
600 < L ≤ 1000 mm: 40 μm
- 10 μm
- Scale with incremental divisions, inductive
- 2,5 m/s
- TLC Connectivity
- Stainless steel
- 3V lithium battery, CR2032
- 12.000 hours
- Standby mode after 10 minutes, instrument retains the zero position. Automatic shut off after 2 hours, instrument retains the zero in ABS mode, but the zero must be reset if the instrument is in DIFF mode.
- 10°C to 60°C
- 10°C to 40°C
- 100 %
- IP67
- 1907/2006/CE
2004/108/CE
2002/96/CE
- Plastic storage case
- Inspection report with declaration of conformity
- Serial number identification

DIGITAL DEPTH CALIPERS

The range of IP67 calipers guarantees the highest level of protection against the penetration of dust and liquids. The TLC (TESA Link Connector) system built into all the TWIN-CAL calipers provides the connection of these instruments to a PC for the easy acquisition of measurement data. The unique display housing, protected by a steel plate surrounded with a rubber seal guarantees durability and offers fine sensitivity during measurement.

TWIN-CAL IP67 – Models with Short Cut Measuring Face

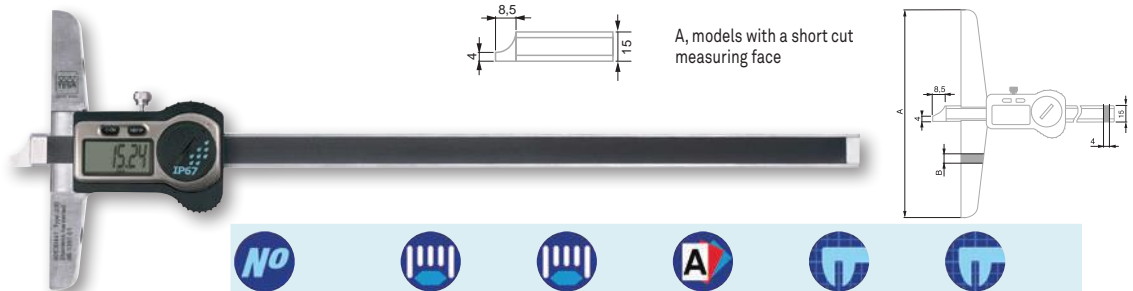

No			Models		
00530441	200	8	A	100	8
00530442	250	10	A	100	8
00530443	300	12	A	150	8
00530444	500	20	A	150	8

TWIN-CAL IP67 – Models with One Fixed Measuring Jaw

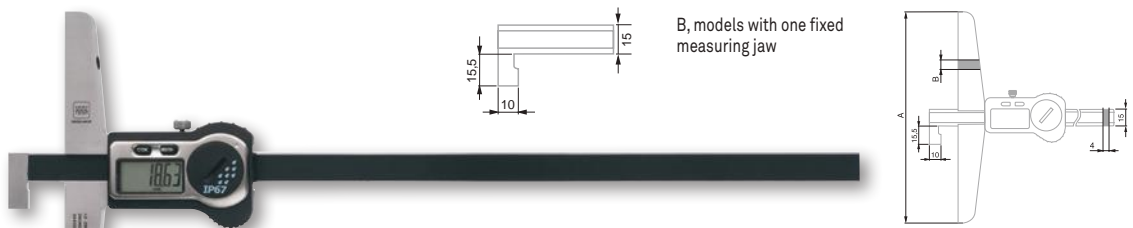

No			Models		
00530445	300	12	B	150	8
00530446	500	20	B	150	8

TWIN-CAL IP67 – Models with Two Fixed Measuring Jaws

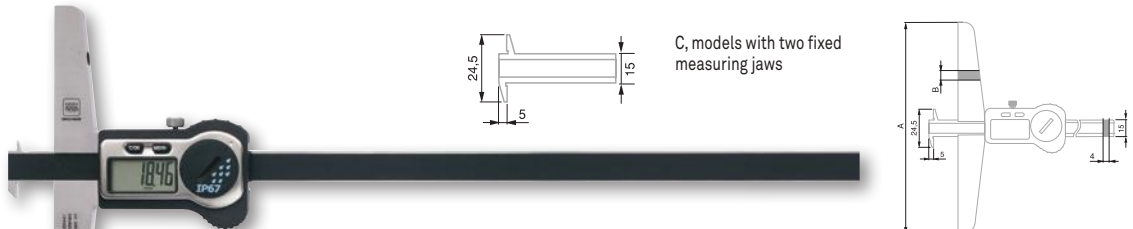

No			Models		
00530447	300	12	C	150	8



TWIN-CAL IP67 – Models with Rotary Stop Plate

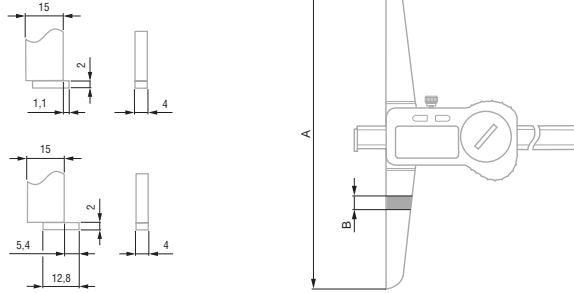
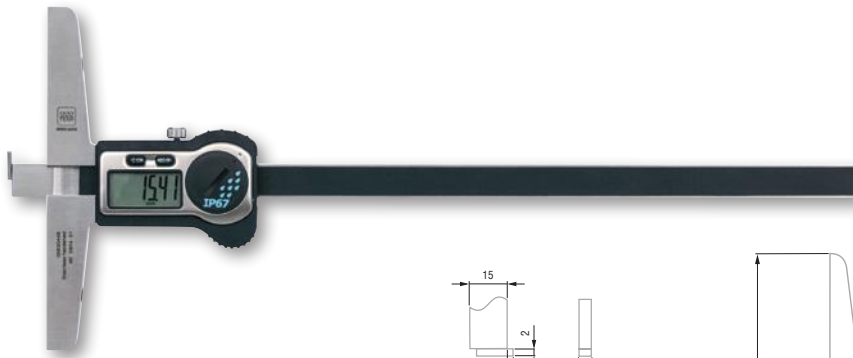

No	mm	in	A mm	B mm
00530448	250	10	100	8,5
00530449	350	14	100	8,5
00530450	500	20	150	8,5

OPTIONAL ACCESSORIES:

01961000	Lithium battery, 3V, CR2032
04760180	TESA TLC-TWIN wireless emitter-receiver Compatible with any instrument fitted with a TLC – TESA Link Connector
04760181	TESA TLC-USB cable for instruments with a TLC connector
04760182	TLC-DIGIMATIC cable for instruments with a TLC connector
00560103	Removable bridge 200 mm
00560104	Removable bridge 300 mm
00560105	Removable bridge 400 mm

TWIN-CAL IP67 – Small Sized Model with Steel Measuring Tip

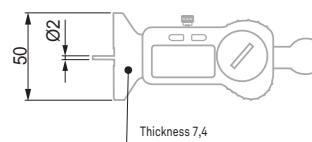

No	mm	in
00530451	25	1

OPTIONAL ACCESSORIES:

01961000	Lithium battery, 3V, CR2032
04760180	TESA TLC-TWIN wireless emitter-receiver Compatible with any instrument fitted with a TLC – TESA Link Connector
04760181	TESA TLC-USB cable for instruments with a TLC connector
04760182	TLC-DIGIMATIC cable for instruments with a TLC connector

- ISO 13385-1
- 0,01 mm / 0.0005 in
- LCD, 11 mm
- Floating zero
- Metric / in conversion
- L ≤ 100 mm: 20 µm
100 < L ≤ 600 mm: 30 µm
600 < L ≤ 1000 mm: 40 µm
- 10 µm
- Scale with incremental divisions, inductive
- 2,5 m/s
- TLC Connectivity
- Stainless steel
- 3V lithium battery, CR2032
- 12.000 hours
- Standby mode after 10 minutes, instrument retains the zero position. Automatic shut off after 2 hours, instrument retains the zero in ABS mode, but the zero must be reset if the instrument is in DIFF mode.
- 10°C to 60°C
- 10°C to 40°C
- 100 %
- IP67
- 1907/2006/CE
2004/108/CE
2002/96/CE
- Plastic storage box
- Inspection report with declaration of conformity
- Serial number identification



DIN 862
(Style C-2)
NFE 11-096

Maximum
permissible errors:
in accordance with
standard

Hardened stainless
steel

Plastic storage
case

Inspection report
with a declaration
of conformity

Serial number
identification

Satin-chrome scale
background; main
scale set back
slightly for protec-
tion against wear

VERNIER DEPTH CALIPERS

Depth calipers with:

- Flat measuring face – Steel tip – Rotary stop plate – Convertible models, short cut measuring face or steel tip– Convertible models, short cut measuring face or fixed hook



TESA Vernier Calipers with a Flat Measuring Face

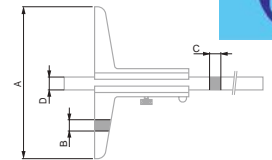

A, models with a flat measuring face

No	mm	Models	mm	A mm	B mm	C mm	D mm
00510133	0 ÷ 150	A	0,02	100	7,5	3	8
00510134	0 ÷ 150	A	0,05	100	7,5	3	8
00510143	0 ÷ 250	A	0,02	100	7,5	3	8
00510144	0 ÷ 250	A	0,05	100	7,5	3	8
00510163	0 ÷ 500	A	0,02	100	8,5	4	12
00510164	0 ÷ 500	A	0,05	100	8,5	4	12
00510173	0 ÷ 600	A	0,02	150	8,5	4	12



Calipers with Vernier Scale and Steel Measuring Tip

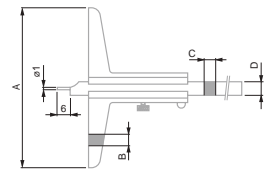

B, models with a steel measuring tip

No	mm	Models	mm	A mm	B mm	C mm	D mm
00510111	0 ÷ 80	B	0,02	50	7,5	3	8

* The removable bridges available as optional accessories are not suitable for this model

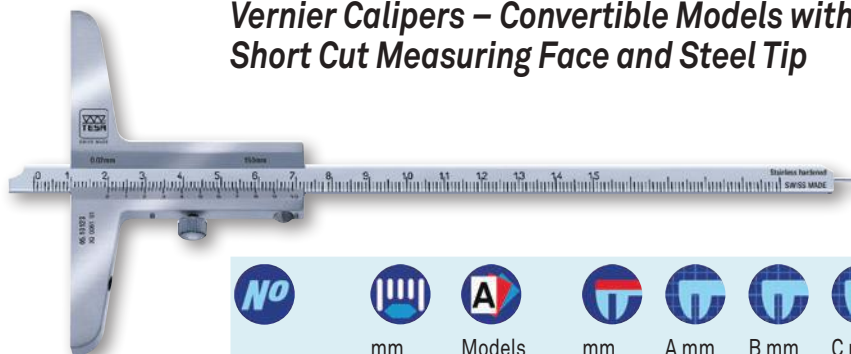

Vernier Calipers – Convertible Models with Short Cut Measuring Face and Steel Tip

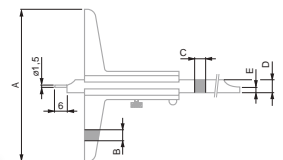

C, models with shortcut measuring face and steel tip

No	mm	Models	mm	A mm	B mm	C mm	D mm	E mm
00510123	0 ÷ 150	C	0,02	100	7,5	3	8	3,5
00510124	0 ÷ 150	C	0,05	100	7,5	3	8	3,5
00510125	0 ÷ 250	C	0,02	100	7,5	3	8	4
00510126	0 ÷ 250	C	0,05	100	7,5	3	8	4



Vernier Calipers with Rotary Stop Plate

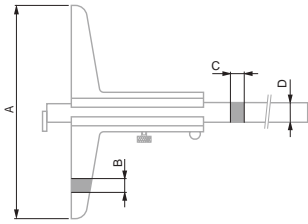
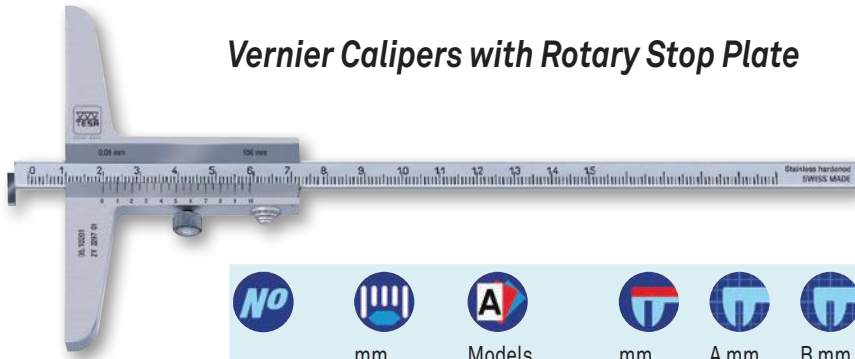

A, models with rotary stop plate

No	mm	Models	mm	A mm	B mm	C mm	D mm
00510201	0 ÷ 150	A	0,05	130	8,5	4	12
00510202	0 ÷ 150	A	0,02	130	8,5	4	12
00510211	0 ÷ 250	A	0,05	130	8,5	4	12
00510212	0 ÷ 250	A	0,02	130	8,5	4	12
00510222	0 ÷ 500	A	0,02	130	8,5	4	12

OPTIONAL ACCESSORIES:

0051610365	Magnetic magnifying glass, 3x magnification
00560103	Removable bridge 200 mm
00560104	Removable bridge 300 mm
00560105	Removable bridge 400 mm

Vernier Calipers – Convertible Models with Fixed Stop Plate and Short Cut Measuring Face

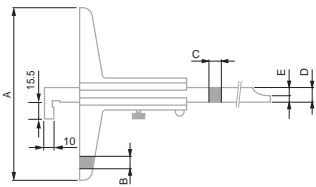

B, models with a fixed stop plate and a short cut measuring face

No	mm	Models	mm	A mm	B mm	C mm	D mm	E mm
00510175	0 ÷ 150	B	0,02	100	7,5	3	8	3,5
00510177	0 ÷ 250	B	0,02	130	8,5	4	12	4
00510179	0 ÷ 300	B	0,02	150	8,5	4	12	4
00510181	0 ÷ 500	B	0,02	150	8,5	4	12	4

OPTIONAL ACCESSORIES:

0051610365	Magnetic magnifying glass, 3x magnification
00560103	Removable bridge 200 mm
00560104	Removable bridge 300 mm
00560105	Removable bridge 400 mm

Removable Bridges



Each bridge is delivered with the appropriate fixing screws

No	mm	µm	mm	A mm	B mm	C mm
00560103	± 0,005	8	0,02	200	11,5	10
00560104	± 0,005	10	0,02	300	16	16
00560105	± 0,005	10	0,03	400	16	16

- DIN 862 (Style C-2) NFE 11-096
- Maximum permissible errors: in accordance with standard
- Hardened stainless steel
- Plastic storage case
- Inspection report with a declaration of conformity
- Serial number identification
- Satin-chrome scale background; main scale set back slightly for protection against wear

- DIN 862 (Style C-2) NFE 11-096
- Maximum permissible errors, in accordance with standard
- Hardened stainless steel
- Plastic storage case
- Inspection report with a declaration of conformity
- Serial number identification
- Satin-chrome scale background; main scale set back slightly for protection against wear

- Factory standard
- Packed suitable for shipment
- Inspection report with a declaration of conformity
- Serial number identification
- See table

- ISO 13385-1
- 0,01 mm / 0,0005 in
- LCD, 11 mm
- Floating zero
- mm / in conversion
- L ≤ 100 mm: 20 μm
100 < L ≤ 600 mm: 30 μm
600 < L ≤ 1000 mm: 40 μm
- 10 μm
- Scale with incremental divisions, inductive
- 2,5 m/s
- TLC Connectivity
- Stainless steel
- 3V Lithium battery, CR2032
- 12.000 hours
- Standby mode after 10 minutes, instrument retains the zero position. Automatic shut off after 2 hours, instrument retains the zero in ABS mode, but the zero must be reset if the instrument is in DIFF mode.
- 10°C to 60°C
- 10°C to 40°C
- 100 %
- IP67
- 1907/2006/CE
2004/108/CE
2002/96/CE
- Plastic storage box
- Inspection report with declaration of conformity
- Serial number identification

SCALE UNITS

The IP67 scale units assure the highest degree of protection against the penetration of dust and liquids. The integral TLC (TESA Link Connector) connectivity system common to the all the TWIN-CAL range allows the connection of all these instruments to a PC for easy data acquisition. The unique display module, protected by a steel plate surrounded by rubber seal guarantees optimal durability and sensitivity during measurement.

TWIN-CAL IP67 Horizontal Scale Unit

- Complete IP67 protection against the penetration of dust and liquids, even when the cable is connected
- Unique TWIN connectivity concept allowing for upgrade across the range

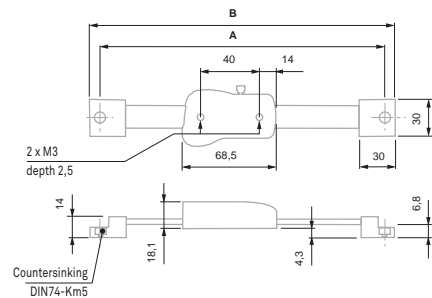

No				
00530471	150	6	265	278
00530473	300	12	415	428
00530474	600	24	725	738
00530475	1000	40	1135	1148

OPTIONAL ACCESSORIES:

01961000	Lithium battery, 3V, CR2032
04760180	TESA TLC-TWIN wireless emitter-receiver Compatible with any instrument fitted with a TLC – TESA Link Connector
04760181	TESA TLC-USB cable for instruments with a TLC connector
04760182	TLC-DIGIMATIC cable for instruments with a TLC connector



DIGITAL CALIPERS

For measurements up to 3000 mm.

INTERAPID Light

Measuring functions

- Zero setting
- Metric/Inch conversion
- Hold function for displayed value
- OPTO-RS data transfer, mono- and bi-directional
- Two adjustable points of origin (Ref I / Ref II)
- PRESET function
- MIN/MAX mode
- Two limit values for classification

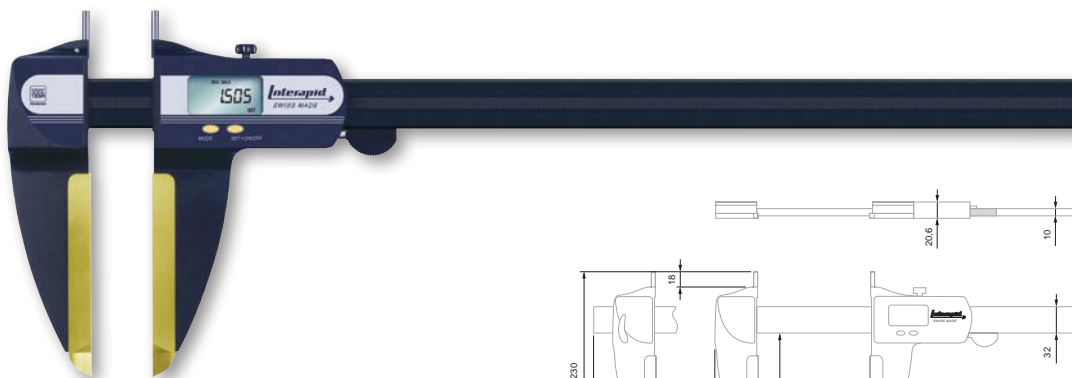

- DIN 862 and factory standard
- 0,01 mm / 0.0005 in
- LCD, 8,5 mm
- Floating zero
- mm / in conversion
- Scale with incremental divisions, inductive
- > 1,5 m/s
- Hardened steel jaws for external dimensions. Also with TiN coating, thickness to 7 mm. Tungsten carbide inserts for internal dimensions, 5 mm dia. Beam with light alloy hollow section, supported by hardened stainless steel rods.
- 3V lithium battery, CR2032
- ≈ 1,5 a (≈ 3300 h / a)
- 10°C to 60°C
- 5°C to 40°C
- IP40 (IEC 60529)
- EN 50081-1
EN 50082-1
- Packed suitable for shipping
- Inspection report for models up to 1500 mm
- Declaration of conformity
- Serial number identification
- Display lock
- RS232 Opto-coupled, mono- and bi-directional
- See table

No	A mm	μm	μm	B Fixed	C Mobile	kg
00590061	330	30	20	618	-	1,1
00590062	630	40	20	918	-	1,3
00590063	1025	60	20	-	1306	1,6
00590064	1525	150	20	-	1806	2
00590065	2040	250	30	-	2306	2,3
00590066	2545	350	30	-	2806	2,6
00590067	3050	450	40	-	3306	3

OPTIONAL ACCESSORIES:

01961000	Lithium battery, 3V, CR2032
00560095	Insert-holder, M2,5 thread
00560096	60° conical steel pin in hardened steel
00560097	Holder for dial gauge inserts L = 28 mm
00560098	Holder for dial gauge inserts L = 58 mm
00560099	Wooden case for INTERAPID Light 300 mm
00560100	Wooden case for INTERAPID Light 600 mm
00560101	Wooden case for INTERAPID Light 1000 mm
00560102	Wooden case for INTERAPID Light 1500 mm

Accessories for INTERAPID Light

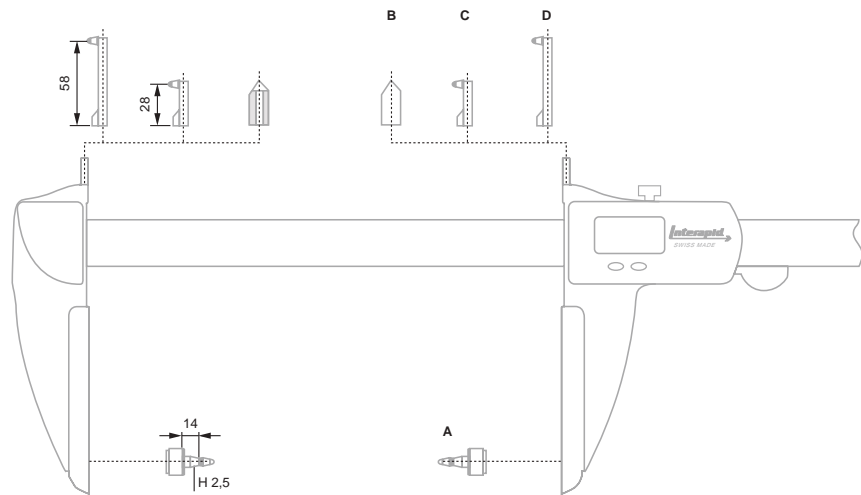

No	A	❄
00560095	Insert-holder, M2,5 thread for measuring inserts	A
00560096	60° conical steel pin in hardened steel for measuring centre distances >10 mm	B
00560097	Holder for dial gauge inserts used for groove measurement, L = 28 mm	C
00560098	Holder for dial gauge inserts used for groove measurement, L = 58 mm	D
00560099	Wooden case for INTERAPID Light 300 mm	
00560100	Wooden case for INTERAPID Light 600 mm	
00560101	Wooden case for INTERAPID Light 1000 mm	
00560102	Wooden case for INTERAPID Light 1500 mm	



CALIPERS WITH SPECIAL DESIGN

Calipers designated for specific measuring tasks including:

- Models with extra long jaws
- Models with hook jaws for measuring grooves
- Models for measuring throat depth

With Extra Long Jaws and Fine Adjust Device

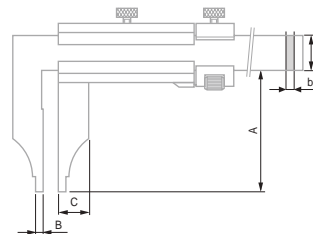
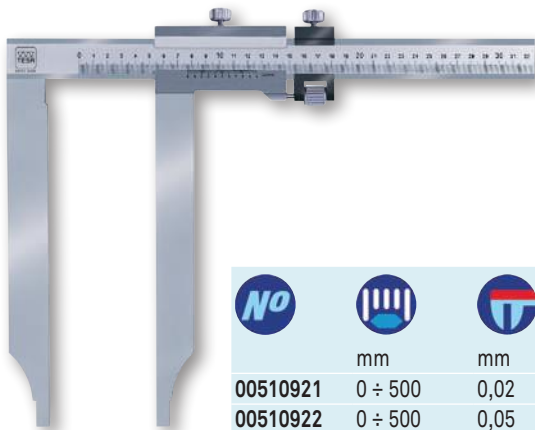

No	mm	mm	A mm	b mm	A mm	B mm	C mm
00510921	0 ÷ 500	0,02	28	6	250	10	30
00510922	0 ÷ 500	0,05	28	6	250	10	30
00510941	0 ÷ 1000	0,02	32	8	300	10	30
00510942	0 ÷ 1000	0,05	32	8	300	10	30

OPTIONAL ACCESSORY:

0051610365 Magnetic magnifying glass, 3x magnification

With Hook Jaws for External Dimensions

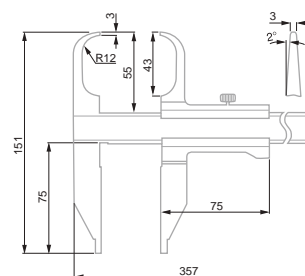
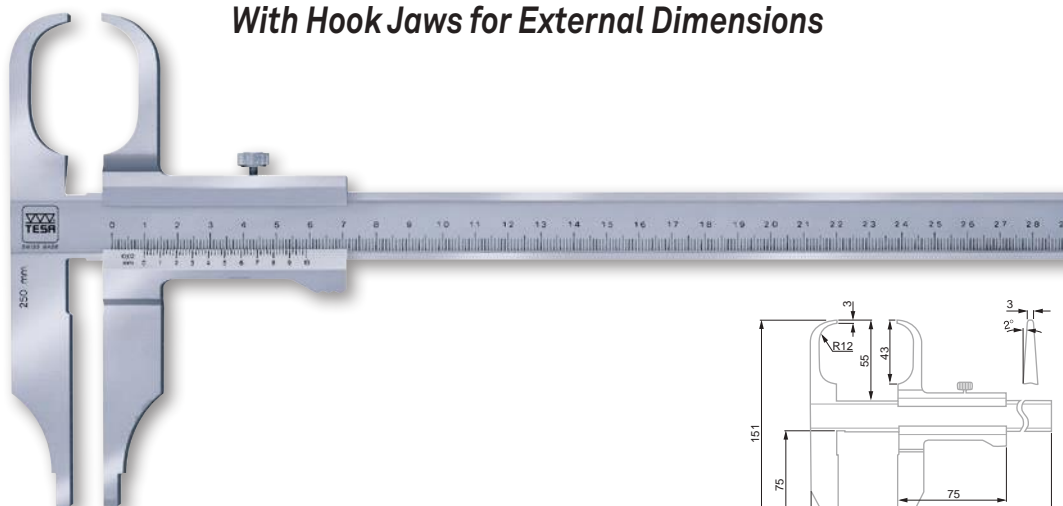

No	mm	mm
00510911	0 ÷ 250	0,02

OPTIONAL ACCESSORY:

0051610365 Magnetic magnifying glass, 3x magnification



Factory standard



Hardened stainless steel



Wooden storage case



Inspection report with a declaration of conformity



Serial number identification



Satin-chrome scale background; main scale set back slightly for protection against wear



NFE 11-096



Hardened stainless steel



Wooden storage case



Inspection report with declaration of conformity



Serial number identification



Satin-chrome scale background; main scale set back slightly for protection against wear

With Knife-edge Jaws for Internal Dimensions

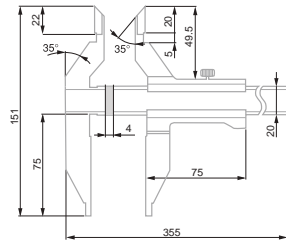
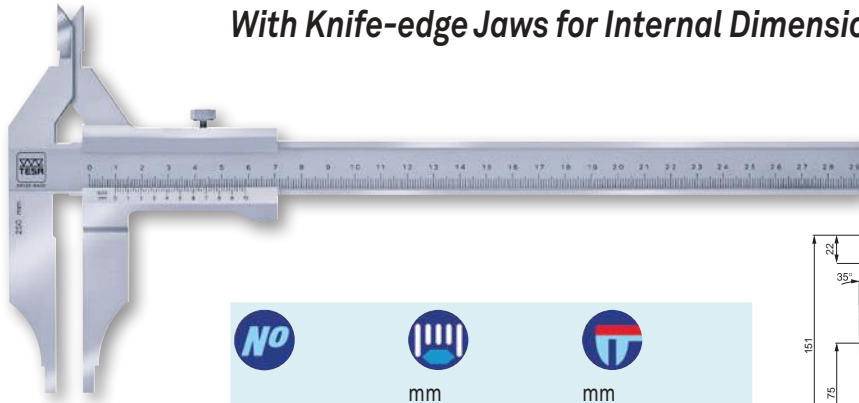

00510915	0 ÷ 250	0,02

- DIN 862 (Style DN-2) NFE 11-091
- Hardened stainless steel
- Plastic storage case
- Inspection report with a declaration of conformity
- Serial number identification
- Satin-chrome scale background; main scale set back slightly for protection against wear

With Vee Bridge

Made to measure groove and slot depths on cylindrical shafts.

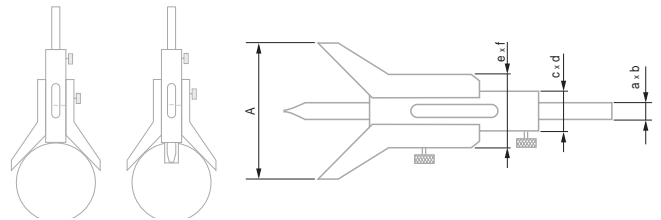
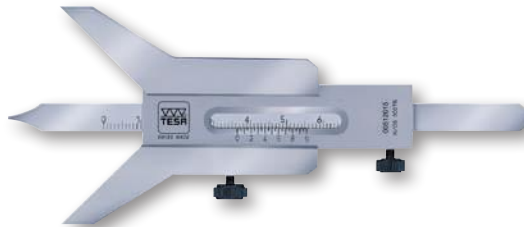

No									
00512015	5 ÷ 80	0,05	8	2	18	5	32	10	60
00512016	6 ÷ 120	0,05	8	2	18	5	34	10	90
00512017	7 ÷ 160	0,05	10	2	21,5	5	42	10	120

- NFE 11-096
- Hardened stainless steel
- Plastic storage case
- Inspection report with a declaration of conformity
- Serial number identification
- Satin-chrome scale background; main scale set back slightly for protection against wear

For Turned Grooves

Specially designed for measuring groove or slot diameters, e.g. on safety rings.

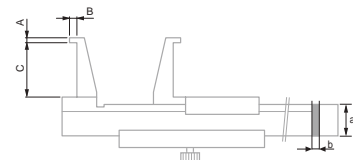
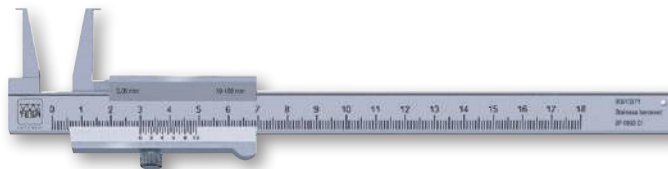

No							
00510371	10 ÷ 160	0,05	16	3	0,9	3	25
00510375	20 ÷ 160	0,05	16	3	2	5	40
00510383	26 ÷ 200	0,02	16	3	3	7	60
00510385	26 ÷ 200	0,05	16	3	3	7	60
00510387	30 ÷ 250	0,02	20	4	4	8,5	80
00510393	35 ÷ 300	0,02	20	4	5	10	100

- Factory standard
- Hardened stainless steel
- Plastic storage case
- Inspection report with a declaration of conformity
- Serial number identification
- Satin-chrome scale background; main scale set back slightly for protection against wear





External Micrometers

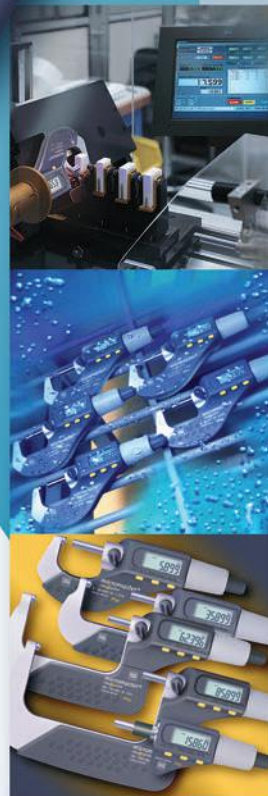

PRECISION MEASUREMENT





Precision measurement requires the use of micrometers. In 1848, the first measuring tool of this type was patented by the French inventor Jean Laurent Palmer as "calibre à vis et à vernier circulaire" (screw caliper with a circular vernier). Today, we continue to make external micrometers with these typical features. The introduction of the micrometer to the mechanical world came about due to the visit of the two American engineers, Joseph R. Brown and Lucian Sharpe to the Paris Exhibition in 1867. At that time, their attention was drawn to Palmer's invention, which greatly interested them. After some improvements of Palmer's design, the product was manufactured on a large scale and marketed successfully by the two partners. History repeated itself years later as TESA SA decided to manufacture external micrometers, making them the first products produced by the company.

Whether for internal or external measurement, TESA micrometers are distinguishable for their construction and quality. All our models respect the ABBE principle with the exception of the models with large measuring anvils for the measurement of gear teeth for example.



State of the art machining techniques are used for grinding the micrometer spindles, to ensure extreme accuracy and a true reproduction of the thread with negligible pitch deviations. For this reason we can guarantee a very low measuring uncertainty to our instrument users. TESA micrometers are designed to meet the most exacting demands. They are robust and ergonomically designed.

Max. permissible errors

			
Measuring range mm	Maximum permissible errors* μm	Number of interference fringes or rings	μm
0 ÷ 25	4	6	2
25 ÷ 50	4	6	2
50 ÷ 75	5	10	3
75 ÷ 100	5	10	3
100 ÷ 125	6		3
125 ÷ 150	6		3
150 ÷ 175	7		4
175 ÷ 200	7		4
200 ÷ 225	8		4
225 ÷ 250	8		4
250 ÷ 275	9		5
275 ÷ 300	9		5
300 ÷ 325	10		5
325 ÷ 350	10		5
350 ÷ 375	11		6
375 ÷ 400	11		6
400 ÷ 425	12		6
425 ÷ 450	12		6
450 ÷ 475	13		7
475 ÷ 500	13		7

* Including the errors of the measuring element as well as any deviations in the flatness and parallelism of the measuring faces, plus any errors due to the flexing of the frame.

























We offer an extensive range of micrometers, from a classic model through to micrometers for special applications, and also micrometer heads, complete sets, accessories and all items needed for calibration. They are available in analogue or digital versions, and also digital versions with results output.







TESA MICROMASTER Electronic Micrometers with Digital Display

With patented TESA CAPA μ SYSTEM.

- Measuring span of 30 mm.
- Large easy-to-read digital display.
- Models:
 - EASY IP40 with a single function key.
 - IP54 with water spray protection as well as IP54 RS with an RS232 interface.



-  +
-  DIN 863 T1
-  0,001 mm / 0,00005 in
-  LCD, digit height: 7 mm
-  Floating zero
-  Conversion mm/in
-  Tungsten carbide tipped
-  3V lithium battery
-  1 to 2 a (\approx 2000 h/a)
-  Automatic shut-down after 10 min. Display setting is maintained as long as power supply remains stable.
-  -10°C to 60°C
-  10°C to 40°C
-  80 %, noncondensing
-  Protection as per IEC 60529: IP40 (also valid with used RS data output) or IP54
-  CE
-  Plastic case
-  Measuring range 0 to 100: with SCS calibration certificate
-  Measuring range $>$ 100 mm : with inspection report and declaration of conformity
-  Identification number
-  Display lock (except for model EASY)
-  RS232 interface, opto-coupled
-  0,5 mm
-  Max. 10 N
-  \leq 100 mm: \varnothing 6,5 mm
 $>$ 100 mm: \varnothing 8 mm



No	 mm	 mm	 in	 in	 IP40	 IP54
06030010	0 \div 30	0 \div 30	0 \div 1.2	0 \div 1.2	IP40	-
06030020	0 \div 30	0 \div 30	0 \div 1.2	0 \div 1.2	IP54	-
06030021	25 \div 50	23 \div 53	1 \div 2	0.9 \div 2.1	IP54	-
06030022	50 \div 75	48 \div 78	2 \div 3	1.9 \div 3.1	IP54	-
06030023	75 \div 100	74 \div 104	3 \div 4	2.9 \div 4.1	IP54	-
06030030	0 \div 30	0 \div 30	0 \div 1.2	0 \div 1.2	IP54	RS232
06030031	25 \div 50	23 \div 53	1 \div 2	0.9 \div 2.1	IP54	RS232
06030032	50 \div 75	48 \div 78	2 \div 3	1.9 \div 3.1	IP54	RS232
06030033	75 \div 100	74 \div 104	3 \div 4	2.9 \div 4.1	IP54	RS232
06030071	100 \div 125	98 \div 127	4 \div 5	3.9 \div 5.01	IP54	RS232
06030072	125 \div 150	123 \div 152	5 \div 6	4.9 \div 6.01	IP54	RS232
06030073	150 \div 175	149 \div 178	6 \div 7	5.9 \div 7.01	IP54	RS232
06030074	175 \div 200	174 \div 203	7 \div 8	6.9 \div 8.01	IP54	RS232
06030075	200 \div 225	199 \div 229	8 \div 9	7.9 \div 9.01	IP54	RS232
06030076	225 \div 250	224 \div 254	9 \div 10	8.9 \div 10.01	IP54	RS232
06030077	250 \div 275	250 \div 279	10 \div 11	9.9 \div 11.01	IP54	RS232
06030078	275 \div 300	275 \div 304	11 \div 12	10.9 \div 12.01	IP54	RS232

OPTIONAL ACCESSORIES:

01961000	Lithium battery, 3V, CR2032
00160201	TESA micrometer stand with clamp aperture 16 mm
072110123	ETALON micrometer stand with clamp aperture 20 mm
04761062	Opto-USB cable, duplex, bidirectional communication

MICROMASTER IP54 SET

Set consisting of 3 Micromaster external micrometers covering 0 \div 75 mm measuring range.

No	 =	
06030029	Set of 3 MICROMASTER IP54 with RS232 output	0 \div 75



CONSISTING OF:

- 06030030 MICROMASTER RS IP54 digital micrometer, 0 \div 30 mm, 0,001 mm resolution, IP54 rating and RS232 output.
- 06030031 MICROMASTER RS IP54 digital micrometer, 25 \div 50 mm, 0,001 mm resolution, IP54 rating and RS232 output.
- 06030032 MICROMASTER RS IP54 digital micrometer, 50 \div 75 mm, 0,001 mm resolution, IP54 rating and RS232 output.
- 02119021 Etalon setting standard, 50 mm



TESAMASTER High Precision Micrometers with Digital Counter Reading to 0,1 mm

Analogue indication of full millimetres, hundredths and fractions of hundredths. Accurate, parallax-free reading on the vernier down to 0,001 mm.

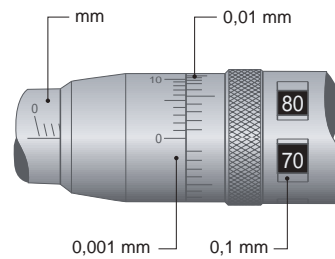

- DIN 863 T1
NFE 11-095
- Scale
division: 0,1 mm
or 0.005 in
- Tungsten carbide
- Plastic case
- Measuring range
0 to 100 mm
with inspection
report and declara-
tion of conformity
- Measuring range
> 100 mm with
a declaration of
conformity
- Identification
number
- 0,5 mm
- Max. 10 N
- ≤ 100 mm: Ø 6,5 mm
> 100 mm: Ø 8 mm
- Vernier reading
to 0,001 mm
or 0.0001 in

No	mm	µm	µm
00310001	0 ÷ 25	2	1
00310002	25 ÷ 50	2	1,5
00310003	50 ÷ 75	3	1,5
00310004	75 ÷ 100	3	1,5
00310005	100 ÷ 125	4	2
00310006	125 ÷ 150	4	2,5
00310007	150 ÷ 175	5	3
00310008	175 ÷ 200	5	3
00310009	200 ÷ 225	6	3,5
00310010	225 ÷ 250	6	3,5

- DIN 863 T1
NFE 11-095
- Tungsten carbide tipped
- Plastic case
- Inspection report with a declaration of conformity
- Identification number
- 1 mm
- Max. 10 N
- Ø 6,5 mm
- Parallax-free vernier reading to 0,001 mm

ETALON MICRORAPID 226 with 1 mm Revolution

High precision micrometers – Fast, accurate reading – No reading error of the millimetre fractions – Barrel with scale to 1 mm – Thimble with 100 graduations and vernier reading to 0,001 mm.

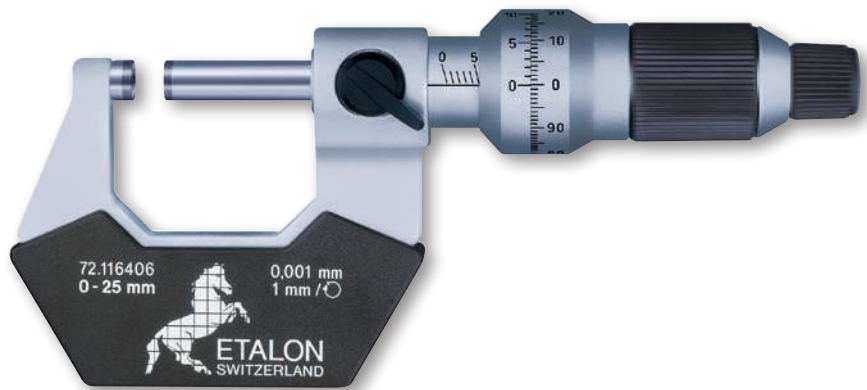

No				
	mm	µm		µm
072116406	0 ÷ 25	2		1
072116407	25 ÷ 50	2		1,5
072116408	50 ÷ 75	3		1,5
072116409	75 ÷ 100	3		1,5

- DIN 863 T1
NFE 11-095
- Tungsten carbide tipped
- Plastic case
- Measuring range 0 to 100 mm with inspection report and declaration of conformity
- Measuring range > 100 mm with a declaration of conformity
- Identification number
- 0,5 mm
- Max. 10 N
- ≤ 100 mm: Ø 6,5 mm,
> 100 ≤ 200 mm: Ø 8 mm
- 0 to 100 mm

ETALON 260 Standard Models with Analogue Indication

The knurled sleeve only needs to be reversed to render the friction drive built into the thimble inactive.



No					
	mm	mm	µm		µm
071115887	0 ÷ 25	0,002	2		2
071115888	25 ÷ 50	0,002	2		2
071115889	50 ÷ 75	0,002	3		3
071115890	75 ÷ 100	0,002	3		3
071115891	100 ÷ 125	0,01	4		3
071115892	125 ÷ 150	0,01	4		3
071115893	150 ÷ 175	0,01	5		4
071115894	175 ÷ 200	0,01	5		4



TESA ISOMASTER Standard Models with Analogue Indication

Slanted full millimetres on the barrel are set apart from the straight half millimetres to virtually eliminate reading errors.

The knurled sleeve needs only to be reversed to render the friction drive built into the thimble inactive.



No	mm	mm
00110101	0 ÷ 25	0,01
00110102	25 ÷ 50	0,01
00110103	50 ÷ 75	0,01
00110104	75 ÷ 100	0,01
00110105	100 ÷ 125	0,01
00110106	125 ÷ 150	0,01
00110107	150 ÷ 175	0,01
00110108	175 ÷ 200	0,01
00110109	200 ÷ 225	0,01
00110110	225 ÷ 250	0,01
00110111	250 ÷ 275	0,01
00110112	275 ÷ 300	0,01

- DIN 863 T1 NFE 11-095
- Tungsten carbide tipped
- Plastic case
- Measuring range 0 to 100 mm with inspection report and declaration of conformity
- Measuring range smaller than 100 mm with a declaration of conformity
- Identification number
- 0.5 mm
- Max. 10 N
- ≤ 100 mm: Ø 6,5 mm
> 100 ≤ 300 mm: Ø 8 mm

Set of 4 TESA ISOMASTER Micrometers

The models covering application range 0 to 100 mm provide the quality that you need at competitive prices.



No	=	mm
00110113	Set of 4 ISOMASTER micrometers	0 ÷ 100
CONSISTING OF:		
00110101	ISOMASTER AA external micrometer with vernier scale, 0 ÷ 25 mm and resolution to 0,01 mm	
00110102	ISOMASTER AA external micrometer with vernier scale, 25 ÷ 50 mm and resolution to 0,01 mm	
00110103	ISOMASTER AA external micrometer with vernier scale, 50 ÷ 75 mm and resolution to 0,01 mm	
00110104	ISOMASTER AA external micrometer with vernier scale, 75 ÷ 100 mm and resolution to 0,01 mm	

-
- Plastic case



N DIN 863 T1
NFE 11-095

Tungsten carbide tipped

Plastic case

Inspection report with a declaration of conformity

No Identification number

0,5 mm

Max. 10 N

Ø 6,5 mm

0,01 mm

ETALON Basic to 0,01 mm

Standard micrometer with measuring range from 0 to 100 mm



No	mm
00119046	0 ÷ 25
00119047	25 ÷ 50
00119048	50 ÷ 75
00119049	75 ÷ 100



N DIN 863 T1
NFE 11-095

Tungsten carbide tipped

Plastic case

Inspection report with a declaration of conformity

No Identification number

0,5 mm

Max. 10 N

Ø 6,5 mm

0,01 mm

Set of 4 ETALON Basic Micrometers 0,01 mm Reading



No		mm
00119050	Set of 4 ETALON micrometers	0 ÷ 100
CONSISTING OF:		
00119046	ETALON micrometer with measuring range	0 ÷ 25 mm
00119047	ETALON micrometer with measuring range	25 ÷ 50 mm
00119048	ETALON micrometer with measuring range	50 ÷ 75 mm
00119049	ETALON micrometer with measuring range	75 ÷ 100 mm



MICRO-ETALON 225 - Precision Micrometers with a Dial Indicator

Feature a mobile anvil along with a built-in dial indicator. Ideal for comparative measurements on small part series. The nominal dimension is set on the micrometer while deviations are read on the dial indicator. Retractable anvil by means of a push-button. Rotating dial for fine adjustment, also with adjustable tolerance markers.

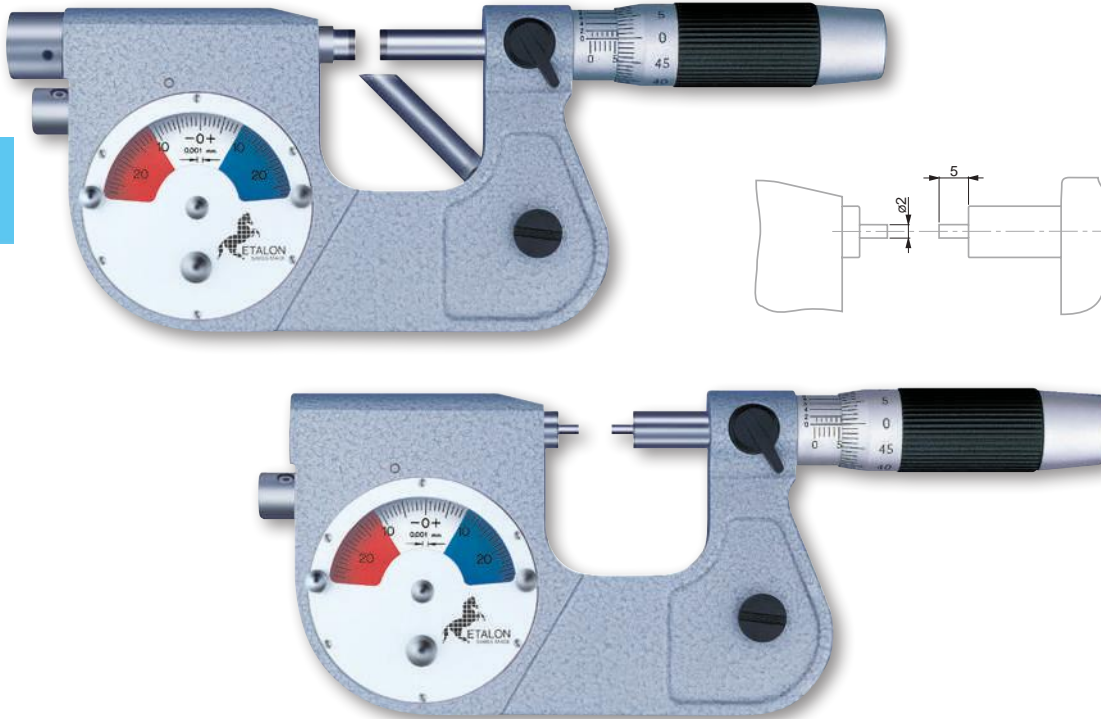

- DIN 863 T3 (Style D13)
- Micrometer: max. perm. error of 2 µm. Dial indicator: 1 µm.
- Dial indicator: repeatability limit of 0.5 µm
- Tungsten carbide tipped
- Plastic case
- Declaration of conformity
- 0,5 mm
- Anvil: 4,5 to 5,5 N
- 6,5 mm dia. Model with small measuring faces: 2 mm dia., 5 mm long
- Micrometer with vernier reading to 0,002 mm. Dial indicator: 0,001 mm.
- Dial indicator: ± 0,025 mm

	mm	
072108669	0 ÷ 25	Standard inserts
072108691	25 ÷ 50	Standard inserts
072108722	0 ÷ 20	Pointed inserts
OPTIONAL ACCESSORY:		
072110978	Protective cover for dial indicator	

Protective Cover for Micro-Etalon 225

Made in transparent plastic – Can be mounted on the bezel – Protects the indicator against dust particles and liquids – Prevents both tolerance markers from being accidentally displaced.



072110978	Protective cover for dial indicator



DIN 863 T3
(Style D14)
NFE 11-090

Meas. element:
max. perm. error
of 2 µm

Mobile anvil:
repeatability
limit of
0,5 µm.

Tungsten carbide
tipped

Adjustable part
support (except
model with small
measuring faces).

Plastic case

Declaration
of conformity

0,5 mm

Anvil:
2 up to 8 N,
adjustable

6,5 mm or 2 mm dia.
and length of 5 mm
for models
with small
measuring faces.

Vernier reading
to 0,002 mm

ETALON MICROSEL 280

These micrometers have a mobile anvil along with an 8 mm diameter clamping bore for mounting a sensor with linear action such as a TESA GT 21/22 electronic probe. Specially designed for batch inspection of small precision made parts.

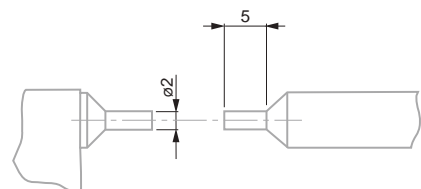
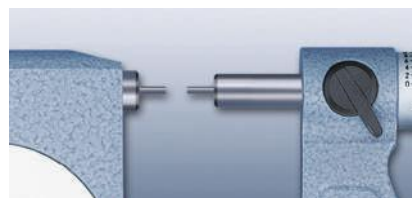
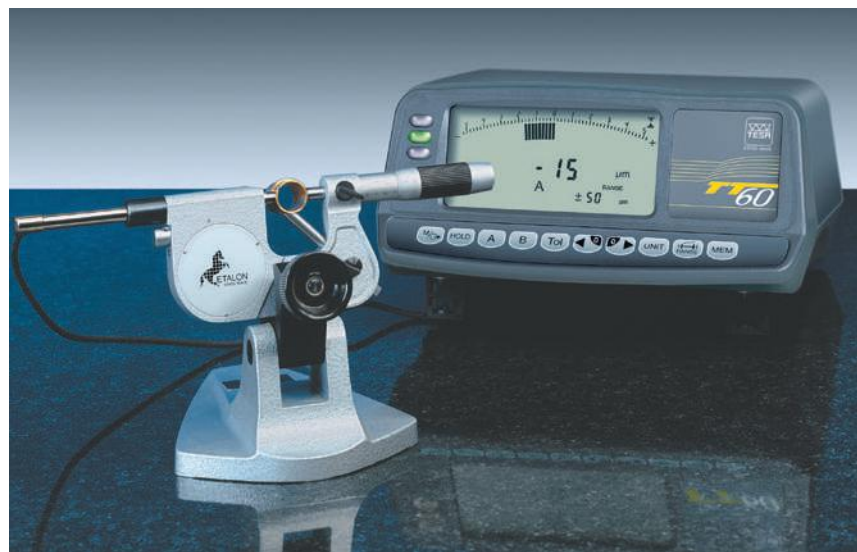

mm

072110816 0 ÷ 25 Standard inserts

072110853 0 ÷ 20 Pointed inserts

Electronic probe and micrometer stand are not part of the delivery scope and must be ordered separately.



MICROMASTER Micrometers with Small Measuring Faces

For measuring grooves, feather grooves, splines and other difficult to reach locations – Small measuring faces specially made to check small precision workpieces.



No	Measuring faces	
	mm	in
06030034	0 ÷ 30	0 ÷ 1.2
06030035	30 ÷ 60	1.2 ÷ 2.3

OPTIONAL ACCESSORY:
01961000 Lithium battery 3V, CR2032

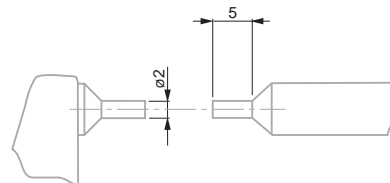

- TESA
- DIN 863 T3 (Style D3)
- 0,001 mm / 0.00005 in
- Conversion mm/in
- Fixed measuring faces: tungsten carbide.
- Degree of protection (IEC 60529): IP54 or IP40 with use of the digital output
- Plastic case
- SCS Measuring range 0 to 100: with a SCS calibration certificate.
- Identification number
- RS232 interface, opto-coupled.
- For additional technical data: see standard.
- Max. 10 N

TESAMASTER AD Micrometers with Small Measuring Faces



No	Measuring faces
	mm
00311301	0 ÷ 25

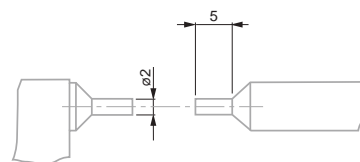

- TESA
- DIN 863 T3 (Style D3) NFE 11-090
- Scale division 0,1 mm
- Fixed measuring faces: tungsten carbide
- Plastic case
- Inspection report with a declaration of conformity
- Identification number
- Max. 10 N
- Vernier reading to 0,001 mm

MICRORAPID Micrometers with Small Measuring Faces

- DIN 863 T3 (Style D3) NFE 11-090
- Fixed measuring faces: tungsten carbide
- Plastic case
- Inspection report with a declaration of conformity
- Identification number
- 1 mm
- Max. 10 N
- 0,001 mm. Parallax-free reading on vernier



072116410	mm 0 ÷ 20

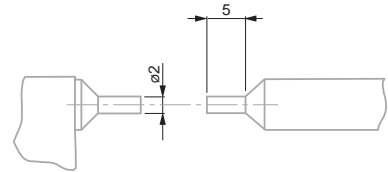

- DIN 863 T3 (Style D3) NFE 11-090
- Fixed measuring faces: tungsten carbide
- Plastic case
- Inspection report with a declaration of conformity
- Identification number
- Max. 10 N
- 0,01 mm

ISOMASTER AD Micrometers with Small Measuring Faces



00210101 00210102	mm 0 ÷ 25 25 ÷ 50

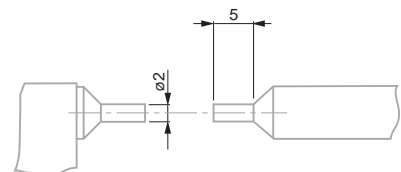

MICROMASTER Micrometers with Two Spherical Measuring Faces

Rounded measuring faces on both anvil and spindle for measuring concave surfaces on components, e.g. ball-bearing guides or wall thickness.



No	mm	in
06030081	0 ÷ 25	0 ÷ 1
06030082	20 ÷ 50	0.8 ÷ 1.9
06030083	45 ÷ 75	1.8 ÷ 2.9
06030084	70 ÷ 100	2.8 ÷ 3.9

MICROMASTER Micrometers with One Spherical Measuring Face

For the measurement of wall thickness of tubing and other similar tasks.



No	mm	in
06030079	0 ÷ 30	0 ÷ 1.2
06030080	25 ÷ 50	1 ÷ 2

- DIN 863 T3 (Style D1)
- 0,001 mm / 0.00005 in
- Tungsten carbide
- Plastic case
- Inspection report with a declaration of conformity
- Identification number
- RS232
- Additional technical data: see standard.
- Max. 10 N
- Spherical: 3,5 mm radius.

- DIN 863 T3 (Style D1)
- 0,001 mm or 0.00005 in
- Anvil in tungsten carbide. Micrometric spindle in tungsten carbide
- Plastic case
- Inspection report with a declaration of conformity
- Identification number
- RS232
- Other technical data see standard.
- Max. 10 N
- Anvil with a 3,5 mm spherical face (MICROMASTER) or 3,25 mm (ETALON). Spindle with a flat measuring face.

ETALON Micrometers with One Spherical Measuring Face



071115940	mm 0 ÷ 25

- DIN 863 T3 (Style D1)
- Anvil with TIC coating, Tungsten carbide spindle
- Plastic case
- Inspection report with a declaration of conformity
- Identification number
- Other technical data on MICROMASTER: see appropriate standard.
- Max. 10 N
- Anvil with 3,25 mm spherical measuring face. Spindle with a flat measuring face
- 0,002 mm



Spherical Element for External Micrometers

Holder with a ball tip to fit measuring faces \varnothing 6,5 mm – Used to measure tubing wall thickness or components with concave surfaces etc.

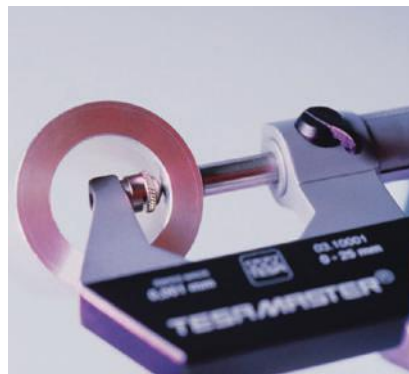

072103522	mm 5

- Steel ball tip, hardened and lapped. Dull-chrome brass retainer



MICROMASTER Micrometers for Soft Materials

With two large, round-edge measuring faces – Measure the thickness of materials such as paper and plastic sheets, felt, cloth and other soft materials. Non-rotating measuring spindle – without spindle lock.



No		
06030085	0 ÷ 30	0 ÷ 1.2

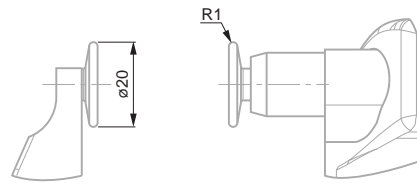

- +
- DIN 863 T3 (Style D6)
- 0,001 mm / 0.00005 in
- Conversion mm/in
- Max. permissible error: 4 µm
- Hardened steel
- Plastic case
- Inspection report with a declaration of conformity
- Identification number
- RS232
- Additional technical data: see standard.
- Max. 10 N
- Non-rotating, 20 mm diameter.
- Flatness tolerance: 3 µm
- Tolerance in Parallelism: 6 µm

ISOMASTER AF Micrometers for Soft Materials



No	
00210301	0 ÷ 25

- +
- DIN 863 T3 (Style D6)
- Hardened steel
- Plastic case
- Inspection report with a declaration of conformity
- Identification number
- Max. 10 N
- Ø 15 mm
- 0,01 mm
- Flatness tolerance: 3 µm
- Tolerance in parallelism: 6 µm

- DIN 863 T3 (Style D7)
- 0,001 mm / 0.00005 in
- Conversion mm/in
- Hardened steel
- Suitable from module 0,5 onwards
- Plastic case
- Inspection report with a declaration of conformity
- Identification number
- RS232
- Additional technical data: see standard.
- Max. 10 N
- Non-rotating spindle
≤ 85 mm: 25 mm dia.
> 85 ≤ 115 mm: 30 mm dia.

MICROMASTER Micrometers for Gear Pitch Measurement

Flanges with ring-shaped measuring faces for root tangent lengths, W_k on gear pitches, distance between grooves and slots as well as other hard-to-reach locations.

Non-rotating measuring spindle, without spindle lock.

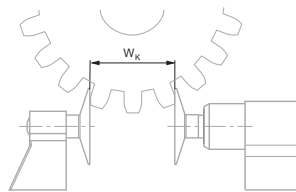

No	mm	in
06030041	0 ÷ 30	0 ÷ 1.2
06030042	25 ÷ 55	1 ÷ 2.1
06030043	55 ÷ 85	2.1 ÷ 3.35
06030044	85 ÷ 115	3.35 ÷ 4.5

- DIN 863 T3 (Style D7) NFE 11-090
- Hardened steel
- Suitable from module 0,6
- Plastic case
- Inspection report with a declaration of conformity
- Identification number
- Max. 10 N
- ≤ 100 mm: 25 mm dia.
> 100 ≤ 150 mm: 32 mm dia.
- 0,01 mm

ISOMASTER AE Micrometers for Gear Tooth / Pitch Measurement

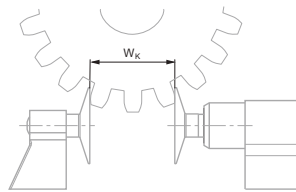

No	mm
00210201	0 ÷ 25
00210202	25 ÷ 50
00210203	50 ÷ 75
00210204	75 ÷ 100
00210205	100 ÷ 125
00210206	125 ÷ 150

Resolution		Accuracy		Flatness	Parallelism	Maximum flexure of the frame
mm	µm	Maximum permissible error disregarding a rim of 1 mm during inspection of the measuring faces and having partial contact with the measuring face.		µm	µm	µm
0 ÷ 30	10	Maximum permissible error with full contact of the measuring face (DIN863-T1)		2	5	2
25 ÷ 55	10	µm	µm	µm	µm	µm
55 ÷ 85	11	4	4	2	5	2
85 ÷ 115	12	5	5	2	5	3
				2	6	4



MICROMASTER with 7 Pairs of Interchangeable Measuring Inserts

Non-rotating spindle, without spindle lock.



No	mm	in
06030045	0 ÷ 30	0 ÷ 1.2
CONSISTING OF:		
06030099	MICROMASTER single micrometer for use with interchangeable measuring inserts, 0-30 mm	
00269027	Full set of 7 pairs of inserts	

- 0,001 mm / 0.00005 in
- Conversion mm/in
- Micrometer element with a max. perm. error of 4 µm
- Hardened steel
- 7,5 mm diameter non-rotating spindle. With a fixing bore for a measuring insert. Adjustable attachment on the anvil for a measuring insert, with lock.
- Plastic case
- Inspection report with a declaration of conformity
- Identification number
- RS232
- Additional technical data: see standard
- Max. 10 N

Full Set of Measuring Inserts for MICROMASTER with Interchangeable Inserts

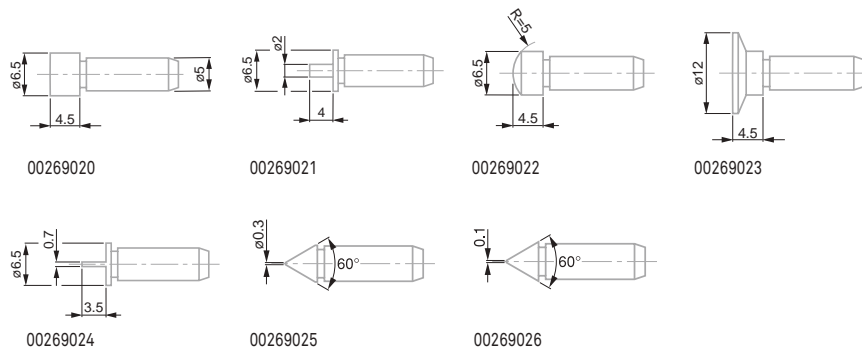

No	=
00269027	Full set of 7 pairs of inserts
COMPOSITION OF THE SETS:	
00269020	Pair of flat inserts
00269021	Pair of spline inserts
00269022	Pair of spherical inserts
00269023	Pair of disc inserts
00269024	Pair of blade inserts
00269025	Pair of point inserts
00269026	Pair of knife edge inserts

- DIN 863 T3 (Style D 10)
- 0,001 mm / 0.00005 in
- Conversion mm/in
- Tungsten carbide
- Plastic case
- Inspection report with a declaration of conformity
- Identification number
- RS232
- Additional technical data: see standard.
- 0,75 mm for 3-flute test pieces or 0,559 mm for 5-flute test pieces.
- Max. 10 N
- Angle of the prism aperture: 60° for 3-flute test pieces or 108° for 5-flute test pieces.

MICROMASTER Micrometers with Prismatic Measuring Faces

Measure test pieces with an odd number of grooves such as milling cutters, taps, drills and spline shafts as well as polygons. Determine roundness errors on cylindrical surfaces. The angle of the prism aperture is designed for workpieces having 3 or 5 flutes.

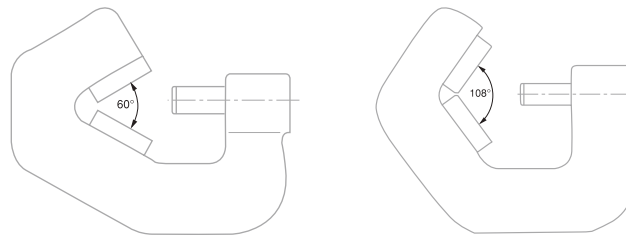

No	mm		A
	mm	in	
06030087	1 ÷ 7	0.04 ÷ 0.27	3 flute test pieces (60°)
06030088	5 ÷ 20	0.20 ÷ 0.80	3 flute test pieces (60°)
06030089	20 ÷ 35	0.80 ÷ 1.38	3 flute test pieces (60°)
06030090	35 ÷ 50	1.38 ÷ 1.97	3 flute test pieces (60°)
06030091	50 ÷ 65	1.97 ÷ 2.56	3 flute test pieces (60°)
06030092	65 ÷ 80	2.56 ÷ 3.15	3 flute test pieces (60°)
06030093	1 ÷ 7	0.04 ÷ 0.27	5 flute test pieces (108°)
06030094	5 ÷ 25	0.20 ÷ 0.98	5 flute test pieces (108°)
06030095	25 ÷ 45	0.98 ÷ 1.77	5 flute test pieces (108°)
06030096	45 ÷ 65	1.77 ÷ 2.56	5 flute test pieces (108°)
06030097	65 ÷ 85	2.56 ÷ 3.35	5 flute test pieces (108°)

- Alloyed steel, hardened
- With a protective cap from the nominal size of 20 mm. Effective diameter engraved on the front face.
- Declaration of conformity
- Identification number

Cylindrical Setting Standards for Micrometers

No	μm		Ø
	μm	μm	
00440001	0,5	-	5
00440002	0,7	1	20
00440003	0,7	1	25
00440004	1	1	35
00440005	1,2	1,5	45
00440006	1,2	1,5	50
00440007	1,5	1,5	65



MICROMASTER AC Micrometers for Thread Measurement

Used for pitch diameter inspection. Anvil with adjustable holder for mounting a measuring insert with prismatic faces. Fine screw adjustment and locking device. The spindle has a fixing bore for a cone-shaped measuring insert.



No	mm	in
06030062	0 ÷ 25	0 ÷ 1
06030063	25 ÷ 50	1 ÷ 2
06030064	50 ÷ 75	2 ÷ 3
06030065	75 ÷ 100	3 ÷ 4
06030066	100 ÷ 125	4 ÷ 5
06030067	125 ÷ 150	5 ÷ 6

Note: Measuring inserts and setting standards must be ordered separately.

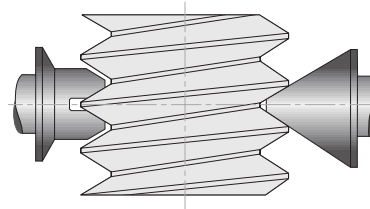

- DIN 863 T3 (Style D18)
- 0,001 mm / 0.00005 in
- Conversion mm/in
- Plastic case
- Inspection report with a declaration of conformity
- Identification number
- RS232
- Additional technical data: see appropriate standard
- Max. 10 N
- 30 mm measuring span

ISOMASTER AC Micrometers for Thread Measurement Models



No	mm
00210001	0 ÷ 25
00210002	25 ÷ 50
00210003	50 ÷ 75
00210004	75 ÷ 100

Measuring inserts and setting standards must be ordered separately.

- DIN 863 T3 (Style D 18) NFE 11-090
- Plastic case
- Declaration of conformity
- Identification number
- 0,5 mm
- Max. 10 N
- 0,01 mm



Hardened steel



Supplied in sets or pairs

Fixing rod:
3,5 mm dia.,
15,5 mm long

Interchangeable Thread Inserts for TESA Micrometers Series AC

With measuring faces specially designed for checking pitch diameters.



For unified inch threads, UN, UNC, UNF... 60° flank angle

For Whitworth threads, 55° flank angle

For ISO metric threads, flank angle 60°



00250015 Set of inserts
64 ÷ 2.5 in

COMPOSITION OF THE SETS:

00250000 AC UN,UNC,UNF
64 ÷ 42 in

00250001 AC UN,UNC,UNF
42 ÷ 25 in

00250002 AC UN,UNC,UNF
25 ÷ 17 in

00250003 AC UN,UNC,UNF
17 ÷ 10 in

00250004 AC UN,UNC,UNF
10 ÷ 6.5 in

00250005 AC UN,UNC,UNF
6.5 ÷ 4 in

00250006 AC UN,UNC,UNF
4 ÷ 2.5 in



00250115 Set of inserts, whitworth
60 ÷ 3 in

COMPOSITION OF THE SETS:

00250100 AC whitworth 60 ÷ 48 in

00250101 AC whitworth 48 ÷ 40 in

00250102 AC whitworth 40 ÷ 32 in

00250103 AC whitworth 32 ÷ 24 in

00250104 AC whitworth 24 ÷ 18 in

00250105 AC whitworth 18 ÷ 14 in

00250106 AC whitworth 14 ÷ 10 in

00250107 AC whitworth 10 ÷ 7 in

00250108 AC whitworth 7 ÷ 4.5 in

00250109 AC whitworth 4.5 ÷ 3 in



00240015 Set of inserts
ISO 0.40 ÷ 6.00

COMPOSITION OF THE SETS:

00240000 ISO 0.4 ÷ 0.50

00240001 ISO 0.5 ÷ 0.60

00240002 ISO 0.6 ÷ 0.80

00240003 ISO 0.8 ÷ 1.00

00240004 ISO 1.0 ÷ .25

00240005 ISO 1.25 ÷ 1.50

00240006 ISO 1.5 ÷ 2.00

00240007 ISO 2.00 ÷ 2.50

00240008 ISO 2.5 ÷ 3.00

00240009 ISO 3.00 ÷ 4.00

00240010 ISO 4.00 ÷ 5.00

00240011 ISO 5.0 ÷ 6.00



Hardened steel

Insulating sleeve
marked
with actual sizeDeclaration
of conformityIdentification
number

Setting Standards for Screw Thread Micrometers - Metric, 60° or 55° flank angle



60° flank angle, metric

60° flank angle, imperial

55° flank angle, metric



Flank angle mm

00240501 60° 25

00240502 60° 50

00240503 60° 75

00240504 60° 100

00240505 60° 125



Flank angle in

00250501 60° 1

00250502 60° 2

00250503 60° 3

00250504 60° 4

00250505 60° 5



Flank angle mm

00240601 55° 25

00240602 55° 50

00240603 55° 75



XB Wires for Screw Threads

For measuring pitch diameter of threads using the three-wire method. Actual flank diameter d_2 can either be determined arithmetically or with the aid of the relevant tables based on the measured actual size M – Suitable for all standard micrometers with measuring faces of 6,5 mm diameter.

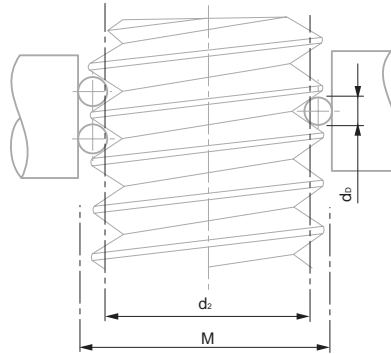
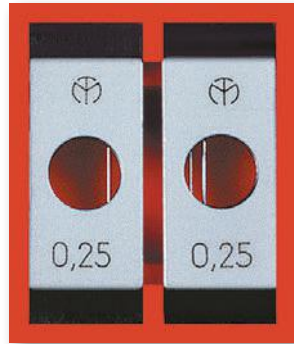

No	\varnothing Diameter of the wires dD in mm	 ISO metric threads Pitch in mm	 Whitworth threads Number of threads per in	 Unified inch-threads UN, UNC, UNF Number of threads per in
00240701	0,17	0,25 / 0,3	–	–
00240702	0,22	0,35	–	72
00240703	0,25	0,4	60	64
00240704	0,29	0,45 / 0,5	–	56
00240705	0,335	0,6	48 / 40	48 / 44
00240706	0,455	0,7 ÷ 0,8	–	32
00240707	0,53	0,9	32 / 28	28
00240708	0,62	1,0	26 / 24	24
00240709	0,725	1,25	22 ÷ 19	20
00240710	0,895	1,5	18 / 16	18 / 16
00240711	1,10	1,75	14	14 / 13
00240712	1,35	2,0	12 / 11	12 / 11
00240713	1,65	2,5	10 / 9	10 / 9
00240714	2,05	3,0 / 3,5	8 / 7	8 / 7
00240715	2,55	4,0 / 4,5	6	6
00240716	3,20	5,0 / 5,5	5 / 4,5	5 / 4,5

Set of 16 Pairs of XB Wires for Thread Measurement

No	\varnothing Diameter of the wires dD in mm
00240700	0,17 ÷ 3,20



Steel wires, hardened

Single pairs are supplied in a plastic box, full set in a wooden case

Declaration of conformity

Wires are mounted on holders: 2-wire holder rests on anvil while the single wire holder is used on spindle side



Wires in hardened steel

Single pairs supplied in a plastic case, full set in a wooden box.

Declaration of conformity

Wires mounted on holders: the 2 wire holder rests on the anvil, whilst the single wire holder is used on the spindle side.

ETALON Basic for Tube Wall Thickness Measurement

Barrel-shaped anvil for measuring tube wall thickness and other curved workpieces.

- DIN 863 T3 (Style D12) NFE 11-090
- Hardened steel anvil. Tungsten carbide spindle
- Plastic case
- Inspection report with a declaration of conformity
- Identification number
- 0,5 mm
- Max. 10 N
- 5 mm Ø on anvil. 6,5 mm Ø on spindle
- 0,01 mm



00219066	mm 0 ÷ 25

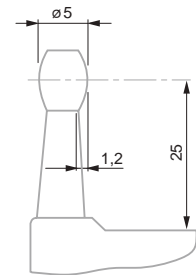

MICROMASTER with Interchangeable Anvils

All sets include 4 interchangeable anvils with increasing length in steps of 25 mm. The anvils are adjusted (and numbered) in sets, thus rendering the correction of the indication unnecessary whenever an anvil is exchanged.

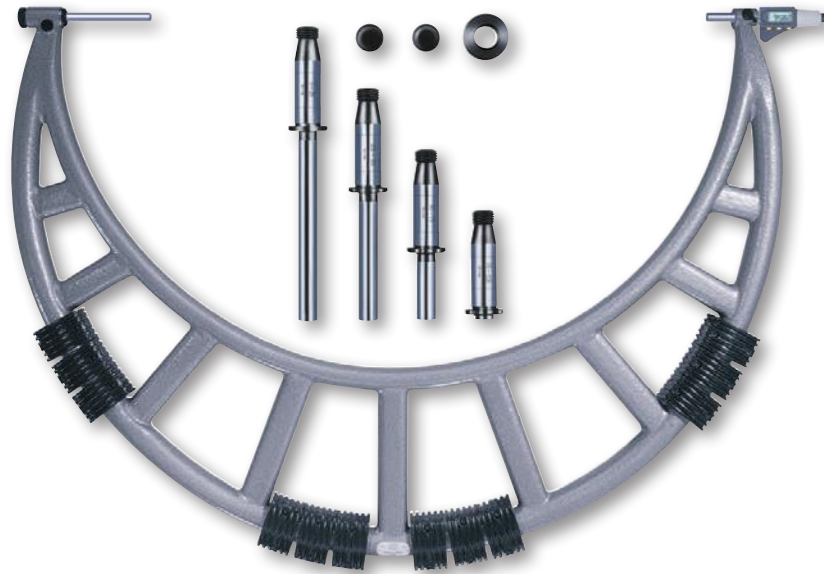

No				
	mm	in	µm	µm
06030047	0 ÷ 100	0 ÷ 3.94	6	3
06030048	100 ÷ 200	3.94 ÷ 7.87	7	4,5
06030049	200 ÷ 300	7.87 ÷ 11.81	8	7
06030050	300 ÷ 400	11.81 ÷ 15.75	9	9
06030051	400 ÷ 500	15.75 ÷ 19.69	10	9

OPTIONAL ACCESSORIES:

- 00140301 Dial gauge element for ABY series micrometers
- 00140101 Interchangeable anvils AB1W

Measuring range up to 1500 mm also available upon request.



Dial Gauge Element for MICROMASTER and AB Micrometers

Can replace the interchangeable anvils on AB series micrometers. Makes finding the culmination point easier. Ensures a constant measuring force.

No	
00140301	Dial gauge element for ABY series micrometers

- 0,001 mm / 0,00005 in
- LCD, digit height: 7 mm
- Conversion mm/in
- Tungsten carbide tipped
- Wooden case
- Inspection report with declaration of conformity
- Identification number
- RS232
- Additional technical data: see standard
- 0,5 mm
- Max. 10 N
- Ø 8 mm
- 30 mm measuring span
- 0 ≤ 500 mm: malleable cast iron.
> 500 ≤ 1000 mm: steel tube with insulating grips. Maxium flexing of the frame under a measuring force of 10 N: see table
- Element body: Ø 11 mm, length 100 mm. Dial gauge 01410211: dial Ø 40 mm, two directional reading.
- With dial gauge and clamp
- Declaration of conformity
- Identification number
- Max. 10 N
- Ø 8 mm
- 0,01 mm
- ± 1,5 mm

- DIN 863 T3 (Style D16) NFE 11-090
- Tungsten carbide tipped
- Wooden case
- Declaration of conformity
- Identification number
- 0,5 mm
- Max. 10 N
- 8 mm diameter
- 0,01 mm
- 0 ≤ 500 mm: malleable cast iron; 500 ≤ 1000 mm: steel tube with insulating grips. Max. flexure of the frame under a measuring force of 10 N: see the table opposite

ISOMASTER AB with Interchangeable Anvils

Lightweight, but rugged anvil micrometers. Set No. 00140101 includes 4 interchangeable anvils with increasing length in steps of 25 mm.

Anvils are adjusted and numbered in pairs, thus rendering any correction of the indication unnecessary whenever an anvil is exchanged.



No			
	mm	μm	μm
00111901	0 ÷ 100	6	3
00111902	100 ÷ 200	7	4,5
00111903	200 ÷ 300	8	7
00111904	300 ÷ 400	9	9
00111905	400 ÷ 500	10	9

OPTIONAL ACCESSORIES:

00140101	Interchangeable anvils AB1W
00140301	Dial gauge element for ABY series micrometers

Measuring range up to 1500 mm also available upon request.

Interchangeable Anvils for ISOMASTER ABY Series

Set of 4 interchangeable anvils with increasing length in steps of 25 mm. The anvils are adjusted and numbered in pairs, thus eliminating the need for resetting the indication when exchanging either of them. Supplied as standard accessories with the AB series micrometers.



No	
00140101	Interchangeable anvils AB1W

- DIN 863 T3 (Style D16) NFE 11-090
- Tungsten carbide tipped
- Set includes 2 guard plates for the frame as well as 1 clamping nut
- Identification number
- 8 mm diameter



INTERAPID Setting Standards

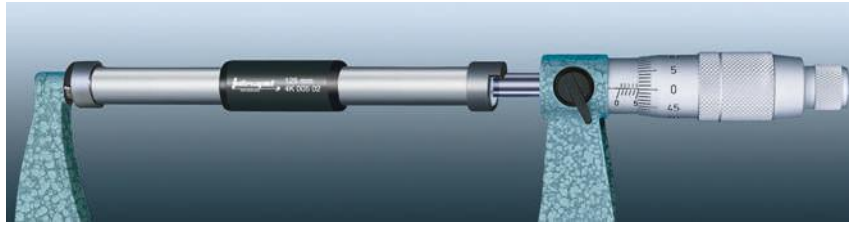
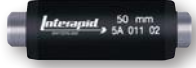

No	mm
02140001	25
02140002	50
02140003	75
02140004	100
02140005	125
02140006	150
02140007	175
02140008	200
02140009	225
02140010	250

No	mm
02140011	275
02140012	300
02140013	325
02140014	350
02140015	375
02140016	400
02140017	425
02140018	450
02140019	475
02140020	500

Measuring range up to 1500 mm also available upon request.

ETALON Cylindrical Step Gauges

For adjustment of the display and calibration.



No	mm
072112020	5 ÷ 100
072112021	5 ÷ 150

Guide Collars for Setting Standards

Making the positioning of INTERAPID setting standards quick and easy.



No	mm	mm
02140103	100 ÷ 175	8
02140108	200 ÷ 1475	8

- Maximum permissible error over the length: $\pm (1 + L/100) \mu\text{m}$, L in mm
- Hardened steel
- Inspection report with actual measured length
- Declaration of conformity
- Identification number
- Cylindrical gauge block with plastic insulating grip and dull chrome shaft
- Two measuring faces, flat and rounded
- With lengths: $\leq 175 \text{ mm} = 10 \text{ mm}$, $\geq 200 \text{ mm} = 13 \text{ mm}$.

- Maximum permissible errors for nominal diameters: $\leq 80 \text{ mm} = 1,5 \mu\text{m}$, $\geq 90 \leq 120 \text{ mm} = 2,0 \mu\text{m}$, $\geq 130 \text{ mm} = 2,5 \mu\text{m}$
- Alloyed steel, hardened
- Declaration of conformity
- Mounted on a wooden base. Supplied with dust cover.
- Diameters in steps of 5 mm ($\leq 50 \text{ mm}$) or 10 mm ($> 50 \text{ mm}$).





Angle can be locked using a single bolt.



Lacquered cast iron base



Clamp aperture: 16 mm (TESA) or 20 mm (ETALON)

Micrometer Stands

For external micrometers up to 300 mm as well as many other hand-held tools.



No

=

00160201 TESA micrometer stand with clamp aperture 16 mm

072110123 ETALON micrometer stand with clamp aperture 20 mm



Length tolerance with reference to the nominal dimension: $\pm 100 \mu\text{m}$



Each set is supplied in a wooden case



Declaration of conformity



Flatness tolerances for optical parallels with lengths:
 $\leq 27,335 \text{ mm}$
 $= 0,15 \mu\text{m}$ $\geq 52,00 \div 77,335 \text{ mm} = 0,2 \mu\text{m}$



Tolerances in parallelism for optical parallels with lengths:
 $\leq 27,335 \text{ mm}: 0,4 \mu\text{m}$
 $\geq 52,00 \div 77,335 \text{ mm}: 0,5 \mu\text{m}$



31 mm

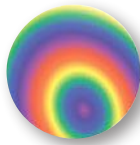
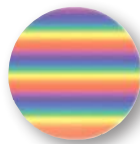

Optical Flats with Two Parallel Faces

Used for examining the flatness and parallelism of the measuring faces on external micrometers as well as other similar measuring instruments. The difference in length of the optical flats within a set matches a quarter or a third of the spindle pitch of 0,5 mm.



No

=



mm

02510000	Set interference glass 12 \div 12,375 mm	12,00 \div 12,375
02510001	Interference glass 12	12,00
02510002	Interference glass 12,125	12,125
02510003	Interference glass 12,25 mm	12,25
02510004	Interference glass 12,375 mm	12,375
02510100	Set interference glass 27 \div 27,335 mm	27,00 \div 27,335
02510101	Interference glass 27 mm	27,00
02510102	Interference glass 27,165 mm	27,165
02510103	Interference glass 27,335 mm	27,335
02510200	Set interference glass 52 - 52,3	52,00 \div 52,335
02510201	Interference glass 52 mm	52,00
02510202	Interference glass 52,165 mm	52,165
02510203	Interference glass 52,335 mm	52,335
02510300	Set interference glass 77 \div 77,335 mm	77,00 \div 77,335
02510301	Interference glass 77,00 mm	77,00
02510302	Interference glass 77,165 mm	77,165
02510303	Interference glass 77,335 mm	77,335



MICROMASTER Depth Micrometers

Non-rotating measuring rod. Sets with a step length of 30 mm.



No	mm	in	mm
06030069	0 ÷ 90	0 ÷ 3.5	50 x 15
06030070	0 ÷ 180	0 ÷ 7	100 x 15

Set of Depth Rods for Micromaster

Set of 6 depth rods.



No	mm
06060021	0 ÷ 180

ISOMASTER AQ Depth Micrometers

Measuring rods with a step length of 25 mm.



No	mm	mm
00211002	0 ÷ 75	50 x 15
00211003	0 ÷ 150	50 x 15
00211004	0 ÷ 75	100 x 15
00211005	0 ÷ 150	100 x 15

- DIN 863 T2 (Style T)
 - 0,001 mm / 0.00005 in
 - Conversion mm/in
 - Max. perm. error (meas. element): 3 µm
 - Measuring rods with hardened steel tips
 - Non-rotating spindle
 - Plastic case
 - Inspection report with a declaration of conformity
 - Identification number
 - RS232 data output
 - 0,5 mm
 - 3 mm diameter measuring rods
 - 30 mm
-
- DIN 863 T2 (Style T) NFE 11-097
 - Max. perm. error of the measuring element: 3 µm
 - Measuring rods with hardened steel ends
 - Plastic case
 - Declaration of conformity
 - Identification number
 - 0,5 mm
 - 3 mm diameter measuring rods. Measuring face on the base: see table
 - 0,01 mm

- +
- DIN 863 T2 (Style E)
- 0,001 mm / 0,00005 in
- Conversion mm/in
- Max. perm. error of 4 µm
- Tungsten carbide tipped
- Inspection report with a declaration of conformity
- RS232 interface, opto-coupled
- Additional technical data: see standard
- 0,5 mm
- Max. 10 N
- 6,5 mm dia.

MICROMETER HEADS

Micrometer heads used principally for the measurement of displacement on special fixtures such as roller tables, XY tables. Mounted using the cylindrical coupling shaft.

MICROMASTER Micrometer Heads

Without spindle lock



No		
	mm	
06030038	0 ÷ 30	12h6
06030039	30 ÷ 0	12h6
06030040	30 ÷ 0	12h6

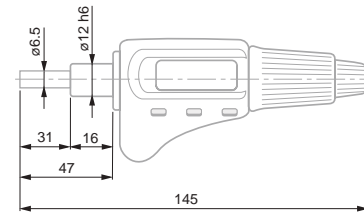

- +
- DIN 863 T2 (Style E)
- Value of the scale: 0,1 mm
- Max. perm. error of 2 µm
- Tungsten carbide tipped
- Declaration of conformity
- Identification number
- 0,5 mm
- Max. 10 N
- 6,5 mm dia.
- Vernier reading to 0,001 mm

TESAMASTER AR Micrometer Heads

Without spindle lock.



No		
	mm	
00312301	0 ÷ 25	12h6

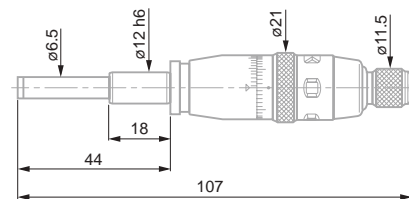

ETALON 266 Micrometer Heads

With spindle lock.

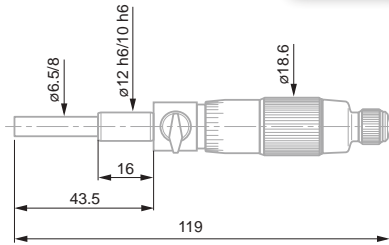

072115943	0 ÷ 25	Ø 8	12h6	•

- DIN 863 T2 (Style E) NFE 11-090
- Max. perm. error: 3 µm
- Tungsten carbide tipped
- Declaration of conformity
- Identification number
- 0,5 mm
- Vernier reading to 0,002 mm

ISOMASTER AR Micrometer Heads

Without spindle lock.

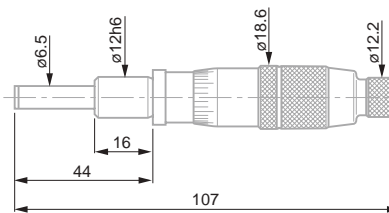

00211201	0 ÷ 25	12h6

- DIN 863 T2 (Style E) NFE 11-090
- Max. perm. error of 3 µm
- Tungsten carbide tipped
- Declaration of conformity
- Identification number
- 0,5 mm
- Max. 10 N
- 6,5 mm dia
- 0,01 mm





DIN 862

Stainless steel,
hardenedInspection report
with a declaration
of conformityTechnical data:
according to the
appropriate
standardTungsten carbide
tipped

TOOL SETS

Tool sets for the workshop, including one caliper and one micrometer.
Several digital and analogue models to choose from. Ideal tool sets for apprentices.

TESA SWISS TOOL SET



No

=

00510033 TESA SWISS TOOL SET 0-25 mm micrometer, 0-150 mm caliper

CONSISTING OF:

No

=



mm

00510041 Vernier caliper with measuring range of 150 mm and
resolution of 0,02 mm

0 ÷ 150

00560013 Depth foot for calipers up to 150 mm

00110101 ISOMASTER AA external micrometer with vernier scale,
0 ÷ 25 mm and resolution to 0,01 mm

0 ÷ 25

00560031 Case for set of instruments



TESA DUO-SET 1



- ISO 13385-1
- Stainless steel, hardened
- Inspection report with a declaration of conformity
- Technical data: see appropriate standard
- Tungsten carbide tipped

No	=	
00530020	TESA DUO-SET 1	
CONSISTING OF:		
No	=	
00510008	CCMA-M dial caliper with measuring range of 150 mm, resolution to 0,02 mm and 2 mm travel per revolution.	mm 0 ÷ 150
00560013	Depth foot for calipers up to 150 mm	
00110101	ISOMASTER AA external micrometer with vernier scale, 0 ÷ 25 mm and resolution to 0,01 mm	0 ÷ 25
00560031	Case for set of instruments	

TESA DUO-SET 2



- DIN 862
- Stainless steel, hardened
- Inspection report with a declaration of conformity
- Technical data: according to the appropriate standard
- Tungsten carbide tipped

No	=	
00530021	TESA DUO-SET 2	
CONSISTING OF:		
No	=	
00510008	CCMA-M dial caliper with measuring range of 150 mm, resolution to 0,02 mm and 2 mm travel per revolution.	mm 0 ÷ 150
00560013	Depth foot for calipers up to 150 mm	
00310001	TESAMASTER external micrometer with measuring range 0 ÷ 25 mm and vernier scale reading to resolution 0,001 mm.	0 ÷ 25
00560031	Case for set of instruments	



DIN 862

Stainless steel,
hardenedInspection report
with a declaration
of conformityTechnical data:
in accordance with
appropriate standardTungsten
carbide tipped

TESA DUO-SET 8



No **=**

00531101 TESA DUO-SET 8

CONSISTING OF:

No **=**



mm

00530094 Standard TWIN-CAL, electronic caliper, with measuring range 150 mm, resolution of 0,01 mm and IP40 protection rating. Round depth rod. 0 ÷ 150

00560013 Depth foot for calipers up to 150 mm

00110101 ISOMASTER AA external micrometer with vernier scale, 0 ÷ 25 mm and resolution to 0,01 mm 0 ÷ 25

00560031 Case for set of instruments



DIN 862

Stainless steel,
hardenedInspection report
with a declaration
of conformityTechnical data:
according to the
appropriate
standardTungsten
carbide tipped

TESA DUO-SET 9



No **=**

00531102 TESA DUO-SET 9

CONSISTING OF:

No **=**



mm

00530094 Standard TWIN-Cal, electronic caliper, with measuring range 150 mm, 0 ÷ 150 mm resolution of 0,01 mm and IP40 protection rating. Round depth rod.

00560013 Depth foot for calipers up to 150 mm

00310001 TESAMASTER external micrometer with measuring range 0 ÷ 25 mm and vernier scale reading to resolution 0,001 mm. 0 ÷ 25

00560031 Case for set of instruments



TESA DUO-SET 14



- ISO 13385-1
- Stainless steel, hardened
- SCS calibration certificate
- Technical data: see appropriate standard
- Tungsten carbide tipped

No	=	
00531005		TESA DUO-SET 14
CONSISTING OF:		
No	=	mm
00530320		TWIN-Cal electronic caliper with measuring range 150 mm, resolution 0,01 mm, IP67 rating and round depth rod. 0 ÷ 150
00560013		Depth foot for calipers up to 150 mm
06030010		MICROMASTER EASY digital micrometer, 0 ÷ 30 mm, 0,001 mm resolution. 0 ÷ 30
00560090		Case for set of instruments

TESA DUO-SET 13



- ISO 13385-1
- Stainless steel, hardened.
- SCS calibration certificate
- Technical data: see appropriate standard
- Tungsten carbide tipped

No	=	
00531004		TESA DUO-SET 13
CONSISTING OF:		
No	=	mm
00530319		TWIN-Cal electronic caliper with measuring range 150 mm, resolution 0,01 mm, IP67 rating and square depth rod. 150
00560013		Depth foot for calipers up to 150 mm
06030020		MICROMASTER IP54 digital micrometer, 0 ÷ 30 mm, 0,001 mm resolution, IP54 rating. 0 ÷ 30
00560090		Case for set of instruments



ISO 13385-1

Stainless steel,
hardenedSCS calibration
certificateTechnical data:
see appropriate
standardTungsten
carbide tipped

TESA DUO-SET 15



No **=**

00531006 TESA DUO-SET 15

CONSISTING OF:

No **=**



mm

00530321 TWIN-Cal electronic caliper with measuring range 150 mm, resolution 0 ÷ 150 0,01 mm, IP67 rating, round depth rod and thumb wheel.

00560013 Depth foot for calipers up to 150 mm

06030030 MICROMASTER RS IP54 digital micrometer, 0 ÷ 30 mm, 0,001 mm resolution, IP54 rating and RS232 output.

00560090 Case for set of instruments



DIN 862

Stainless steel,
hardenedSCS calibration
certificateTechnical data:
see appropriate
standardTungsten
carbide tipped

TESA DUO-SET 16



No **=**

00531007 TESA DUO-SET 16

CONSISTING OF:

No **=**



mm

00530094 Standard TWIN-Cal, electronic caliper, with measuring range 150 mm, 150 resolution of 0,01 mm and IP40 protection rating. Round depth rod.

00560013 Depth foot for calipers up to 150 mm

06030010 MICROMASTER EASY digital micrometer, 0 ÷ 30 mm, 0,001 mm resolution.

00560090 Case for set of instruments





Internal Measurement

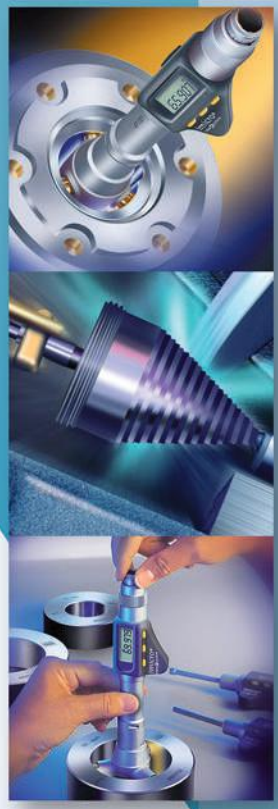

THE CHALLENGES OF INTERNAL MEASUREMENT

Bore measurement is more difficult than external measurement of components. Apart from the very tight tolerances specified, all measuring elements having a direct influence on the uncertainty of measurement must be designed in such a way that they can fit into the bore to be checked.

3-LINE CONTACT OFFERS A TRUE ADVANTAGE

The near perfect auto-centering and auto alignment provided by TESA IMICRO, TESA TRI-O-BOR, ALESOMETER and ETALON INTALOMETER make bore measurement reliable, without the need for an operator to estimate.

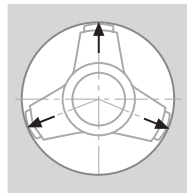

The three measuring bolts are spaced 120° apart, thus providing optimum self-centring.

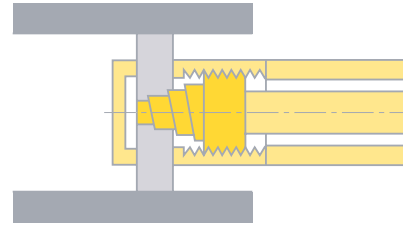

The measuring bolts with 3-line contact allows the micro-meter to align itself parallel to the contact surfaces.

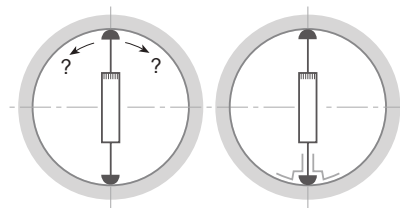

2-point contact measuring instruments are not self-centring. To enable bore measurements, the use of auxiliary means are required.

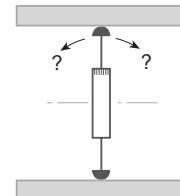

2-point contact does not permit the tool to align itself in relation to the bore axis.

A SINGLE TOOL CAN REPLACE HUNDREDS OF PLUG GAUGES

Unlike plug gauges that check only one toleranced size, a single tool can measure many diameters. Depending on the model that is being used, through holes and blind bores along with short centring shoulders can be inspected reliably.



ESTABLISHING FORM ERRORS

Form errors are established through measurements taken at several points within a bore. Micrometers with 3-line contact determine run-out errors in a triangular way. Micrometers with 2-point contact measure medium-size diameters only. They do not allow users to see what makes diameters measured at various points different.

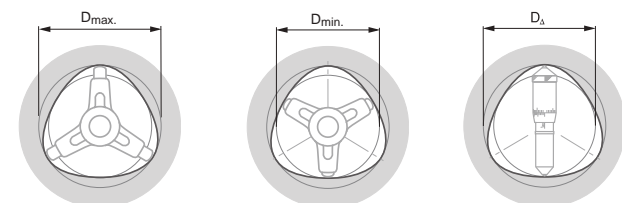
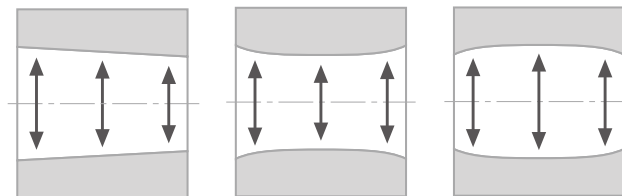

TESA IMICRO with Analogue Indication – Metric

Self-centring and self-aligning internal micrometers. The high-precision thread machined into the measuring cone, combined with the measuring bolts specially arranged to provide 3-line contact, make them the only micrometers in the world that respect the ABBE principle. Measure depth, reliably.

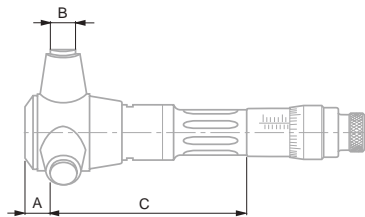
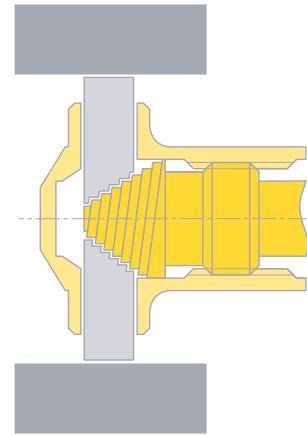
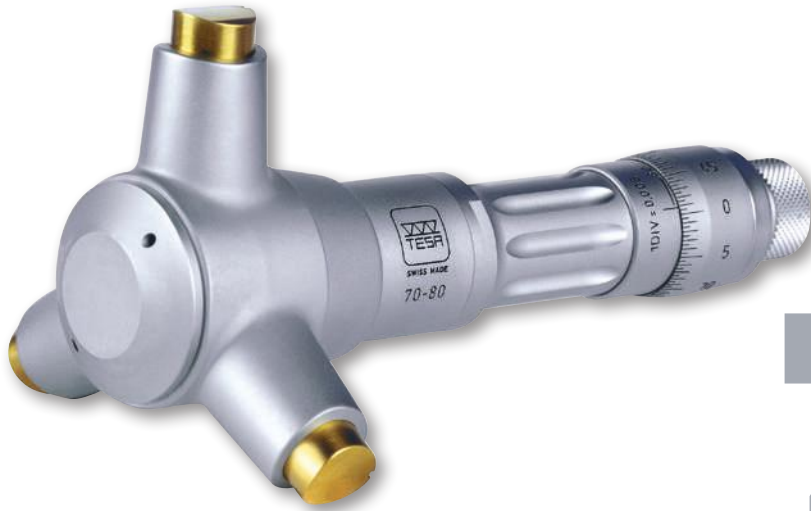

DIN 863 T4
(Style C1)
NFE 11-099

Measuring faces for application ranges from 3,5 to 12 mm: hardened steel (HV30 770)
11 to 100 mm: TiN hard-coating (HV5 2300)
100 to 300 mm: carbide tipped (HV5 1300)

Application ranges from 3,5 to 200 mm in a shipping box
200 to 300 mm in a wooden case with 1 extension of 150 mm (No. 00842600)

Inspection report with a declaration of conformity

Identification number

No							
	mm	mm	µm	µm	A mm	B mm	C mm
00813410	3,5 ÷ 4	0,001	4	4	2	1,5	20
00813411	4 ÷ 4,5	0,001	4	4	2	1,5	20
00813412	4,5 ÷ 5,5	0,001	4	4	2	1,5	25
00813413	5,5 ÷ 6,5	0,001	4	4	2	1,5	25
00810001	6 ÷ 8	0,001	4	4	2,5	2,5	52
00810002	8 ÷ 10	0,001	4	4	2,5	2,5	52
00810003	10 ÷ 12	0,001	4	4	2,5	2,5	52
00810801	11 ÷ 14	0,005	4	4	3,5	4	77
00810802	14 ÷ 17	0,005	4	4	3,5	4	77
00810803	17 ÷ 20	0,005	4	4	3,5	4	77
00811501	20 ÷ 25	0,005	4	4	7	7	78
00811502	25 ÷ 30	0,005	4	4	7	7	78
00811503	30 ÷ 35	0,005	4	4	7	7	78
00811504	35 ÷ 40	0,005	4	4	7	7	78
00812301	40 ÷ 50	0,005	4	4	11	12	84
00812302	50 ÷ 60	0,005	5	5	11	12	84
00812303	60 ÷ 70	0,005	5	5	11	12	84
00812304	70 ÷ 80	0,005	5	5	11	12	84
00812305	80 ÷ 90	0,005	5	5	11	12	84
00812306	90 ÷ 100	0,005	5	5	11	12	84
00812601	100 ÷ 125	0,01	6	6	26	18	81
00812602	125 ÷ 150	0,01	6	6	26	18	81
00812603	150 ÷ 175	0,01	7	7	26	18	81
00812604	175 ÷ 200	0,01	7	7	26	18	81
00813101	200 ÷ 225	0,01	8	8	26	18	81
00813102	225 ÷ 250	0,01	8	8	26	18	81
00813103	250 ÷ 275	0,01	8	8	26	18	81
00813104	275 ÷ 300	0,01	8	8	26	18	81



TESA IMICRO with Analogue Indication – Full Metric Sets



DIN 863 T4
(Style C1)
NFE 11-099



Measuring faces
on models from
3,5 to 12 mm:
hardened steel,
HV30 770;
11 to 100 mm: tita-
nium nitride (TiN)
hard-coating to
HV5 2300.
100 to 200 mm:
tungsten carbide
tipped to HV5 1300.



Plastic case
or suitcase



Inspection report
with a declaration
of conformity



Identification
number



mm



Isolated
instruments



mm



Setting
rings



mm



Extensions



A mm

COMPOSITION OF THE SETS:

00813409	BAE	3,5 ÷ 6,5	00813410	3,5 ÷ 4	00843200	4		
			00813411	4 ÷ 4,5	00843201	5,5		
			00813412	4,5 ÷ 5,5				
			00813413	5,5 ÷ 6,5				
00810000	BAF	6 ÷ 12	00810001	6 ÷ 8	00840101	8	00840001	100
			00810002	8 ÷ 10	00840102	10		
			00810003	10 ÷ 12				
00810800	BAG	11 ÷ 20	00810801	11 ÷ 14	00840103	11	00840301	150
			00810802	14 ÷ 17	00840105	17		
			00810803	17 ÷ 20				
00811500	BAH	20 ÷ 40	00811501	20 ÷ 25	00840106	25	00841100	150
			00811502	25 ÷ 30	00840107	35		
			00811503	30 ÷ 35				
			00811504	35 ÷ 40				
00812300	BAJ	40 ÷ 100	00812301	40 ÷ 50	00840108	50	00841800	150
			00812302	50 ÷ 60	00840109	70		
			00812303	60 ÷ 70	00840110	90		
			00812304	70 ÷ 80				
			00812305	80 ÷ 90				
			00812306	90 ÷ 100				
00812600	BAK	100 ÷ 200	00812601	100 ÷ 125	00840112	125	00842600	150
			00812602	125 ÷ 150	00840113	175		
			00812603	150 ÷ 175				
			00812604	175 ÷ 200				

TESA IMICRO CAPA μ SYSTEM with Digital Display

A successful combination of the patented TESA capacitive system with the IMICRO unique cone.

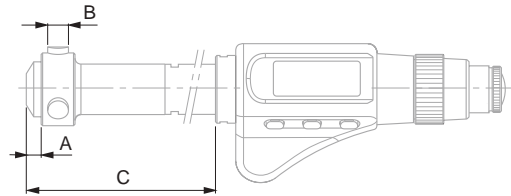

DIN 863 T4
(Style C1)



0,001 mm
0,00005 in



LCD, 7 mm
digit height



Floating zero



Metric/inch
Conversion



Measuring faces
for application
ranges 3,5 to 12 mm:
hardened steel
(770 HV 30)
11 to 100 mm:
TiN hard-coating
(2300 HV 5)
100 to 300 mm:
carbide tipped
(1300 HV 5)



3 V lithium battery



1 to 2 a
(\approx 2000 h/a)



Automatic shut
down after 10 min.
Display setting is
retained as long as
power supply
remains stable.



-10°C to 60°C



10°C to 40°C



80 %, non
condensing



Measuring
element IP54
(IEC 60529) or
IP40 with active
data output



Plastic case



TESA's
calibration
certificate



Declaration
of conformity



Identification
number



Display lock



RS232
opto-coupled,
bidirectional

No	mm	in	μ m	μ m	A mm	B mm	C mm
06130101	3,5 ÷ 4	0.1377 ÷ 0.1574	4	4	2	1,5	20
06130102	4 ÷ 4,5	0.1574 ÷ 0.1771	4	4	2	1,5	20
06130103	4,5 ÷ 5,5	0.1771 ÷ 0.2165	4	4	2	1,5	25
06130104	5,5 ÷ 6,5	0.2165 ÷ 0.2559	4	4	2	1,5	25
06130105	6 ÷ 8	0.2362 ÷ 0.3150	4	4	2,5	2,5	79
06130106	8 ÷ 10	0.3150 ÷ 0.3970	4	4	2,5	2,5	79
06130107	10 ÷ 12	0.3970 ÷ 0.4724	4	4	2,5	2,5	79
06130108	11 ÷ 14	0.4330 ÷ 0.5512	4	4	3,5	4	93
06130109	14 ÷ 17	0.5512 ÷ 0.6693	4	4	3,5	4	93
06130110	17 ÷ 20	0.6693 ÷ 0.7874	4	4	3,5	4	93
06130111	20 ÷ 25	0.7874 ÷ 0.9843	4	4	7	7	91
06130112	25 ÷ 30	0.9843 ÷ 1.1811	4	4	7	7	91
06130113	30 ÷ 35	1.1811 ÷ 1.3780	4	4	7	7	91
06130114	35 ÷ 40	1.3780 ÷ 1.5748	4	4	7	7	91
06130115	40 ÷ 50	1.5748 ÷ 1.9685	4	4	11	12	104
06130116	50 ÷ 60	1.9685 ÷ 2.3622	5	5	11	12	104
06130117	60 ÷ 70	2.3622 ÷ 2.7560	5	5	11	12	104
06130118	70 ÷ 80	2.7560 ÷ 3.1496	5	5	11	12	104
06130119	80 ÷ 90	3.1496 ÷ 3.5433	5	5	11	12	104
06130120	90 ÷ 100	3.5433 ÷ 3.9370	5	5	11	12	104
06130121	100 ÷ 125	3.9370 ÷ 4.9212	6	6	26	18	100
06130122	125 ÷ 150	4.9212 ÷ 5.9055	6	6	26	18	100
06130123	150 ÷ 175	5.9055 ÷ 6.8897	7	7	26	18	100
06130124	175 ÷ 200	6.8897 ÷ 7.8740	7	7	26	18	100
06130125	200 ÷ 225	7.8740 ÷ 8.8582	8	8	26	18	100
06130126	225 ÷ 250	8.8582 ÷ 9.8425	8	8	26	18	100
06130127	250 ÷ 275	9.8425 ÷ 10.8267	8	8	26	18	100
06130128	275 ÷ 300	10.8267 ÷ 11.8110	8	8	26	18	100

OPTIONAL ACCESSORY

01961000 1 Lithium battery 3V, CR2032



TESA IMICRO CAPA μ SYSTEM with Digital Display – Full Sets

A successful combination of the TESA patented capacitive measuring system with the IMICRO unique cone.

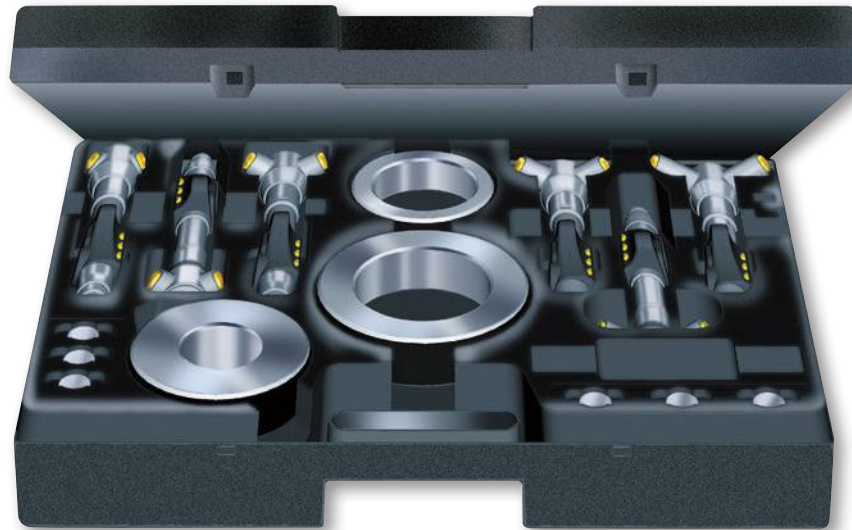

- DIN 863 T4 (Style C1)
- 0,001 mm / 0.00005 in
- LCD, 7 mm digit height
- Floating zero
- Metric/inch Conversion
- Measuring faces for application ranges 3,5 to 12 mm: hardened steel (770 HV 30)
11 to 100 mm: TIN hard-coating (2300 HV 5)
100 to 300 mm: carbide tipped (1300 HV 5)
- 3 V lithium battery
- 1 to 2 a (≈ 2000 h/a)
- Automatic shut down after 10 min. Display setting is retained as long as power supply remains stable.
- 10°C to 60°C
- 10°C to 40°C
- 80 %, non condensing
- Measuring element IP54 (IEC 60529) or IP40 with active data output
-
- Plastic case
- TESA's calibration certificate
- Declaration of conformity
- Identification number
- Display lock
- RS 232 opto-coupled, bidirectional

	mm	Singel micrometers	mm	Setting rings	mm	Extensions	mm
COMPOSITION OF THE SETS:							
06130220	3,5 ÷ 6,5	06130101	3,5 ÷ 4	00843200	4		
		06130102	4 ÷ 4,5	00843201	5,5		
		06130103	4,5 ÷ 5,5				
		06130104	5,5 ÷ 6,5				
06130221	6 ÷ 12	06130105	6 ÷ 8	00840101	8	00840001	100
		06130106	8 ÷ 10	00840102	10		
		06130107	10 ÷ 12				
06130222	11 ÷ 20	06130108	11 ÷ 14	00840103	11	00840301	150
		06130109	14 ÷ 17	00840104	17		
		06130110	17 ÷ 20				
06130223	20 ÷ 40	06130111	20 ÷ 25	00840106	25	00841100	150
		06130112	25 ÷ 30	00840107	35		
		06130113	30 ÷ 35				
		06130114	35 ÷ 40				
06130224	40 ÷ 100	06130115	40 ÷ 50	00840108	50	00841800	150
		06130116	50 ÷ 60	00840109	70		
		06130117	60 ÷ 70	00840110	90		
		06130118	70 ÷ 80				
		06130119	80 ÷ 90				
		06130120	90 ÷ 100				
06130225	100 ÷ 300	06130121	100 ÷ 125	00840112	125	00842600	150
		06130122	125 ÷ 150	00840113	175		
		06130123	150 ÷ 175				
		06130124	175 ÷ 200				

TESA IMICRO CAPA μ SYSTEM with Digital Display – Partial Sets

A successful combination of the TESA patented capacitive measuring system with the IMICRO unique cone.



- DIN 863 T4 (Style C1)
- 0,001 mm / 0.00005 in
- LCD, 7 mm digit height
- Floating zero
- Metric/inch Conversion
- Measuring faces for application ranges
3,5 to 12 mm: hardened steel (HV30 770)
11 to 100 mm: TiN hard-coating (HV5 2300)
100 to 300 mm: carbide tipped (HV5 1300)
- 3V lithium battery
- 1 to 2 a (\approx 2000 h/a)
- Automatic shut down after 10 min. Display setting is retained as long as power supply remains stable.
- 10°C to 60°C
- 10°C to 40°C
- 80 %, non condensing
- Measuring element IP54 (IEC 60529) or IP40 with active data output
- CE
- Plastic case
- TESA's calibration certificate
- Declaration of conformity
- Identification number
- Display lock
- RS232 opto-coupled, bidirectional

	mm	Elements	Measuring heads	mm	Setting rings	mm	Extensions	mm
COMPOSITION OF THE SETS:								
06130230	3,5 ÷ 6,5	06130010	06140020 06140021 06140022 06140023	3,5 ÷ 4 4 ÷ 4,5 4,5 ÷ 5,5 5,5 ÷ 6,5	00843200 00843201	4 5,5		
06130231	6 ÷ 12	06130011	06140024 06140025 06140026	6 ÷ 8 8 ÷ 10 10 ÷ 12	00840101 00840102	8 10	00840001	100
06130232	11 ÷ 20	06130011	06140027 06140028 06140029	11 ÷ 14 14 ÷ 17 17 ÷ 20	00840103 00840104	11 15	00840301	150
06130233	20 ÷ 40	06130011	06140030 06140031 06140032 06140033	20 ÷ 25 25 ÷ 30 30 ÷ 35 35 ÷ 40	00840106 00840107	25 35	00841100	150
06130234	40 ÷ 100	06130011	06140034 06140035 06140036 06140037 06140038 06140039	40 ÷ 50 50 ÷ 60 60 ÷ 70 70 ÷ 80 80 ÷ 90 90 ÷ 100	00840108 00840109 00840110	50 70 90	00841800	150
06130235	100 ÷ 300	06130012	06140040 06140041 06140042 06140043	100 ÷ 125 125 ÷ 150 150 ÷ 175 175 ÷ 200	00840112 00840113	125 175	00842600	150

Set available on request for extending the application range from 200 to 300 mm.



Cases for Sets of IMICRO Analogue

No	mm
00863035	3,5 ÷ 6,5
00863005	6 ÷ 12
00860008	11 ÷ 20
00860012	20 ÷ 40
00860017	40 ÷ 100
00863017	100 ÷ 200



Accessories for Both TESA IMICRO and TESA IMICRO CAPA μ SYSTEM – Extensions for Deep Hole Measurement

No	mm	A mm
00840001	6 ÷ 12	100
00840301	11 ÷ 20	150
00840302	11 ÷ 20	500
00841100	20 ÷ 40	150
00841101	20 ÷ 40	500
00841102	20 ÷ 40	1000
00841800	40 ÷ 100	150
00841801	40 ÷ 100	500
00841802	40 ÷ 100	1000
00842600	100 ÷ 300	150
00842601	100 ÷ 300	500
00842602	100 ÷ 300	1000



Cases for Single IMICRO Digital Instruments

No	mm
06160002	3,5 ÷ 40
06160003	40 ÷ 70



Centring Devices for TESA IMICRO

No	mm	A mm
00860001	40 ÷ 100	150
00862601	100 ÷ 200	200

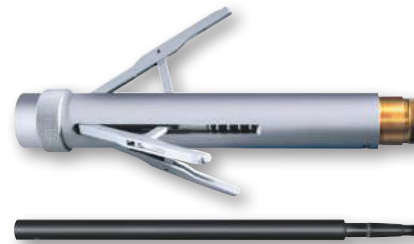

Cases for Sets of IMICRO Digital

No	mm
06160005	6 ÷ 12
06160006	3,5 ÷ 6,5 / 20 ÷ 40
06160007	40 ÷ 100



Cases for Single IMICRO Analogue Instruments

No	mm
00860007	11 ÷ 20
00860011	20 ÷ 40
00860015	40 ÷ 70
00860016	70 ÷ 100
00863016	100 ÷ 300



DIN 863 T4
(Style C1)



ROCH ALESOMETER with Analogue Indication, Metric

Bore gauges with 3-line contact. All ROCH ALESOMETER let you measure not only through bores, but also blind bores as well as centring shoulders, except for the models covering the application range 6 to 10 mm.



NFE 11-099.
Type 1 for models
6 to 10 mm or type 2
for all other models.



Measuring inserts
for application
range 6 to 10 mm:
steel, hardened to
550 HV 30.
10 to 300 mm:
tungsten carbide
tipped to HRC ≥ 70.



Wooden case



Calibration
certificate
upon request







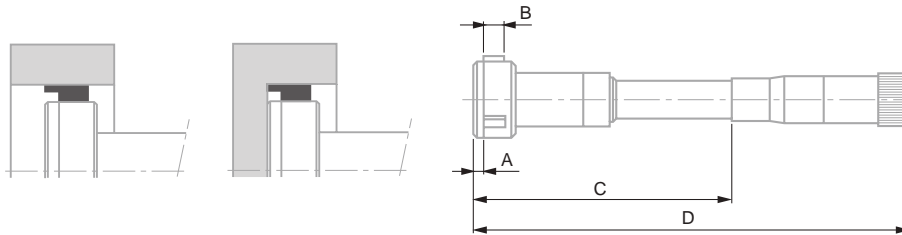

Declaration
of conformity



Identification
number



No							
	mm	mm	µm	A mm	B mm	C mm	D mm
0081725001	6 ÷ 8	0,001	4	1,2	3	54,5	107
0081725003	8 ÷ 10	0,001	4	1,2	3	54,5	107
0081725006	10 ÷ 12,5	0,001	4	0,3	6,5	64,5	117
0081725008	12,5 ÷ 15	0,001	4	0,3	6,5	64,5	117
0081725010	15 ÷ 17,5	0,001	4	0,3	6,8	64,5	117
0081725012	17,5 ÷ 20	0,001	4	0,3	6,8	64,5	117
0081725014	20 ÷ 25	0,001	4	0,3	8,5	70	122,5
0081725016	25 ÷ 30	0,001	4	0,3	8,5	70	122,5
0081725018	30 ÷ 35	0,001	4	0,3	8,5	70	122,5
0081725020	35 ÷ 40	0,001	4	0,3	8,5	70	122,5
0081725022	40 ÷ 50	0,001	4	0,3	14,5	108,7	188,7
0081725024	50 ÷ 60	0,001	5	0,3	14,5	108,7	188,7
0081725026	60 ÷ 70	0,001	5	0,3	14,5	108,7	188,7
0081725028	70 ÷ 85	0,001	5	0,3	14,5	126,7	206,7
0081725030	85 ÷ 100	0,001	5	0,3	14,5	126,7	206,7
0081725032	100 ÷ 125	0,01	7	0,3	30	153,7	233,5
0081725034	125 ÷ 150	0,01	7	0,3	30	153,7	233,5
0081725036	150 ÷ 175	0,01	8	0,3	30	153,7	233,5
0081725038	175 ÷ 200	0,01	8	0,3	30	153,7	233,5

Face A: Not applicable for models larger than 10 mm onwards, as the measuring inserts are too close to the micrometer front face.



ROCH ALESOMETER with Analogue Indication – Full Metric Sets

Bore gauges with 3-line contact. All ROCH ALESOMETER let you measure not only through bores, but also blind bores as well as centring shoulders, except for the models covering the application range 6 to 10 mm.



- NFE 11-099. Type 1 for models 6 to 10 mm or type 2 for all other models.
- Bore related tolerance: $\pm (3 \mu\text{m} + 10 \cdot 10^{-6} D) \mu\text{m}$
- Measuring inserts for application range 6 to 10 mm: steel, hardened to 550 HV 30. 10 to 300 mm: tungsten carbide tipped to HRC ≥ 70 .
- Wooden case
- Calibration certificate upon request
- Declaration of conformity
- Identification number
- D = nominal diameter in mm ($1 \mu\text{m} + 5 \cdot 10^{-6} D) \mu\text{m}$
- Extension: hardened steel, insulated body against hand warmth. Setting rings: steel, hardened to 60 HRC.

	mm	Single bore gauges	mm	Setting rings	mm	Extensions	A mm
COMPOSITION OF THE SETS:							
0081725063	6 ÷ 10	0081725001 0081725003	6 ÷ 8 8 ÷ 10	0211625101	8	0081625081	100
0081725066	10 ÷ 20	0081725006 0081725008 0081725010 0081725012	10 ÷ 12,5 12,5 ÷ 15 15 ÷ 17,5 17,5 ÷ 20	0211625102 0211625103	12,5 17,5	0081625082	100
0081725068	20 ÷ 40	0081725014 0081725016 0081725018 0081725020	20 ÷ 25 25 ÷ 30 30 ÷ 35 35 ÷ 40	0211625104 0211625105	25 35	0081625083	150
0081725070	40 ÷ 100	0081725022 0081725024 0081725026 0081725028 0081725030	40 ÷ 50 50 ÷ 60 60 ÷ 70 70 ÷ 85 85 ÷ 100	0211625106 0211625107 0211625109	45 60 85	0081625084	150

Extensions for Depth Increase for ROCH ALESOMETERS - Analogue Models



Identification number	mm	A mm
0081625081	6 ÷ 10	100
0081625082	10 ÷ 20	100
0081625083	20 ÷ 40	150
0081625084	40 ÷ 100	150

- Hardened steel. Insulated body against hand warmth.
- Declaration of conformity
- Identification number

TESA ALESOMETER CAPA μ SYSTEM with Digital Display

Fitted with a TESA patented capacitive measuring system. Bore gauges with 3-line contact. All TESA ALESOMETER are made to measure through and blind bores as well as short centring shoulders, except for the models covering the application range from 6 to 10 mm.

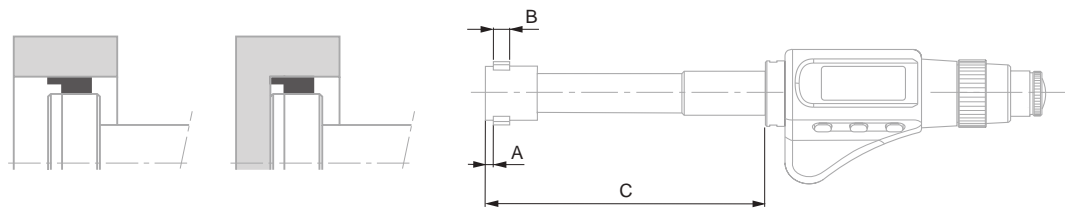

DIN 863 T4.
Style C1 for models 6 to 10 mm or style C2 for all other models.



0,001 mm /
0.00005 in



LCD, digit height
7 mm



Floating zero



Metric/inch
conversion



Measuring inserts
for application range
6 to 10 mm: steel,
hardened to
550 HV 30. 10 to 300:
tungsten carbide
tipped, HRC \geq 70.



3 V lithium battery



1 to 2 a
(\approx 2000 h/a)



Automatic shut
down after 10 min.
Display setting is
retained as long as
power supply
remains stable.



-10°C to 6°C



10°C to 40°C



80 %, non
condensing



For the measuring
element IP54
(IEC 60529) or
IP40 with active
data output



\leq 100 mm in
a plastic case
> 100 mm in
a wooden case



Inspection report
with a declaration
of conformity









Identification
number



Display lock



RS232
opto-coupled,
bidirectional

No							
	mm	in	μ m	μ m	A mm	B mm	C mm
06230051	6 \div 8	0.2362 \div 0.3150	4	4	1,2	3	55
06230052	8 \div 10	0.3150 \div 0.3970	4	4	1,2	3	55
06230023	10 \div 12,5	0.3970 \div 0.4921	4	4	0,3	6,5	65
06230024	12,5 \div 15	0.4921 \div 0.5905	4	4	0,3	6,5	65
06230025	15 \div 17,5	0.5905 \div 0.6890	4	4	0,3	6,8	65
06230026	17,5 \div 20	0.6890 \div 0.7874	4	4	0,3	6,8	95
06230027	20 \div 25	0.7874 \div 0.9843	4	4	0,3	8,5	100
06230028	25 \div 30	0.9843 \div 1.1811	4	4	0,3	8,5	100
06230029	30 \div 35	1.1811 \div 1.3780	4	4	0,3	8,5	100
06230030	35 \div 40	1.3780 \div 1.5748	4	4	0,3	8,5	100
06230031	40 \div 50	1.5748 \div 1.9685	4	4	0,3	14,5	140
06230032	50 \div 60	1.9685 \div 2.3622	5	5	0,3	14,5	140
06230033	60 \div 70	2.3622 \div 2.7560	5	5	0,3	14,5	140
06230034	70 \div 85	2.7560 \div 3.3465	5	5	0,3	14,5	140
06230035	85 \div 100	3.3465 \div 3.9370	5	5	0,3	14,5	140
06230036	100 \div 125	3.9370 \div 4.9212	6	6	0,3	30	175
06230037	125 \div 150	4.9212 \div 5.9055	6	6	0,3	30	175
06230038	150 \div 175	5.9055 \div 6.8897	7	7	0,3	30	175
06230039	175 \div 200	6.8897 \div 7.8740	7	7	0,3	30	175

OPTIONAL ACCESSORY

01961000 1 Lithium battery 3V, CR2032

Face A: Not applicable for models larger than 10 mm onwards, as the measuring inserts are too close to the micrometer front face.



TESA ALESOMETER CAPA μ SYSTEM with Digital Display - Partial Sets and Components

Fitted with TESA patented capacitive measuring system. Models that cover the application range from 6 to 10 mm can only measure through bores – All other partial sets also allow blind bores as well as short centring shoulders to be inspected.



DIN 863 T4.
Style C1 for models 6 to 10 mm or C2 for all other models



0,001 mm / 0.00005 in
Measuring inserts for application range 6 to 10 mm: steel, hardened to 550 HV 30. 10 to 300: tungsten carbide tipped to HRC \geq 70.



\leq 100 m in a plastic case,
 $>$ 100 m in a wooden case
Inspection report with a declaration of conformity



Identification number

No	mm	No	Measuring heads	mm	No	Connectors	No	Measuring elements	No	Setting rings	mm	No	Storage case
COMPOSITION OF THE SETS:													
06230100	6 ÷ 10	0081720351	6 ÷ 8	0081620491	06230020	0211625101	8	06260001					
		0081720353	8 ÷ 10										
06230110	10 ÷ 20	0081720356	10 ÷ 12,5	0081620492	06230020	0211625102	12,5	06260001					
		0081720358	12,5 ÷ 15			0211625103	17,5						
		0081720360	15 ÷ 17,5										
		0081720362	17,5 ÷ 20										
06230111	20 ÷ 40	0081720364	20 ÷ 25	0081620493	06230020	0211625104	25	06260001					
		0081720366	25 ÷ 30			0211625105	35						
		0081720368	30 ÷ 35										
		0081720370	35 ÷ 40										
06230112	40 ÷ 100	0081720372	40 ÷ 50	0081620494	06230020	0211625106	45	0081629525					
		0081720374	50 ÷ 60			0211625107	60						
		0081720376	60 ÷ 70			0211625109	85						
		0081720378	70 ÷ 85										
		0081720380	85 ÷ 100										

Set available on request for extending the application range from 100 to 300 mm.



Models from 10 to 100 mm:
DIN 863 T4
(Style C2)
NFE 11-099



Max. perm. error for models covering the application ranges from
5 to 40 mm = 3 μ m
40 to 100 mm = 4 μ m
100 to 200 mm = 5 μ m



Repeatability limit for models covering the application ranges from
5 to 40 mm = 3 μ m
40 to 100 mm = 4 μ m
100 to 200 mm = 5 μ m



Measuring bolts on models from 5 to 100 mm:
hardened steel.
100 to 200 mm:
tungsten carbide tipped



Protective case or carrying case



Inspection report with a declaration of conformity



Identification number



Models from 5 to 100 mm:
0,002 mm
Models 100 to 200 mm with vernier reading: 0,01 mm



ETALON INTALOMETER 531

Made to check through holes, blind bores and short centring shoulders. All models covering the application range up to 100 mm have sloped bolts extending beyond the front face of the measuring head.

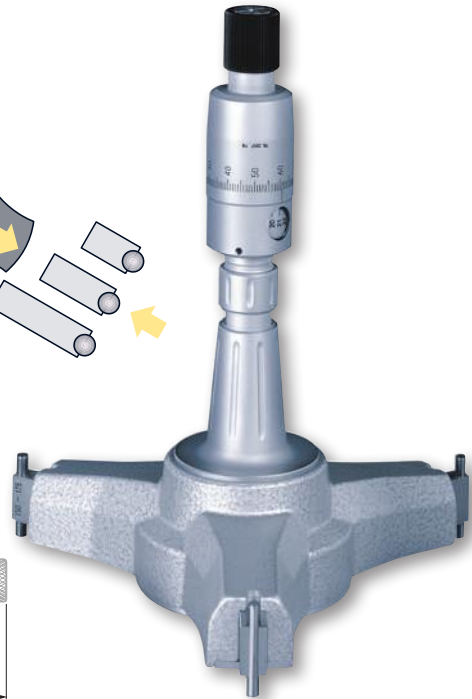
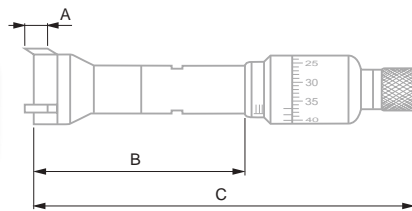
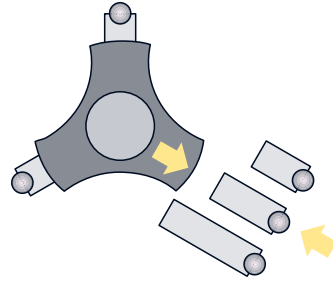

No					
	mm		A mm	B mm	C mm
078112356	5 ÷ 6	2 x 180°	3	≥ 32	≤ 109
078112357	6 ÷ 7	2 x 180°	3	≥ 33	≤ 111
078112358	7 ÷ 8,5	2 x 180°	4	≥ 60	≤ 130
078112359	8,5 ÷ 10	2 x 180°	4	≥ 72	≤ 133
078112360	10 ÷ 12,5	3 x 120°	3	≥ 60	≤ 118
078112361	12,5 ÷ 15	3 x 120°	3	≥ 63	≤ 120
078112362	15 ÷ 17,5	3 x 120°	3	≥ 65	≤ 122
078112363	17,5 ÷ 20	3 x 120°	3	≥ 68	≤ 125
078112364	20 ÷ 25	90°-135°-135°	7	≥ 75	≤ 132
078112365	25 ÷ 30	90°-135°-135°	7	≥ 90	≤ 138
078112366	30 ÷ 35	90°-135°-135°	7	≥ 90	≤ 142
078112367	35 ÷ 40	90°-135°-135°	7	≥ 90	≤ 148
078112368	40 ÷ 45	90°-135°-135°	10,5	≥ 110	≤ 167
078112369	45 ÷ 50	90°-135°-135°	10,5	≥ 113	≤ 170
078112370	50 ÷ 60	90°-135°-135°	15	≥ 123	≤ 187
078112371	60 ÷ 70	90°-135°-135°	15	≥ 130	≤ 193
078112372	70 ÷ 85	90°-135°-135°	15	≥ 145	≤ 213
078112373	85 ÷ 100	90°-135°-135°	15	≥ 155	≤ 224
078110733	100 ÷ 125	3 x 120°	27	≥ 105	≤ 194
078110735	125 ÷ 150	3 x 120°	27	≥ 105	≤ 194
078110737	150 ÷ 175	3 x 120°	27	≥ 105	≤ 194
078110739	175 ÷ 200	3 x 120°	27	≥ 105	≤ 194

Measuring range up to 300 mm available upon request.



ETALON INTALOMETER 531, Metric Sets

Made to check through holes, blind bores and short centring shoulders. All models covering the application range up to 100 mm have sloped bolts extending beyond the front face of the measuring head.



Models from 10 to 100mm: DIN 863 T4 (Style C2) NFE 11-099



Max. perm. error for models covering the application ranges from 5 to 40 mm = 3 µm 40 to 100 mm = 4 µm 100 to 200 mm = 5 µm



Repeatability limit for models covering the application ranges from 5 to 40 mm = 3 µm 40 to 100 mm = 4 µm 100 to 200 mm = 5 µm



Measuring bolts on models from 5 to 100 mm: hardened steel. 100 to 200 mm: tungsten carbide tipped.



Protective case or carrying case



Inspection report with a declaration of conformity



Identification number



Models from 5 to 100 mm = 0,002 mm on vernier, 100 to 200 mm = 0,01 mm

No	mm	No	Isolated instruments	mm	No	Setting rings	mm	No	Extensions	mm
COMPOSITION OF THE SETS:										
078110592	5 ÷ 10	078112356		5 ÷ 6	00840114	6		078103613	100	
		078112357		6 ÷ 7	00840115	8,5				
		078112358		7 ÷ 8,5						
		078112359		8,5 ÷ 10						
078110594	10 ÷ 20	078112360		10 ÷ 12,5	00840116	12,5		078103621	150	
		078112361		12,5 ÷ 15	00840117	17,5				
		078112362		15 ÷ 17,5						
		078112363		17,5 ÷ 20						
078110596	20 ÷ 40	078112364		20 ÷ 25	00840106	25		078103624	150	
		078112365		25 ÷ 30	00840107	35				
		078112366		30 ÷ 35						
		078112367		35 ÷ 40						
078110598	40 ÷ 100	078112368		40 ÷ 45	00843230	45		078104940	150	
		078112369		45 ÷ 50	00843239	60				
		078112370		50 ÷ 60	00840118	85				
		078112371		60 ÷ 70						
		078112372		70 ÷ 85						
		078112373		85 ÷ 100						



DIN 863 T4
(Style C2)
NFE 11-099

000 0,01 mm

Tungsten carbide
tipped measuring
bolts and cone

Shipping box

Inspection report
with a declaration
of conformity

No
NO Identification
number

0,002 mm

Supplied with 1 heat
insulating sleeve
(No. 00940020),
2 keys (No. 00940001),
1 screwdriver
(No. 00862801).

TESA TRI-O-BOR

Self-centring and self-aligning internal micrometers with 3-line contact with the part being inspected.

These micrometers measure trough holes, blind bores and short centring shoulders.

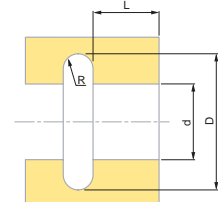
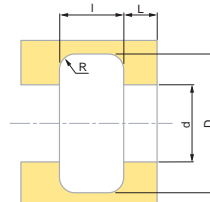
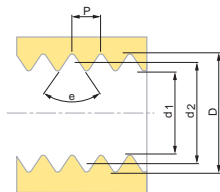
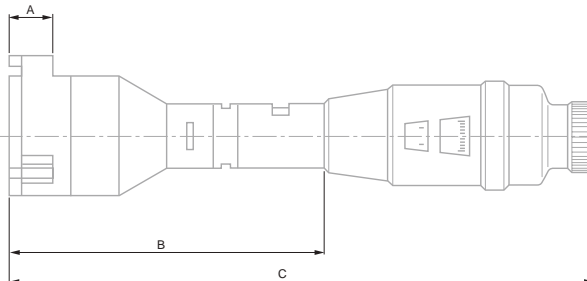

No						
	mm	µm	µm	A mm	B mm	C mm
00910005	5 ÷ 20	4	4	6	≥ 66	≤ 132
00910006	20 ÷ 25	4	4	6	≥ 66	≤ 132
00910007	25 ÷ 30	4	4	6	≥ 66	≤ 132
00910405	30 ÷ 40	4	4	10	≥ 70	≤ 138
00910406	40 ÷ 50	4	4	10	≥ 70	≤ 138
00910407	50 ÷ 60	5	5	10	≥ 70	≤ 138
00910705	60 ÷ 70	5	5	18	≥ 78	≤ 147
00910706	70 ÷ 80	5	5	18	≥ 78	≤ 147
00910707	80 ÷ 90	5	5	18	≥ 78	≤ 147
00911105	90 ÷ 100	5	5	18	≥ 78	≤ 147
00911106	100 ÷ 110	6	6	18	≥ 78	≤ 147
00911107	110 ÷ 120	6	6	18	≥ 78	≤ 147

OPTIONAL ACCESSORY

00940000 Extension of 150 mm for TESA TRI-O-BOR



TESA TRI-O-BOR, Full Sets

Self-centring and self-aligning internal micrometers with 3-line contact with the part being inspected.

These micrometers measure through holes, blind bores and short centring shoulders.



- DIN 863 T4 (Style 2) NFE 11-099
- 0,01 mm
- Tungsten carbide tipped measuring bolts and cone
- Protective case or carrying case
- Inspection report with a declaration of conformity
- Identification number
- 0,002 mm
- Supplied with 1 heat insulating sleeve No 00940020, 2 key No 00940001, 1 screwdriver No 00862801

		mm	Single micrometers	mm	Setting rings	mm	Extensions	mm
COMPOSITION OF THE SETS:								
00910004	BSC	15 ÷ 30	00910005 00910006 00910007	15 ÷ 20 20 ÷ 25 25 ÷ 30	00840104 00840106	15 25	00940000	150
00910404	BSD	30 ÷ 60	00910405 00910406 00910407	30 ÷ 40 40 ÷ 50 50 ÷ 60	00840107 00840108	35 50	00940000	150
00910704	BSF	60 ÷ 90	00910705 00910706 00910707	60 ÷ 70 70 ÷ 80 80 ÷ 90	00840109 00840110	70 90	00940000	150
00911104	BSG	90 ÷ 120	00911105 00911106 00911107	90 ÷ 100 100 ÷ 110 110 ÷ 120	00840110 00840111	90 110	00940000	150

Extension for Depth Increase TESA TRI-O-BOR



00940000	mm 150



Shipping box

No. Identification number

SETTING STANDARDS FOR INTERNAL MICROMETERS

TESA Setting Rings and Setting Masters

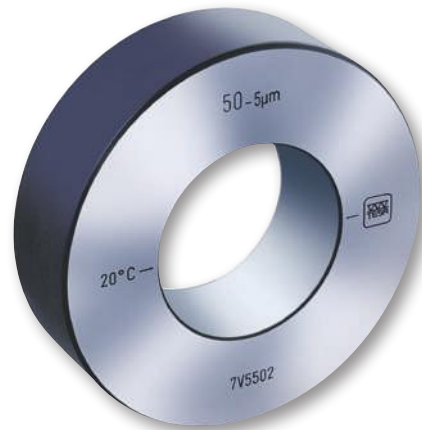

Setting ring 50 mm

Setting standard 225-275 mm



No.	∅	d	µm**
	mm	µm*	µm**
00843200	4	1,5	1,5
00843201	5,5	1,5	1,5
00840114	6	1,5	1,5
00840101	8	1,5	1,5
00840115	8,5	1,5	1,5
00840102	10	1,5	1,5
00840103	11	1,5	1,5
00840116	12,5	1,5	1,5
00840104	15	1,5	1,5
00840105	17	1,5	1,5
00840117	17,5	1,5	1,5
00840106	25	1,5	1,5
00840107	35	2	2
00843230	45	2	2
00840108	50	2	2
00843239	60	2	2
00840109	70	2	2
00840118	85	2	2
00840110	90	2	2
00840111	110	2,5	2,5
00840112	125	2,5	2,5
00840113	175	2,5	4
00843101	225, 275	-	6

* Making no allowance for a rim of 1 mm.

** All listed values are determined through a 2-point measurement taken at half-height of the setting ring. The measuring direction is marked with 2 strokes. The measured actual dimension is engraved on every setting master.





Measuring Instruments for Large Dimensions



TESA – THE SPECIALISTS FOR LONG LENGTHS

For large dimensions from 250 mm up to several meters, TESA offers various types of measuring instruments that have long proven their value in practical use.

Whatever the sizes, from a simple distance between two surfaces parallel to one another measurement is always a challenge. Apart from the usual influences, which are proportional to the size whilst adding to your contributions in the uncertainty budget, those due to gravity play a key role in distortion.

Large sizes in mechanical engineering generally mean dimensions in excess of 500 mm. Various measurement procedures are brought into play, using such items as large internal and external micrometers with two-point contact, periphery tapes (for outside diameters), V-bases, rotating measuring disks (rolling-contact) optical systems (triangulation with theodolite), fixed gauges (inside caliper gauges), gauge blocks combinations or adjustable telescopic gauges.

There are other methods that often call for very simple techniques, such as fixed gauges (caliper gauges), combinations of gauge blocks, or even adjustable telescopic gauges.

Here's an example of a proportional relationship. With a bore of $\varnothing 1200$ H7, the tolerance area matches 0,1 mm. Reducing both values by a factor of 100 would give a manufacturing tolerance as low as $1 \mu\text{m}$. Of course, things are not as simple, but this example gives some ideas about the proportions.



TESA UNITEST Internal Micrometer

Measures internal dimensions in the micrometer's axis with 2-point contact with the workpiece to be checked – Optional accessories are available for inspecting centring shoulders and blind bores along with auxiliary means for external measuring.

Extensions with built-in gauge rods can be mounted on the measuring element, thus allowing any dimension within the application range to be measured, directly.



- DIN 863 T4 (Style B)
- Micrometer: 25 mm
- Dial gauge: ± 0,22 mm
- Micrometer and dial gauge: 0,01 mm
- Micrometer: 0,1 mm
- 8 µm
- Measuring bolts: Spherical and for measuring in the micrometer axis. All inserts are interchangeable
- Extension: 1 spherical and 1 flat measuring face
- 0,5 mm
- Tungsten carbide tipped
- 0,7 to 1N
- Extension: 26 mm dia. steel tube with snap-ring system. Also with built in gauge rods.
- Wooden case
- Setting standard with identification number
- Calibration certificate:
 - per setting standard
 - per measuring element
 - per extension
- Declaration of conformity



No	=				
01110700	UNITEST (SET)	mm	Internal dimensions 200 ÷ 1400		
CONSISTING OF:					
No	=				
01110901	Measuring head	mm	mm	µm	Internal dimensions 200 ÷ 225
01141001	Setting gauge	Internal / external dimensions		mm	200
01110801	Extension			mm	25
01110802	Extension			mm	50
01110804	Extension			mm	100
01110808	Extension			mm	200
01110812	Extension			mm	300
01110820	Extension			mm	500
01160901	Screwdriver				
01162302	Case for Unitest				
OPTIONAL ACCESSORIES:					
01160701	Pair of tungsten carbide tipped measuring bolts for blind bores				
01162301	Auxiliary elements for external measurement			mm	Measuring depth: ≤ 10
01140801	Suspension device, complete			mm	Measuring depth: ≤ 100



TESA UNIMASTER Universal Measuring Instrument

TESA UNIMASTER Universal Measuring Instrument provides the features necessary for direct measurement of specially large internal and external dimensions. TESA UNIMASTER is similar to internal micrometers with two-point contact with the workpiece being measured. Measures any dimension within the extended application range directly by simply adding the needed extensions with built-in gauge blocks to the measuring element.

Accurate, robust and easy-to-handle – Can be used either vertically or horizontally with a constant measuring force – Incorporates a lever-type dial test indicator that clearly shows the culmination point – Ensures stable measuring owing to both a negligible deflection and thermal protection on each extension.

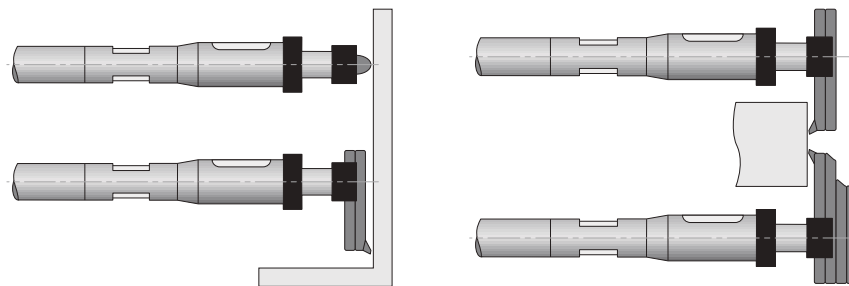

- DIN 863 T4 (Style B)
- Micrometer: 25 mm
- Dial test indicator: $\pm 0,4$ mm
- Micrometer and dial test indicator: 0,01 mm
- 5 μ m
- One spherical and one flat measuring faces
- 1 mm Tungsten carbide tipped
- 15 to 20 N measuring force reversible between internal and external directions
- Measuring bolts supplied in pairs:
 - No. 01110203 for internal measuring in the micrometer axis.
 - No. 01110205 for internal/external measuring, meas. depth up to 60 mm from the lower edge of the micrometer.
 - No. 01110208, extra-rigid for external measuring, meas. depth up to 75 mm from the lower edge of the micrometer.
- Extension: 38 mm dia. diameter steel tube with snap ring system. Built-in gauge rod.
- Mobile ball-bearing anvil under spring pressure.
- Wooden case
- Measuring element and setting standard with identification number
- Calibration certificate:
 - per setting standard
 - per measuring element
 - per extension
- Declaration of conformity



No	=	mm	mm			
01110000	TESA UNIMASTER metric full	Int. dim. 250 ÷ 1475*	Ext. dim. 225 ÷ 1450*			
CONSISTING OF:						
No	=	mm	mm	mm	mm	µm
01110300	Measuring element UNIMASTER	Int. dim. 250 ÷ 275	Ext. dim. 225 ÷ 250			
01110203	Set measuring arms interior dimensions					
01110205	Set measuring arms for interior and exterior dimensions, length 75mm			75		
01110208	Set measuring arms for interior and exterior dimensions, length 100mm			100		
01110501	Setting gauge			Int. dim.: 250	Ext. dim. : 225	
01110101	Extension			25		0,7
01110102	Extension			50		1
01110103	Extension			75		1,2
01110104	Extension			100		1,5
01110105	Extension			125		1,5
01110106	Extension			150		2
01110112	Extension			300		3,5
01110118	Extension			450		4,5
01110124	Extension			600		6,5
01130001	Special screwdriver					
01110401	Set of suspension accessories (4 brackets together with 4 clamps)					
01112401	Wooden case for complet set					
OPTIONAL ACCESSORIES:						
01110140	Extension 1000 mm			1000		10
01162001	Anvils for internal/external dimensions and throats			Measuring depth: ≤ 20	Tungsten carbide inserts: Ø 4 x 7	
01160001	Roller (2 items are needed)					

*Using 3 extensions at the very most.

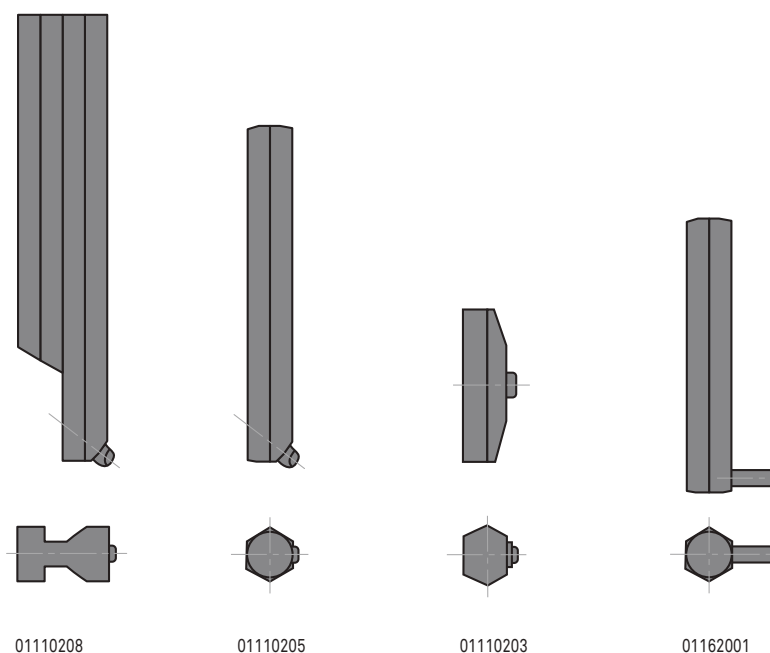

01110208

01110205

01110203

01162001



TESA INOTEST Comparative Measuring Instrument

Allows for comparative measurement of large internal or external dimensions. Consists of a measuring element with interchangeable inserts as well as a set of extensions. Since there is no material measure, the indication is set using a separate standard that can either be a gauge block, setting ring or horizontal measuring bench.

Measuring inserts for inspection in the tool axis, or offset inserts – Vertical or horizontal position of use – Integrated dial gauge to show the culmination point – Constant measuring force – Extensions with heat insulating grip.

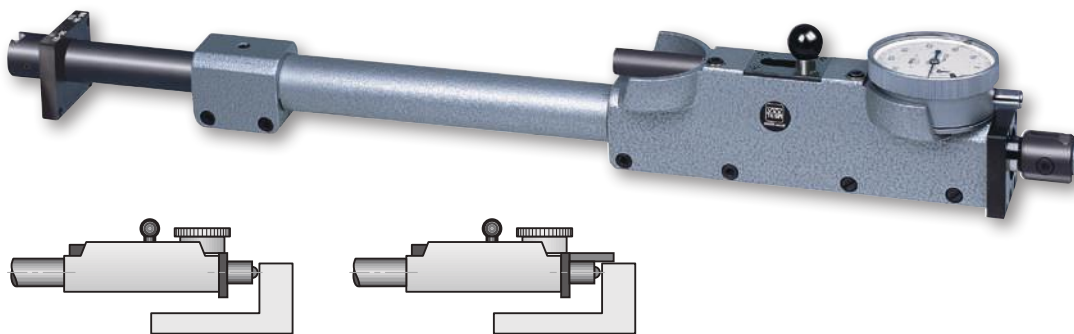
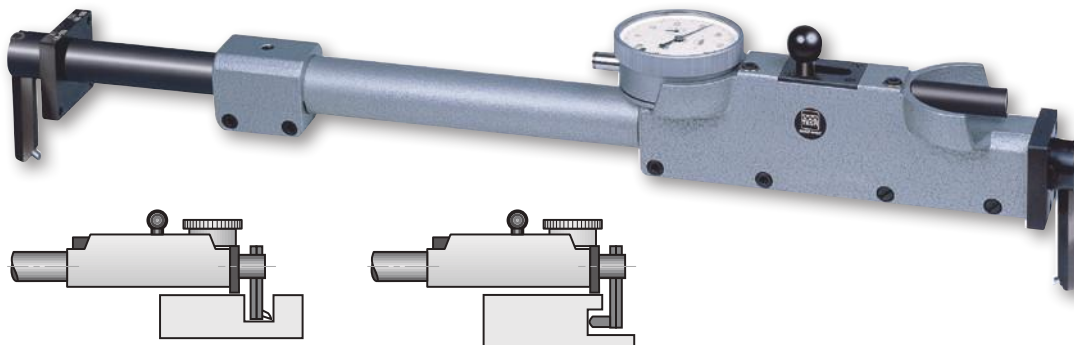
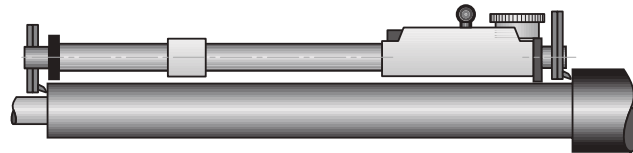

10 mm



0,01 mm



Measuring bold and extension: Tungsten carbide tipped



4 tp 7N. Reversible probing direction to allow both internal and external measuring.



Watertight dial gauge No. 01470104 and 01480100



Measuring bolts supplied in pairs:
 • No. 01131901 for internal measuring in the instrument axis.
 • No. 01131902 for internal/external measurement, measuring depth up to 30 mm from the lower edge of the tool



Extension: 25 mm dia. steel tube. 19 mm dia telescopic tube that can be clamped



Mobile ball-bearing anvil under spring pressure, 10 mm travel



For additional technical data: see chapter Indicators



Plastic case



Dial gauge with serial number



Declaration of conformity



Dial gauge with inspection report





No	=		
01111900	TESA INOTEST complete set	mm Int. dim. 275 ÷ 1025	mm Ext. dim. 250 ÷ 1010
CONSISTING OF:			
No	=		
01112301	Measuring element INOTEST		
01131901	Pair of inserts for internal measuring		
01131902	Pair of inserts for internal and external measuring, length 60 mm	60	
01132001	Set of 4 mounting rods	∅ 7 x 40	
00160101	3 insulating grips (reference code is for 1 item)		
01112001	Extension 250 ÷ 310 mm	Int. dim.: 275 ÷ 335	Ext. dim.: 250 ÷ 310
01112002	Extension 300 ÷ 410 mm	Int. dim.: 325 ÷ 435	Ext. dim.: 300 ÷ 410
01112003	Extension 400 ÷ 610 mm	Int. dim.: 425 ÷ 635	Ext. dim.: 3400 ÷ 610
01112004	Extension 600 ÷ 1010 mm	Int. dim.: 625 ÷ 1035	Ext. dim.: 600 ÷ 1010
01162303	Case INOTEST		
OPTIONAL ACCESSORIES:			
01141901	Extension 500 mm	500	
01141902	Extension 1000 mm	1000	
01162001	Carbide measuring inserts for throats	Measuring depth: ≤ 20	Tungsten carbide inserts: ∅ 4 x 7
01161900	Device for small dimensions, Inotest	Int. dim. 35 ÷ 280	Ext. dim. 15 ÷ 255



ETALON 532 Internal Micrometer

This micrometer is designed for measurements with 2-point contact.

Extensions with built-in gauge rods can be used to increase the measuring range – Stiff screw coupling.



Full set:			072109101	072109107	072109108	072109117	072109128
		mm	50 ÷ 170	50 ÷ 290	50 ÷ 530	50 ÷ 1010	50 ÷ 1510

COMPOSED BY:

		mm	mm	µm					
072103576	Micrometrical element	50 ÷ 65		3	•	•	•	•	•
072103585	Extention		15	1,5	•	•	•	•	•
072105462	Extention		30	1,5	•	•	•	•	•
072109030	Extention		60	2	•	•	•	•	•
072103586	Extention		120	2		•	•	•	•
072109055	Extention		240	3			•	•	•
072109066	Extention		480	3,5				•	•
072109089	Extention		500	3,5					•

- Factory standard
- 15 mm
- 0,01 mm
- Spheric (R = 15 mm)
- 29 mm
- 0,5 mm
- Tungsten carbide tipped
- Reference gauge rods
- Wooden case
- Declaration of conformity

ROCH Metric Periphery Tapes

Steel tapes with a dual graduation for measuring external circumferences and diameters of cylindrical parts on machines and other fittings – Suitable for malleable parts such as plastic tubing – Used for inspecting tanks or boilers – Also designed for checking steel or concrete pipes, rims, tires etc.

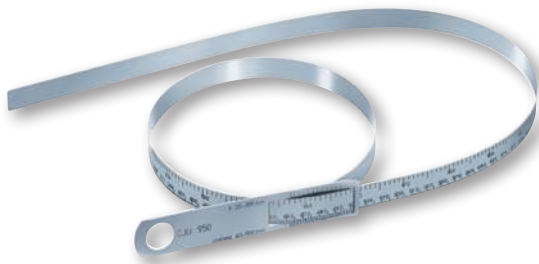

	Diameter, mm	Circumference, mm	mm
0951750222	20 ÷ 30	60 ÷ 950	0,15
0951750223	300 ÷ 700	940 ÷ 2200	0,20
0951750224	700 ÷ 1100	2190 ÷ 3460	0,20
0951750225	1100 ÷ 1500	3450 ÷ 4720	0,25

- Factory standard
- See table
- 0,1 mm
- 16 x 0,2 mm type section
- Steel band
- Shipping packaging
- Declaration of conformity

Dial gauges – Electronic and Analogue

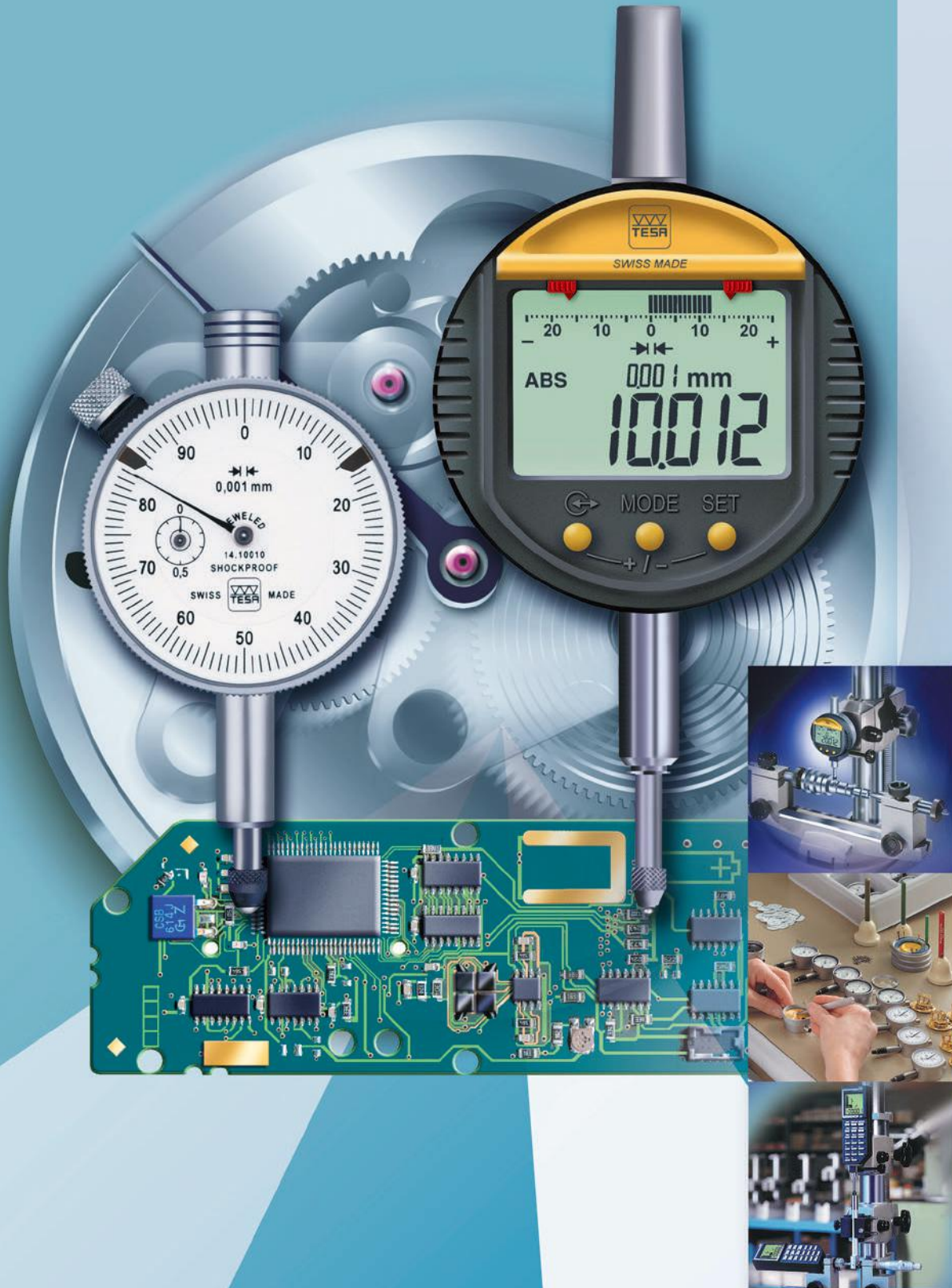

EASY-TO-USE AND VERSATILE

For more than 50 years we have been producing and distributing a wide range of easy-to-use and versatile dial gauges. Our experience allows us to offer a wide choice of different models.

- Electronic indicators with combined analogue/digital display using the most up-to-date technology.
- Mechanical dial gauges equipped with high-precision movements and double-action shockproof mechanisms. Measuring spans up to 100 mm.

CHOICE OF DIAL GAUGE OR ELECTRONIC INDICATOR

- Digital indication provides error-free reading of the measured value. There is no need to read fractions of scale divisions.
- Analogue indication offers the advantage of being able to smoothly adjust the increase or decrease of the dimension to be measured on the workpiece. This type of indication is best suited for dynamic measurements such as determining axial and radial runout errors.
- Electronic indicators provide many additional functions compared to the mechanical models. For more information, refer to the section on electronic indicators.
- The inspection of axial and radial runout errors frequently requires the use of instruments with the lowest hysteresis characteristic. Our electronic indicators, precision dial gauges and dial test indicators meet this requirement.
- In order to significantly reduce the effect of systematic errors, it is recommended to carry out comparative measurements. Only deviations from the nominal dimension will be displayed. High precision, small range electronic indicators are the ideal instruments for these types of measurements.
- These same instruments also enable avoiding major errors in reading millimetres.

STANDARDS AND DEFINITIONS

The international ISO 463:2006 standard replaces national standards dealing with mechanical dial gauges. All the same, new definitions and standard requirements pertaining to measuring procedures, although valid, imply changes in design and metrological characteristics, which cannot be entirely indicated in this catalogue. This standard, is defined in the matrix "Product Specification (GPS) - dimensional measuring instruments". It only defines the requirements for the most important characteristics.

Therefore, all tolerance limits indicated in this catalogue which refer to metrological characteristics are based on our own internal standards.

Electronic indicators and short range precision indicators. Definitions used in this section:



Total permissible error in 1 measuring direction over the entire measuring range within the partial measuring range

in the 2 measuring directions



Repeatability limit



Max. hysteresis

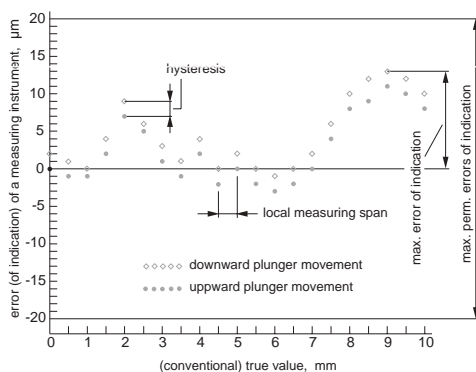

Mechanical dial gauges.

Definitions used in this section for the maximum permissible errors of a metrological characteristic (MPE):



Deviation span (error of indication within the measuring range)

Deviation span (error of indication) within the partial measuring range

Total deviation span (error of indication within the measuring range)



Repeatability limit (reliability) of indication



Hysteresis of indication

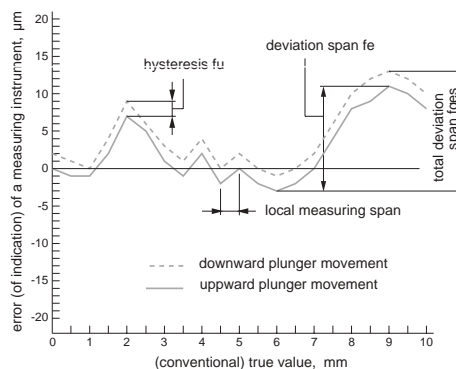

TESA DIGICO 205 / 305

- Dual LC Display, digital and analogue.
- Mechanical tolerance markers.
- Dimensions according to DIN 878.

Main functions

ON/Auto OFF - Data output - Counting sense reversal - Keypad lock.

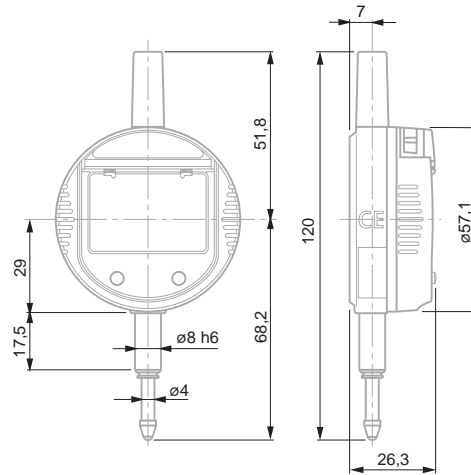

- Resolution 0,01 mm = ±0,25 mm
Resolution to 0,001 mm = ±0,025 mm
- 6-decade LC display field, plus minus sign
- Digit size 10 x 5 mm (H x L)
- Combined analogue and numerical display
- Glass scale with incremental divisions, capacitive
- MI or MIE type: metric/inch conversion
- ≤ 2 N
- ≤ 2 m/s
- Full-metal housing with front face in polyamide. Stainless steel plunger. M2,5 mounting thread for measuring insert.
- RS232, opto-coupled
- 3V lithium battery type CR2032
- 1 year to 2 years
- 10°C to 40°C
- 10°C to 60°C
- ~80 %
- EN 50081-1
EN 50082-1
- 150 g
- Transport case with 1 lithium battery 01961000
- Identification number
- Inspection report with declaration of conformity

			mm	in	mm	in	µm	µm
01930230	DIGICO 205 MI		12,5	0.5	0,01	0.0005	20	10
01930231	DIGICO 305 MI		12,5	0.5	0,001	0.00005	8	2



TESA DIGICO 400 / 500

- Measuring modes ABS/REL.
- Dual LC Display, digital and analogue
- Rotation through 270° of display and key functions.
- Mechanical tolerance marks.
- Graphical display of tolerance limits.

Measuring functions and modes

ON - Auto OFF - PRESET mode - Tolerance mode - Data output - Counting sense reversal - Keypad lock - Metric/Inch units - Full RESET.

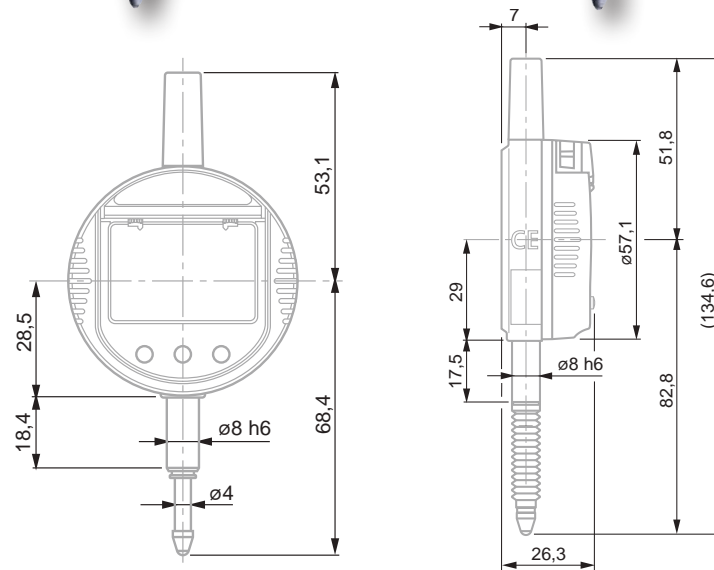

- Resolution 0,01 mm = ±0,25 mm Resolution 0,001 mm = ±0,025 mm
- 6-decade LC display field plus minus sign
- Digit size 10 x 5 (H x L)
- Combined analogue and numerical display
- Glass scale with incremental divisions, capacitive
- Conversion mm/in
- Measuring force: < 2 N
- ≤ 2 m/s
- Full-metal housing, front face in polyamide, Stainless steel plunger, M2,5 mounting thread for measuring insert.
- RS232, opto-coupled
- 3V lithium battery, type CR2032
- 1 year to 2 years
- 10°C to 40°C
- 10°C to 60°C
- 80 %
- EN 50081-1 EN 50082-1
- Shipping case including one lithium battery 01961000
- Identification number
- Inspection report with declaration of conformity

No	=								
01930241	DIGICO 410 MI	25	1	0,01	0.0005	20	10	-	162
01930255	DIGICO 505 MIP, protected	12,5	0.5	0,001	0.00005	4	2	IP62	150



Resolution 0,01 mm
= ± 0,25 mm Resolution
0,001 mm =
± 0,025 mm

6-decade LC display
field plus minus sign

Digit size 10 x 5 mm
(H x L)

Combined analogue
and numerical
display

Glass scale with in-
cremental divisions,
capacitive

Conversion mm/in

Measuring force:
< 2 N

≤ 2 m/s

Full-metal housing
with front face in
polyamide. Stainless
steel plunger.
M2,5 mounting
thread for mea-
suring insert.

RS232,
opto-coupled

3V lithium battery,
type CR2032

1 year to 2 years

10°C to 40°C

-10°C to 60°C

80 %

EN 50081-1
EN 50082-1

Transport case with
1 lithium battery
01961000

Identification
number

Inspection report
with eclaration of
conformity

TESA DIGICO 600

- Measuring modes ABS/REL.
- Dual LC Display.
- Display rotation through 270°. Same goes for the key functions.
- Mechanical tolerance marks.
- Graphical display of tolerance limits.

Measuring functions and modes

ON – Auto OFF – PRESET mode – Tolerance mode – Measured value storage

- Max • Min • Max-Min (TIR) – Data output – Counting sense reversal – Keypad lock – Metric/Inch units – Full RESET.

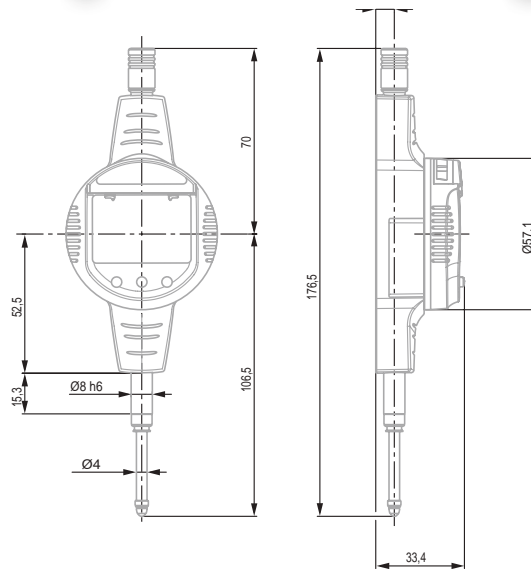

No	=	mm	in	mm	in	µm	µm	g
01930256	DIGICO 605 MI	12,5	0,5	0,001	0.00005	4	2	150
01930257	DIGICO 610 MI	25	1	0,001	0.00005	5	2	162



TESA DIGICO 705

For use with 2-point contact bore gauges. Allows setting of the dial gauge to the smallest setting ring value.

- Same functions as DIGICO 600.



- Resolution to 0,01 mm = ± 0,25 mm
Resolution 0,001 mm = ± 0,025 mm
- 6-decade LC display field, plus minus sign
- Digit size 10 x 5 mm (H x L)
- Combined analogue and numerical display
- Glass scale with incremental divisions, capacitive
- Conversion mm/in
- Measuring force < 2 N
- ≤ 2 m/s
- Full-metal housing with front face in polyamide. Stainless steel plunger, M2,5 mounting thread for the measuring insert.

01930258	DIGICO 705 MI	12,5	0.5	0,001	0.00005	4	2	150

- RS232, opto-coupled
- 3V lithium battery, type CR2032
- 1 to 2 years
- 10°C to 40°C
- 10°C to 60°C
- 80 %
- EN 50081-1 EN 50082-1
- Transport case with 1 lithium battery 01961000
- Identification number
- Inspection report with declaration of conformity

Accessories for TESA DIGICO 200 – 700

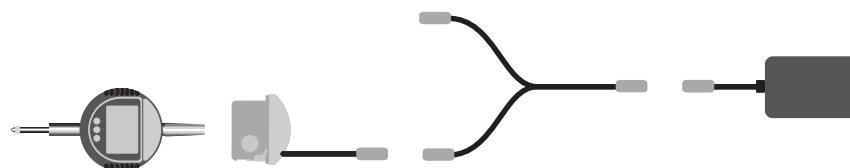

01962002		External power supply
01961000		Lithium battery, 3V, CR2032
04761054		Battery charger 100 ÷ 200 VAC / 50 ÷ 60 Hz, 6,6 Vdc, 750 mAh supplied without power cable
04761055		Cable EU for charger 0471054
04761056		Power cable US for charger 0471054

- Measuring inserts, see chapter "Measuring inserts for dial gauges, axial probes and other hand tools".
- Backs and retraction devices, see chapter "Devices for plunger retraction" and "Backs for Dial Gauges".
- Connectivity, see corresponding chapter.

- According to selected tolerances
- 30,4 mm (DIGICO 1) or 60,4 mm (DIGICO 2)
- 40 mm scale length
- 25 divisions
- According to selected tolerances
- 6 decades plus minus sign
- See table
- 9 x 4,5 mm digit size (H x W)
- LC display with backlight
- Incremental glass scale
- Metric/inch conversion
- DIGICO 1: 2 µm
DIGICO 2: 3 µm
- 1 µm
- 1 µm
- See table for measuring forces
- DIGICO 1: max. 1 m/s
DIGICO 2: max. 2 m/s
- Plunger guided on a plain bearing M2,5 mounting thread for measuring insert.
- RS232
- 3,6 V lithium battery or mains adapter
- ≈ 1000 h with lithium battery
- 0,002%/°C
- 10°C to 40°C
- 10°C to 50°C
- DIGICO case in standard execution: IP54 (IEC 60529)
-
- 290 g (DIGICO 1)
310 g (DIGICO 2)
Moved mass through the plunger:
28 g (DIGICO 1)
27 g (DIGICO 2)
- Supplied in transport packing with 1 lithium battery
01960007
1 lift lever 01960005
- Identification number
- Inspection report with a declaration of conformity

TESA DIGICO 1 / 2

These two indicators are remarkable for their multiple simple functions, long measuring travel and high accuracy.

- Analogue/digital display combined with the possibility of orienting the analogue display in different positions.
- Zero setting at any point within the measuring span.
- Data input via the keypad.
- Counting direction reversible.
- Entry of limit values for classification through displayed symbols. Additional green, red or amber coloured background whenever the instrument is connected to mains.
- Storage of measured values through the functions: "Maximum value", "Minimum value" or "Maximum value minus minimum value".

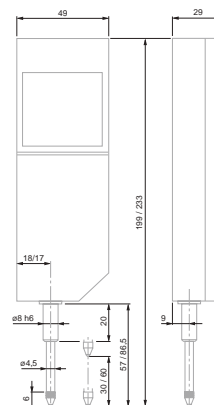

No	=				
01930000	DIGICO 1	30	1.18	0,001	0.00005
01930001	DIGICO 2	60	3.36	0,001	0.00005

OPTIONAL ACCESSORIES:

- 04761037 Mains adaptor 230V for DIGICO 1 or 2
- 04761057 Mains adaptor 110V for DIGICO 1 or 2
- 01960007 3.5 V lithium battery, LR6, AA
- 01960005 Bottom mounted lift lever
- 04768000 Hand switch for manually triggering data transfer.
Jack plug connector, 1,8 m
- TESA SPC PRINTER printer
- TESATRONIC TT display units

Force de mesure		
	DIGICO 1	DIGICO 2
Measuring force* close to measuring plunger stop		
- Bottom	0.85 N ± 0.15 N	0.90 N ± 0.20 N
- Top	1.10 N ± 0.20 N	1.45 N ± 0.25 N
Hysteresis*	0.10 N	0.15 N

* Valid with indicator in vertical position, measuring plunger oriented downwards and in static measurement.



TESA DIGICO 12

Designed to operate in a rugged environment, resistant to spray of liquids (IP65) – 44 mm dial diameter – Provides the advantages of mechanical precision with digital reading

TESA DIGICO 12 – Standard

- 44 mm dial casing diameter.
- Resistant against cutting oils and coolants (IP65).
- RS232 SIMPLEX data output combined with external power supply.
- Inductive measuring system, patented.
- Choice between absolute "ABS" and relative "REL" measuring modes.
- Digital display.
- Setting of PRESET value (± 130 mm).
- Inverse measuring direction.
- Direct conversion of metric/inch units.
- Automatic shutdown.

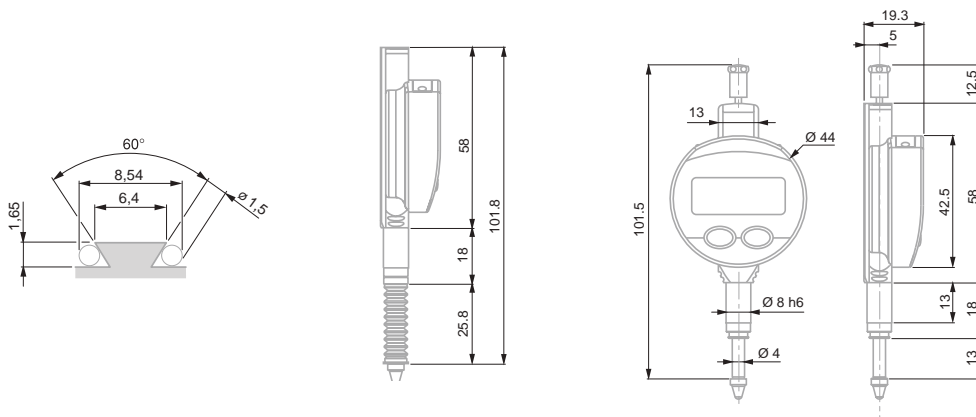

- 5-digit LC display + sign
- Digit height 6 mm
- 20 μ m
- Repeatability: 5 μ m
- 0,5 to 0,9 ($\pm 0,15$) N
- Max. 2 m/sec
- Number of measurements per second: 7
- Zero setting of display
- RS232
- 3 V lithium battery, type CR 3032
- Battery life > 3500 hours
- Working temperature range: 5°C to 40°C
- Protection level: IP65 (CEI 629)
- EN 61326-1
- 70 g
- Supplied in transport packing with 1 lithium battery, type CR 2032 (No 01961000)
- Identification number
- Declaration of conformity
- Models 0,01 mm with report, models 0,001 mm without report

	mm	in	mm	in	Protection bellows	
01930130	12,5	0.5	0,01	0.0005		IP65
01930132	12,5	0.5	0,001	0.00005		IP65
01930131	12,5	0.5	0,01	0.0005	With	IP65
01930133	12,5	0.5	0,001	0.00005	With	IP65

- +
- LCD, 5 digits + sign
- Digit height: 6 mm
- Max. permissible error: 4 µm
- Repeatability limit: 2 µm
- 0,4 to 0,75 (± 0,15) N
- Max. 2 m/sec
- Number of measurements per second: 9
- Zero-setting of display
- RS232
- 3 V lithium battery, type CR 2032
- Battery life: > 4000 hours
- Working temperature range: 5°C to 40°C
- IP65 (CEI 529)
- EN 61326-1
- 70 g
- Supplied in transport packing with 1 lithium battery, type CR 2032 (No 01961000)
- Identification number
- Inspection report with a declaration of conformity

TESA DIGICO 12 – HP

- High precision measuring system.
- Resistant to cutting oils and coolants (IP65).
- Combined analogue/digital display.
- Analogue reading from ±0.025 to ±1.25 mm.
- NOR/MIN/MAX/MAX-MIN measuring modes.
- 44 mm dial casing diameter.
- RS 232 data output combined with external power supply.
- Inductive measuring system, patented.
- Zero-setting of display.
- Direct conversion of metric/inch units.
- Shut down: either automatic or blocked.

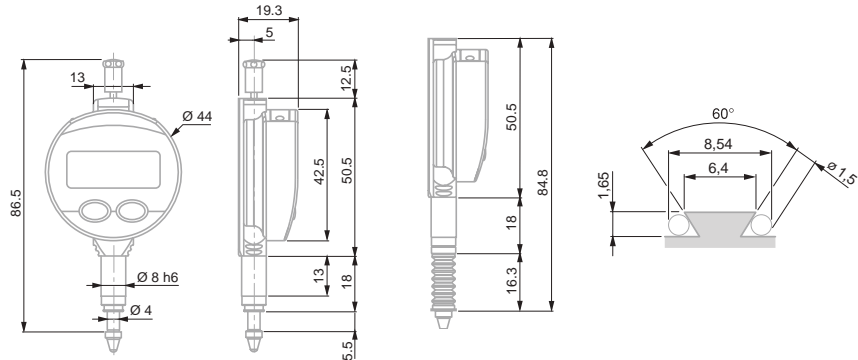

No					Protection bellows	
01930134	5	0.210	0,001	0.00005	Without	IP65
01930135	5	0.210	0,001	0.00005	With	IP65

Accessories for TESA DIGICO 12

No	=
03238013	Mounting lug
01961012	Upper lift lever
01960005	Bottom mounted lift lever
04761060	RS 232 cable with external power supply
01961000	Lithium battery, 3V, CR2032

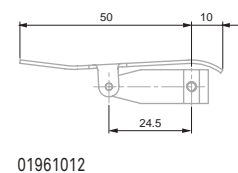
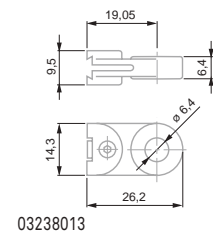

ETALON HP

High precision comparators

ETALON with short measuring travel

The ultimate in high precision.

Remarkably reliable, even when constantly used for series inspection – Specially designed for comparative measurements requiring a very low measurement uncertainty – Measures axial and radial runouts with very low hysteresis.

- Shockproof movement. Lever and gear transmission system. Long dead travel.
- Non-reflecting dial for easy readout.
- Measuring travel limited to less than one revolution of pointer. No possibility of reading errors.
- Fine adjustment with protective knob to prevent accidental displacement of the pointer.



- DIN 879-1 Dimensions according to EN ISO 463
- Full-metal dial casing. Stainless steel plunger, hardened.
- ≈1 N
- Measuring plunger on ball-bearings
- Adjustable tolerance markers. Coupling thread for retraction cable. M2,5 thread for measuring insert
- 1 measuring insert already mounted, steel ball tip Ø 3.175 mm. 1 retraction cable.
- Plastic case
- Declaration of conformity

01419051		0,1	0,001	3,0	50 ÷ 0 ÷ 50 ●	62	-
01419052		0,1	0,001	3,0	50 ÷ 0 ÷ 50 ●	62	IP54

Accuracy

	0,001 mm
	Max. perm. errors in one direction throughout the measuring range, G_e 1 μ m
	over any selected local range including 10 scale divisions, G_t 0,7 μ m
	in both measuring directions throughout the total measuring range, G_{ges} 1,2 μ m
	Repeatability limit, r_w 0,5 μ m
	Max. hysteresis, f_u 0,5 μ m

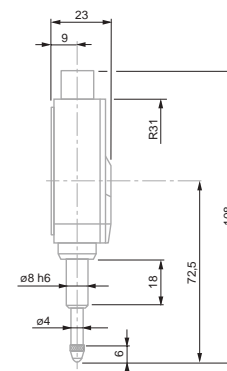

DIAL GAUGES – PREMIUM QUALITY

The TOP quality of our dial gauges guarantee the use of the best and most wear-resistant materials in order to ensure that the most demanding metrological criteria are respected along with a product life that exceeds all other dial gauges

Dial Ø 40 mm – Reading 0,01 mm

Precision dial gauges

These precision dial gauges combine excellent metrological properties with extra-long life.

- Smooth and regular travel, entirely jewel-mounted movement.
- Full-metal dial casing and bezel.
- Shockproof mechanism in both directions of plunger movement.
- Non-reflecting dial.
- Swiss-made.



01410210

353

353E

- EN ISO 463 Factory standard
- Rotating dial. With or without dial lock for standard models
- 0,01 mm
- Full-metal dial casing. Mounting shank and plunger in hardened stainless steel
- See table for tolerance limits
- With or without shockproof mechanism
- Adjustable tolerance markers. Thread M2,5 for measuring insert
- Measuring insert with 3 mm dia. ball tip already mounted
- Cardboard box
- Identification number
- Inspection report with a declaration of conformity

No	=											
		mm	mm	mm	mm							N
01410210	TESA YR	5	5,4	0,01	0,5	0 ÷ 25 ÷ 50	●	●				
01416013	MERCER X185-1	5	5,4	0,01	0,5	0 ÷ 25 ÷ 0	–	●				
01416014	MERCER 186-1	5	5,4	0,01	0,5	0 ÷ 25 ÷ 50	–	●				
01412010	TESA YE	5	5,4	0,01	0,5	0 ÷ 25 ÷ 50	–	–				
353	COMPAC 353	5	5,4	0,01	0,5	0 ÷ 25 ÷ 50	●	–				
353E	COMPAC 353E IP54	5	5,4	0,01	0,5	0 ÷ 25 ÷ 50	●	–				IP54

Permissible limits of a metrological characteristic (MPE/MPL)

		0,01 mm
	Deviation span	12 µm
	Deviation span within partial measuring span 0,10 mm	6 µm
	Total deviation span	14 µm
	Repeatability limit	3 µm
	Max. hysteresis	3 µm
	Measuring force	= 1,4 N
	– IP54 model	= 2 N

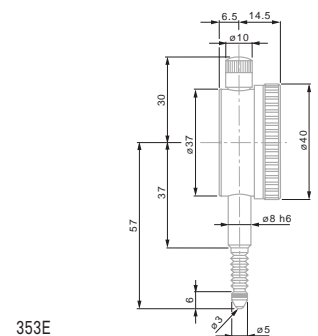
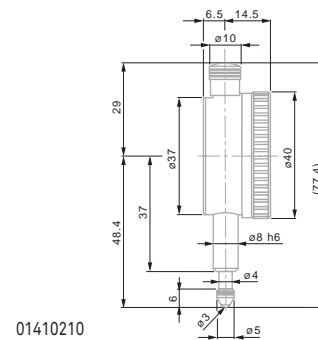

Dial Ø 57 and 58 mm – Reading 0,01 mm

Precision dial gauges



01410610



512K



532E



01416021

No	=							
		mm	mm	mm	mm			
01410610	TESA YR	10	10,5	0,01	1	0 ÷ 50 ÷ 100	●	●
01410611	TESA YR	10	10,5	0,01	1	0 ÷ 50 ÷ 0	●	●
01412310	TESA YE	10	10,5	0,01	1	0 ÷ 50 ÷ 100	-	-
01416021	MERCER 251-1	10	10,5	0,01	1	0 ÷ 50 ÷ 100	-	●
512K	COMPAC 512K	10	10,5	0,01	1	0 ÷ 50 ÷ 100	-	-
532	COMPAC 532	10	10,5	0,01	1	0 ÷ 50 ÷ 100	●	-
532E	COMPAC 532E IP54	10	10,5	0,01	1	0 ÷ 50 ÷ 100	●	- IP54
533S	COMPAC 533S limited travel	± 0.5	4	0,01	1,27	50 ÷ 0 ÷ 50	●	-

- EN ISO 463 Factory standard
- Rotating dial. With or without dial lock for standard models
- 0,01 mm
- Full-metal dial casing. Mounting shank and plunger in hardened stainless steel
- See table for tolerance limits
- With or without anti-shock mechanism
- Adjustable tolerance markers. Thread M2,5 for measuring insert
- Measuring insert with Ø 3 mm ball tip already mounted
- Cardboard box
- Identification number
- Inspection report with declaration of conformity

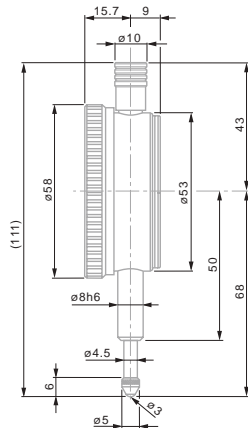

512K

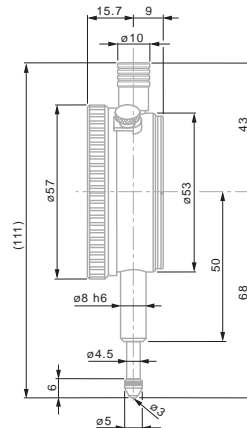

01410610 - 01410611

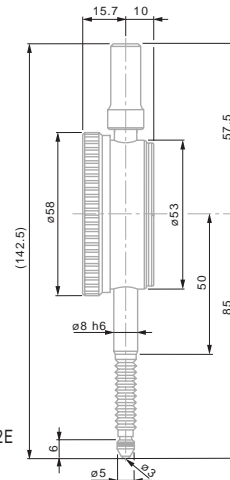

532E

Permissible limits of a metrological characteristic (MPE/MPL)

	± 0,5	10 mm
Deviation span	7 µm	15 µm
Deviation span within the selected local measuring span 0.10 mm	5 µm	8 µm
Total deviation span	9 µm	17 µm
Repeatability limit	3 µm	3 µm
Max. hysteresis	3 µm	3 µm
Measuring force – Models IP54	= 1 N -	≤ 1,5 N ≤ 2,2 N

Dial Ø 58 mm – Reading 0,01 mm – Long travel

Long range precision dial gauges



EN ISO 463
Factory standard

Rotating dial. With
or without dial lock.

0,01 mm

Full-metal dial
casing. Mounting
shank and plunger
in hardened stain-
less steel

See table for
tolerance limits

Adjustable tolerance
markers. Thread
M2,5 for measuring
insert

Measuring insert
with 3 mm ball tip
already mounted

Cardboard box

Identification
number

Inspection report
with declaration of
conformity



712

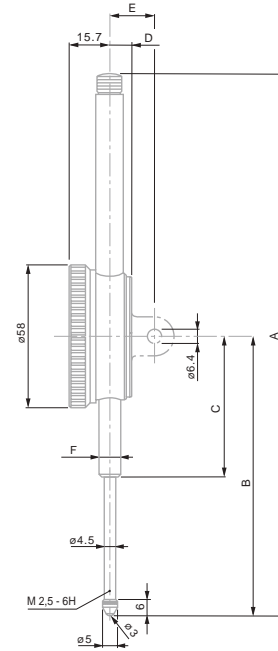

No	=	mm	mm	mm	mm	mm	mm	mm	mm
712	COMPAC 712	30	30,5	0,01	1	0 ÷ 50 ÷ 100	●	–	58
722	COMPAC 722	50	50,5	0,01	1	0 ÷ 50 ÷ 100	●	–	58
732	COMPAC 732	100	100,5	0,01	1	0 ÷ 50 ÷ 100	●	–	58

Dimensions

	30 mm	50 mm	100 mm
A	148	228	390
B	88	117,2	211,6
C	50	60	103,6
D	10	9	9
E	20	19	19
F	Ø 8h6	Ø 8h6	Ø 8h6

Permissible limits of a metrological characteristic (MPE/MPL)

	30 mm	50 mm	100 mm
Deviation span	20 µm	25 µm	30 µm
Total deviation span	25 µm	30 µm	35 µm
Repeatability limit	3 µm	3 µm	3 µm
Max. hysteresis	5 µm	5 µm	8 µm
Measuring force	≤ 2,2 N	≤ 2,5 N	≤ 3,2 N



Dial Ø 82 mm – Reading 0,01 mm

Precision dial gauges



01410910

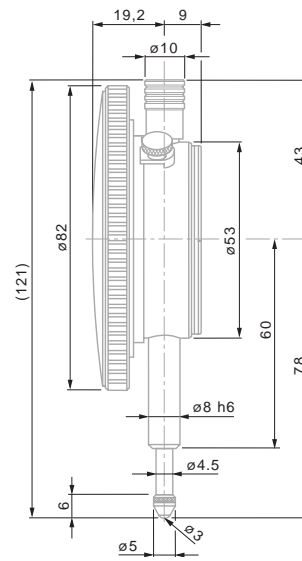

01410910



EN ISO 463
Factory Standard



Rotating dial. With
ot without dial lock



0,01 mm



Full-metal dial ca-
sing. Stainless steel
fixing shank and
plunger, hardened



See table for
tolerance limits



High performance
shock-proof system
in the 2 directions



M2,5 thread for
measuring insert



Measuring insert
with Ø 3 mm ball tip,
already mounted



Cardboard box



Identification
number



Inspection report
with declaration of
conformity

01410910	mm	mm	mm	mm	0 ÷ 50 ÷ 100	●	●
	10	10,5	0,01	0,1			

Permissible limits of a metrological characteristic (MPE/MPL)

	10 mm
	Deviation span
	15 µm
	Deviation span within partial measuring span of 0,10 mm
	8 µm
	Total deviation span
	17 µm
	Repeatability limit
	3 µm
	Max. hysteresis
	3 µm
	Measuring force
	≤ 1,4 N

Dial Ø 40 mm – Reading 0,002 mm

Precision dial gauges

- EN ISO 463 Factory standard
- Rotating dial
- 0,002 mm
- Full-metal casing. Fixing shank and plunger in hardened stainless steel
- See table for tolerance limits
- Adjustable tolerance markers. Thread M2,5 for measuring insert
- Measuring insert with Ø 3 mm ball tip already mounted
- Cardboard box
- Identification number
- Inspection report with declaration of conformity



355E



365S

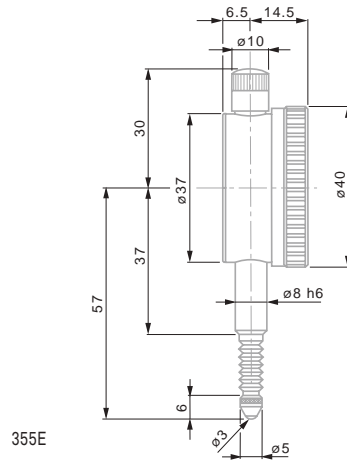

355E

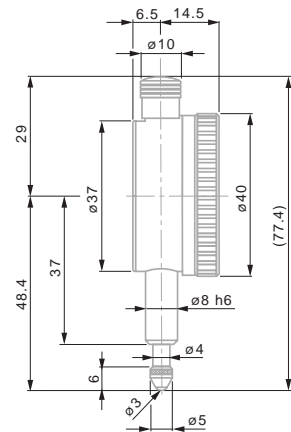

365S

	mm	mm	mm	mm						
355	3	3,3	0,002	0,2	0 ÷ 10 ÷ 20	●	-	40		
355E	3	3,3	0,002	0,2	0 ÷ 10 ÷ 20	●	-	40	IP 54	
365S	±0,08	1,5	0,002	0,2	8 ÷ 0 ÷ 8	●	-	40		

Permissible limits of a metrological characteristic (MPE/MPL)

	±0,08 mm	3 mm
Deviation span	2 µm	10 µm
Deviation span within the selected local measuring span 0,10 mm	2 µm	6 µm
Total deviation span	4 µm	12 µm
Repeatability limit	1 µm	1,5 µm
Max. hysteresis	1 µm	2 µm
Measuring force - Model IP54	≤ 1,4 N -	≤ 1,4 N ≤ 1,7 N



Dial Ø 58 mm – Reading 0,002 mm

Precision dial gauges



01416034



555



565S



555E

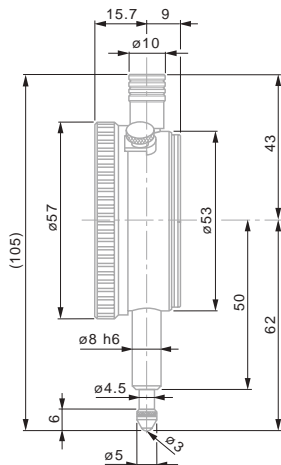

01416034

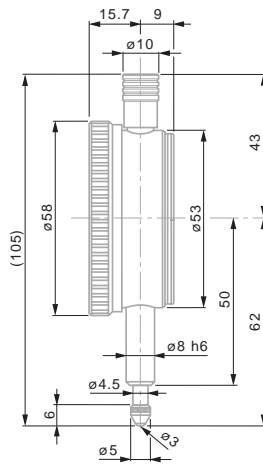

555

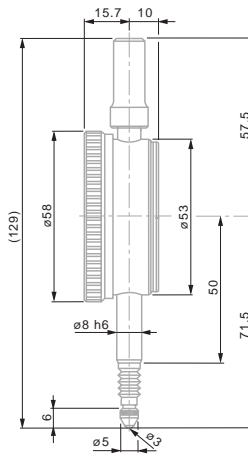

555E



EN ISO 463
Factory standard



Rotating dial. With or without dial lock.



0,002 mm



Full-metal dial casing. Mounting shank and plunger in hardened stainless steel



See table for tolerance limits



Adjustable tolerance markers. Thread M2,5 for measuring insert



Measuring insert with 3 mm ball tip already mounted



Cardboard box



Identification number



Inspection report with declaration of conformity

No	=									
		mm	mm	mm	mm					
01416034	MERCER 253-1	5	5,3	0,002	0,2	0 ÷ 10 ÷ 0	-	●	58	-
555	COMPAC 555	5	5,3	0,002	0,2	0 ÷ 10 ÷ 20	●	-	58	-
555E	COMPAC 555E IP54	5	5,3	0,002	0,2	0 ÷ 10 ÷ 20	●	-	58	IP 54
565S	COMPAC 565S limited travel	±0,08	3,3	0,002	0,2	8 ÷ 0 ÷ 8	●	-	58	-

Permissible limits of a metrological characteristic (MPE/MPL)

	±0,08 mm	5 mm
	4 µm	12 µm
	1 µm	2 µm
	1 µm	2 µm
	≤ 1,5 N	≤ 1,5 N
- Model IP54	-	≤ 1,7 N

Dial Ø 40 mm – Reading 0,001 mm

Precision dial gauges



N EN ISO 463
Factory standard

Cardboard box

0,001 mm

Full-metal dial casing. Mounting shank and plunger in hardened stainless steel

See table for tolerance limits

With shock-proof mechanism, in both directions

Adjustable tolerance markers. Thread M2,5 for measuring insert

Measuring insert with 3 mm steel ball tip already mounted

Cardboard box

No Identification number

Inspection report with declaration of conformity



01410010



01410120

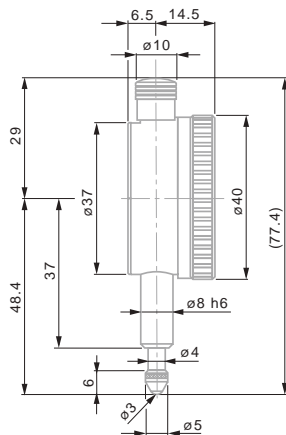

01410010

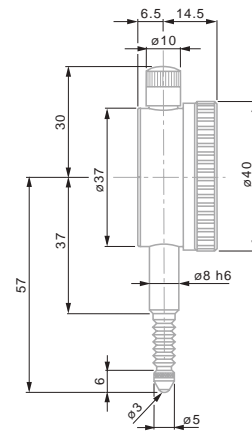

01410120

No	=										
		mm	mm	mm	mm	mm					
01410010	TESA YR	1	1,5	0,001	0,1	40	0 ÷ 50 ÷ 100	●	●	40	–
01412510	TESA YE	1	1,5	0,001	0,1	40	0 ÷ 50 ÷ 100	●	–	40	–
01410120	TESA YR IP54	1	1,5	0,001	0,1	40	0 ÷ 50 ÷ 100	●	–	40	IP 54
367	COMPAC 367	1	1,5	0,001	0,1	40	0 ÷ 5 ÷ 10	●	–	40	–
367E	COMPAC 367E IP54	1	1,5	0,001	0,1	40	0 ÷ 5 ÷ 10	●	–	40	IP 54

Permissible limits of a metrological characteristic (MPE/MPL)

	1 mm
Deviation span	4 µm
Deviation span within the selected local measuring span 0,10 mm	4 µm
Total deviation span	5 µm
Repeatability limit	1 µm
Max. hysteresis	1 µm
Measuring force – Model IP54	≤ 1,7 N ≤ 2 N



Dial Ø 58 mm – Reading 0,001 mm

Precision dial gauges



01412511



556



01412611

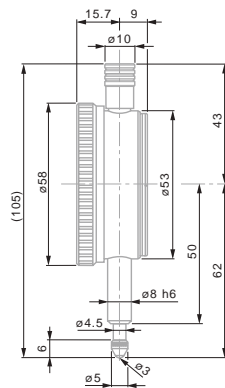

567

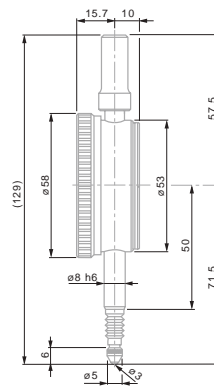

556E



EN ISO 463
Factory standard



0,001 mm



Full-metal dial casing. Mounting shank and plunger in hardened stainless steel



See table for tolerance limits



Effective anti-shock in the 2 directions



Adjustable tolerance markers. Thread M2,5 for measuring insert



Measuring insert with 3 mm Ø ball tip, already mounted



Cardboard box



Identification number



Inspection report with declaration of conformity

No	Symbol	mm	mm	mm	mm	mm	mm	mm	mm	mm	mm	mm
01412511	TESA YE	1	1,5	0,001	0,1	58	0 ÷ 50 ÷ 100	●	-			
01412611	TESA YE	5	5,3	0,001	0,2	58	0 ÷ 100 ÷ 200	●	-			
556	COMPAC 556	5	5,3	0,001	0,2	58	0 ÷ 10 ÷ 20	●	-			
567	COMPAC 567	1	3,3	0,001	0,1	58	0 ÷ 5 ÷ 10	●	-			
556E	COMPAC 556E IP54	5	5,3	0,001	0,2	58	0 ÷ 10 ÷ 20	●	-			IP54
01412711	TESA YE IP54	1	1,5	0,001	0,1	58	0 ÷ 50 ÷ 100	●	-			IP54
01410520	TESA YR IP54	1	3,3	0,001	0,1	58	0 ÷ 50 ÷ 100	●	-			IP54

Permissible limits of a metrological characteristic (MPE/MPL)

	1 mm	5 mm
Deviation span	4 µm	12 µm
Deviation span within the selected local measuring span 0,10 mm	4 µm	-
Total deviation span	5 µm	14 µm
Repeatability limit	1 µm	2 µm
Max. hysteresis	1 µm	2 µm
Measuring force	≤ 1,7 N	≤ 1,5 N
- Models IP54	-	≤ 1,7 N

Dial Ø 82 mm – Reading 0,001 mm

Precision dial gauges



N EN ISO 463
Factory standard

Rotating dial. With or without dial lock.

0,001 mm

Full-metal dial casing. Stainless steel fixing shank and plunger, hardened

See table for tolerance limites

High performance anti-shock system in both directions

M2,5 thread for measuring inserts

Measuring insert with Ø 3 mm ball tip, already mounted

Cardboard box

No Identification number

Inspection report with a declaration of conformity

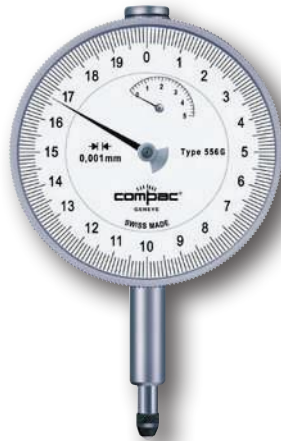

556G



01410810

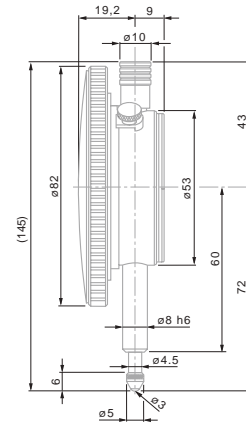

01410810

			mm	mm	mm	mm				
01410810	TESA YR	1	3,3	0,001	0,1	0 ÷ 50 ÷ 100	●	●		82
556G	COMPAC 556G	5	5,3	0,001	0,2	0 ÷ 10 ÷ 20	●	-		82

Permissible limits in a metrological characteristic (MPE/MPL)

	1 mm	5 mm
Deviation span	4 µm	12 µm
Deviation span within partial measuring span of 0,10 mm	4 µm	-
Total deviation span	5 µm	14 µm
Repeatability limit	1 µm	2 µm
Max. hysteresis	1 µm	2 µm
Measuring force	≤ 1,7 N	≤ 1,5 N



STANDARD DIAL GAUGES

The Standard product line offers a range of heavy duty and competitively priced dial gauges.

Dial Ø 40 / 58 – Reading 0,1 mm

Precision dial gauges

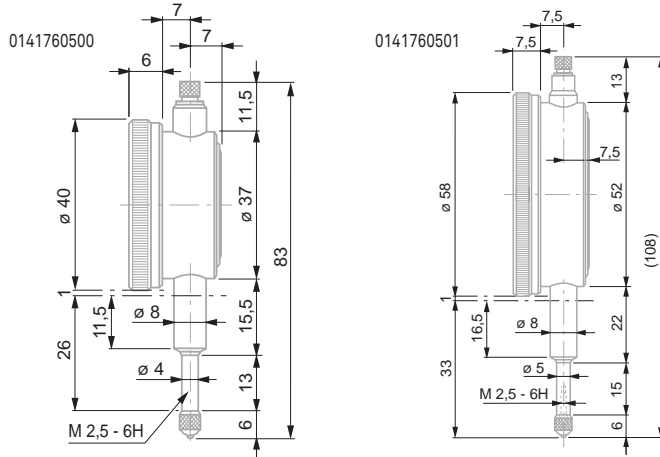

0141760500
0141760501

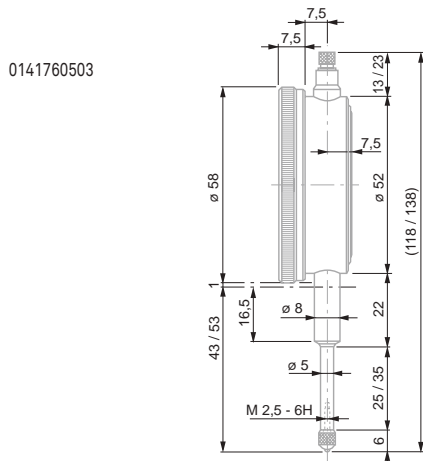

0141760503



- EN ISO 463
Factory standard
- Rotating dial
- 0,1 mm
- Full-metal casing.
Mounting shank and
plunger in hardened
stainless steel
- See table for
tolerance limits
- Without anti-shock
mechanism
- Thread M2,5 for
measuring insert
- Measuring insert
with 3,175 mm
Ø ball tip already
mounted
- Plastic case
- Identification
number
- Declaration of
conformity

0141760500	10	10,5	0,1	10	0 ÷ 5 ÷ 10	-	≤ 1,0
0141760501	10	10,5	0,1	10	0 ÷ 5 ÷ 10	-	≤ 1,0
0141760503	30	30,5	0,1	10	0 ÷ 5 ÷ 10	-	≤ 1,5

Permissible limits of a metrological characteristic (MPE/MPL)

	10 mm
Deviation span	40 µm
Deviation span within partial measuring span of 0.1 mm	25 µm
Total deviation error	55 µm
Repeatability limit	15 µm
Max. hysteresis	15 µm

- EN ISO 463
Factory standard
- Rotating dial
- 0,01 mm
- Full-metal casing.
Mounting shank and
plunger in hardened
stainless steel
- See table for
maximum deviations
- With or without anti-
shock mechanism
- Adjustable tolerance
markers. Thread
M2,5 for measuring
insert
- Measuring insert
with 3,175 mm
Ø ball tip already
mounted
- Plastic case or
cardboard box
- Identification
number
- Inspection report
with declaration of
conformity

Dial Ø 40 mm – Reading 0,01 mm

Precision dial gauges

Model 0141760560 provides excellent value for money.



0141760560



01419047

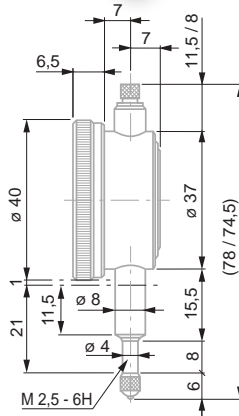

0141760560

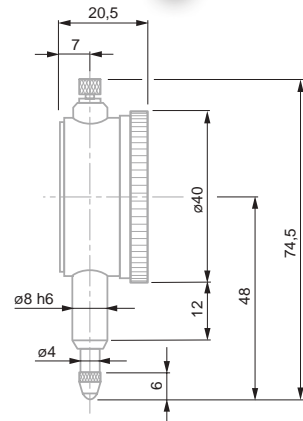

01419047

				mm	mm	mm	mm		
0141760560 *			ROCH	3	3,4	0,01	0,5	0 ÷ 25 ÷ 50	-
01419047			ETALON	5	-	0,01	0,5	0 ÷ 25 ÷ 50	●

* With extra reverse numbering in red

Permissible limits of a metrological characteristic (MPE/MPL)

	3 mm	5 mm
Deviation span	10 µm	12 µm
Deviation span within the selected partial measuring span of 0,1 mm	5 µm	6 µm
Total deviation span	12 µm	-
Repeatability limit	3 µm	3 µm
Max.hysteresis	3 µm	-
Measuring force	≤ 1,4 N	≈ 1



Dial Ø 58 mm – Reading 0,01 mm – Long travel

Long travel precision dial gauges



0141760635



0141760624



0141761213



0141760661



0141760651

0141760631
0141760635

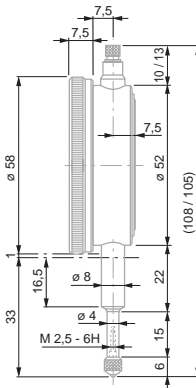

0141761213

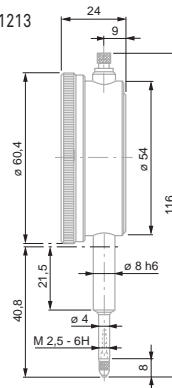

0141760624

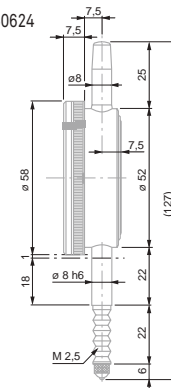

0141760651
0141760653

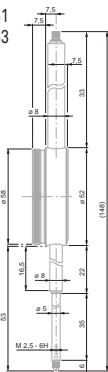

0141760661

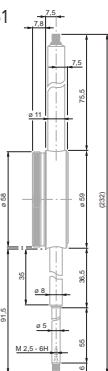

No	≡								
0141760631 *	ROCH	10	10,5	0,01	1	0 ÷ 50 ÷ 100	-	≤ 1,4	
0141760635 *	ROCH	10	10,5	0,01	1	0 ÷ 50 ÷ 100	-	≤ 1,4	
0141761213 **	ROCH	15	15,5	0,01	1	0 ÷ 50 ÷ 100	●	≤ 1,6	
0141760651	ROCH	30	30,5	0,01	1	0 ÷ 50 ÷ 100	-	≤ 1,6	
0141760653	ROCH	30	30,5	0,01	1	0 ÷ 50 ÷ 100	●	≤ 2,2	
0141760624 *	ROCH IP54	10	10,5	0,01	1	0 ÷ 50 ÷ 100	●	≤ 2	IP54
0141760661	ROCH	50	51	0,01	1	0 ÷ 50 ÷ 100	-	≤ 2,2	

* With extra reverse numbering in red

** Ø Dial 60,4 mm

Permissible limits of a metrological characteristic (MPC/MPE)

	10 mm	15 mm	30 mm	50 mm	80 mm
	15 µm	20 µm	20 µm	25 µm	30 µm
	5 µm	5 µm	5 µm	5 µm	5 µm
	3 µm	3 µm	3 µm	3 µm	3 µm



EN ISO 463
Factory standard



Rotating dial



0,01 mm



Full-metal casing.
Mounting shank and
plunger in hardened
stainless steel



See reference table



With or without anti-
shock mechanism



Adjustable tolerance
markers. Model No.
0141760640 with fine
adjust for dial reading
mounted under
protective cap. Thread
M2,5 for measuring
insert



Accuracy: see table
for max. deviations.
If measurements are
carried out with a
downward plunger,
the same must be
mechanically
coupled to the
measuring point
to eliminate all
hysteresis



Measuring insert
with Ø 3,175 mm
steel ball tip,
already mounted.
Exceptions:
Model numbers
0141760631 /
0141761213 with
ruby ball tips.



Plastic case or
cardboard box



Identification
number



Declaration of
conformity

Dial Ø 58 mm – Reading 0,01 mm – Standard and long travel

Precision dial gauges

Standard and long travel models

- EN ISO 463 Factory standard
- Rotating dial
- 0,01 mm
- Full-metal casing. Mounting shank and plunger in hardened stainless steel
- See reference table
- With or without anti-shock mechanism
- Adjustable tolerance markers. Thread M2,5 for measuring insert
- Measuring insert with Ø 3,175 mm steel ball tip, already mounted
- Plastic case or cardboard box
- Identification number
- Declaration of conformity



01419048

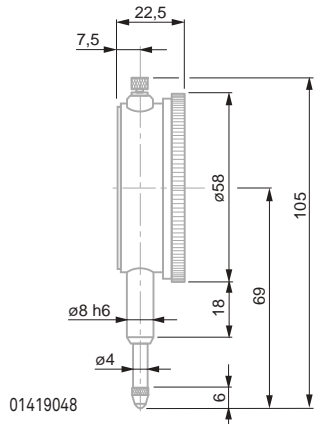

01419048

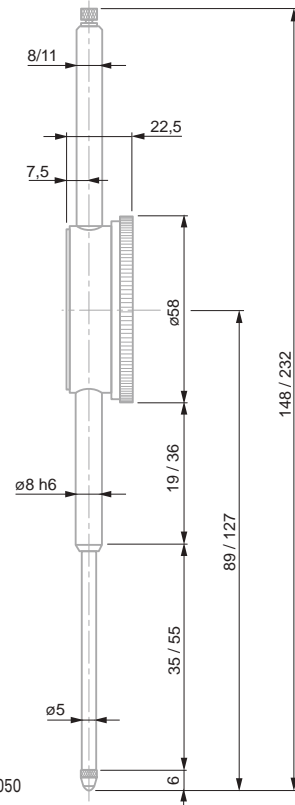

01419050

	mm	mm	mm			N	
01419048	10	0,01	1	0 ÷ 50 ÷ 100	–	≈1	58
01419050	50	0,01	1	0 ÷ 50 ÷ 100	●	1,5 ÷ 2	58

For magnetic or central lug backs, see backs for ROCH and ETALON dial gauges

Permissible limits for a metrological characteristic (MPE/MPL)

	mm	10	50
	Deviation span	µm	15 25
	Deviation span within selected partial measuring span 0,10 mm	µm	8 12
	Repeatability Limit	µm	3 3



DIAL GAUGES – ANALOGUE WITH BACK MOUNTED PLUNGER

Mechanical dial gauges with back mounted plungers differentiate by their concept of presenting a display which is perpendicular to the movement of the measuring stem.

Dial Ø 40 mm – Reading 0,01 or 0,002 mm



CP352S



CP353



CP355

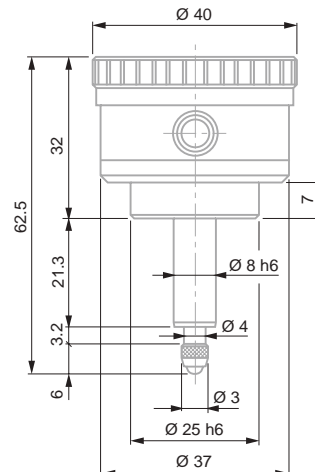

CP353



EN ISO 463
Factory standard



Rotating dial



Full-metal casing.
Mounting shank and
plunger in hardened
stainless steel



See reference table



With anti-shock
mechanism



Adjustable tolerance
markers. Thread
M2,5 for measuring
insert. Fastening
with sleeve Ø 8h6
and 25h6



Measuring insert
with Ø 3 mm steel
ball tip, already
mounted



Cardboard box



Identification
diameter



Inspection report
with declaration of
conformity

		mm	mm	mm	µm	µm	µm	mm	mm	N		
CP 353	COMPAC CP353	3	3,2	0,01	14	3	3	0,5	0 ÷ 25 ÷ 50	0,9		
CP 355	COMPAC CP355	3	3,2	0,002	14	2,2	2,5	0,2	0 ÷ 10 ÷ 20	0,9		
CP 352S	COMPAC CP352S with limited travel	± 0,4	3,2	0,01	9	3	3	(1)	40 ÷ 0 ÷ 40	0,9		

S: Limited range of indication, restricted reading.
The needle makes less than one revolution of the dial, all reading errors due to revolution counter are eliminated.

INSERTS FOR DIAL GAUGES, AXIAL PROBES, ETC. - EXECUTION WITH M2,5 THREAD

Spherical measuring inserts, standard.

No	
03510001	Steel
03510002	Carbide
03560001	Sapphire

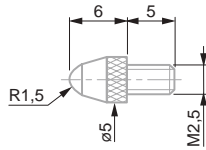

Spherical measuring insert, short

No	
03560007	Carbide

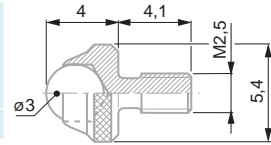

Spherical measuring inserts, long

No	
03560019	Steel
03560020	Carbide
03560021	Ruby

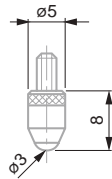

Spherical measuring inserts, R = 0,5 mm.

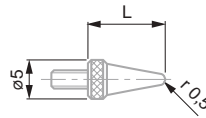

No			L mm
03560035	Steel		5
03560036	Steel		10
03560037	Steel		15
03560038	Steel		20
03560039	Steel		30
03560040	Steel		40

Spherical measuring inserts

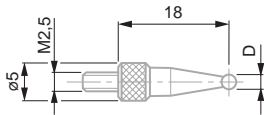

No			D, mm
03560051	Carbide		1
03560052	Carbide		2
03560053	Carbide		3
03560054	Carbide		4
03560055	Carbide		5
03560056	Carbide		6
03560057	Carbide		7
03560058	Carbide		8

Spherical measuring insert with 4 interchangeable pins, R = 1,5 mm

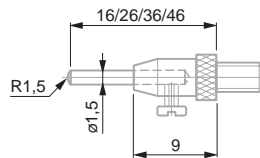

No			L, mm
03510201	Steel		16, 26, 36, 46

Spherical measuring inserts

No	
03510101	Steel
03510102	Carbide

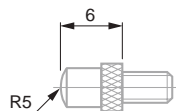

Spherical measuring inserts

No	
03560017	Steel
03560018	Carbide

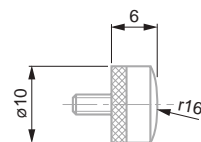

Measuring insert with offset (A)
Pointed measuring face
Lock nut for radial alignment.

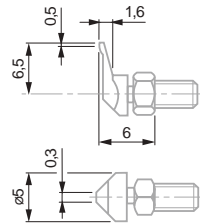

Measuring insert with offset (A)
Pointed measuring face
Lock nut for radial alignment.

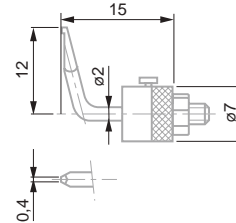

Measuring insert with needle contact point

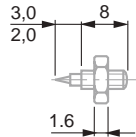

Measuring inserts with ball-bearing rollers
Lock nut for radial alignment

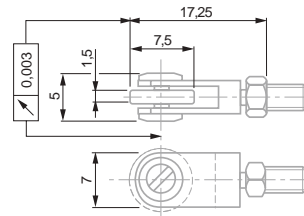

No			
		Shape	
03560010		Cylindrical	Steel
03560011		Domed	Steel

Inserts with a knife blade measuring face
Lock nut for radial alignment

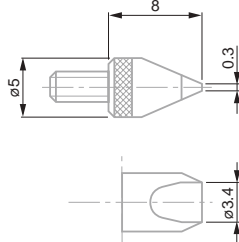

No			B, mm
03560024	Steel		0,3
03560025	Steel		0,3

Inserts with a knife blade steel face
Lock nut for radial alignment

No			L, mm
03560031			5
03560032			10
03560033			15
03560034			20

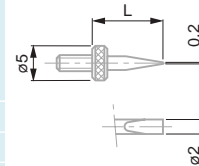

Insert with a cylindrical measuring face
Lock nut for radial alignment

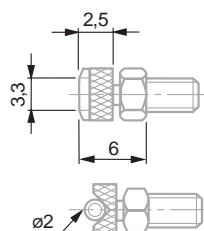
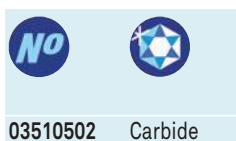

Insert with a narrow, off-centre measuring face
Lock nut for radial alignment

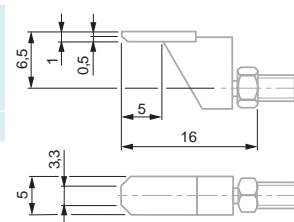

Insert with a narrow measuring face
Parallelism adjustable
Lock nut for radial alignment



03510702 Carbide

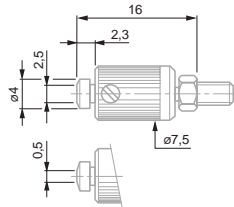

Inserts with a flat measuring face.

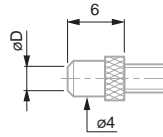

03510801	2,5	Steel
03510802	2,5	Carbide
03560022	3,4	Steel
03560023	3,4	Carbide

Insert with a flat measuring face
Parallelism adjustable
Counter-nut for radial alignment



03510902 Métal dur

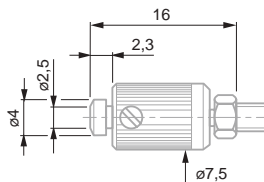

Inserts with a flat measuring face, in steel

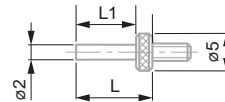

No.	L, mm	L1, mm
03560026	5	2,8
03560027	10	7,8
03560028	15	12,8
03560029	20	17,8

Inserts with interchangeable pins
Flat measuring face



03560008 Steel
03560009 Carbide

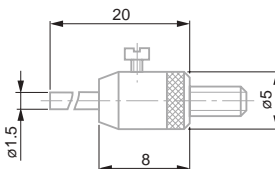

Inserts with flat measuring face

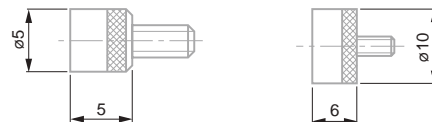

03560012	5	Steel
03560013	5	Carbide
03560014	10	Steel
03560015	10	Carbide
03560016	20	Steel

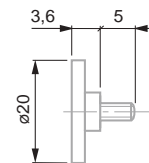

Connectors for measuring inserts

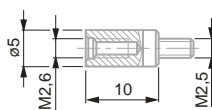

No.	Outside	Inside
03560092	M2,5	M2
03560065	M3	M2,5

Extensions for measuring inserts



No.	L, mm
03560042	10
03560043	15
03560044	20
03560045	25
03560046	30
03560047	35
03560048	40
03560049	45
03560050	50

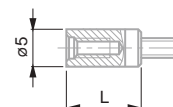

Extensions for measuring inserts.

No	L, mm
03540501	10
03540502	15
03540503	20
03540504	40

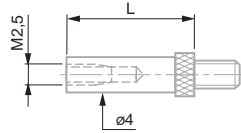

– EXECUTIONS WITH A M2 COUPLING THREAD



Spherical measuring inserts, M2 thread

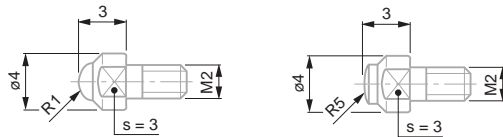

No	mm	
03510204	R 1	Carbide
03510103	R 5	Carbide

Spherical measuring inserts, R = 5 mm, M2 thread

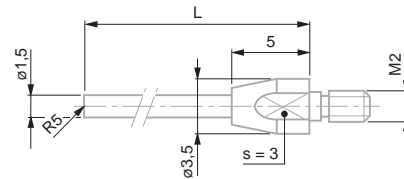

No		L, mm
03510202	Carbide	16
03510203	Carbide	26

Measuring insert with cylindrical measuring face. Lock nut for radial alignment, M2 thread

No	Carbide
03510503	

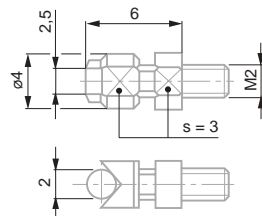

Extensions for measuring inserts, M2

No	L, mm
03540505	10
03540506	15

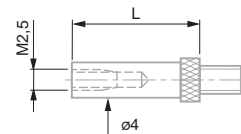

ADDITIONAL ACCESSORIES FOR DIAL GAUGES



Device for plunger retraction for mounting on the bottom stem



No



Consisting of:

- 03540104 - 03540101: Lever
- 03540102: Washer

Device for plunger retraction for mounting on the top stem

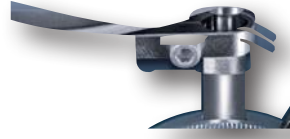

No



mm

- 03560004 Ø 40
03560005 Ø 58



Retraction lever Bottom mounted lift lever

No



- 01960005 Bottom mounted lift lever
Contains only lifting lever



90° angle probe. For the transmission of movements of the measuring plunger. Max. travel up to 10 mm. For dial gauges of 0,01 mm

No



- 03560006 90° angular probe
03560012; Insert with flat measuring face, Ø 5 mm



Magnetic force = 150 N

A Matt chrome plated except for tinted model numbers 01460010, 01460011

Backs for ROCH and ETALON Dial Gauges

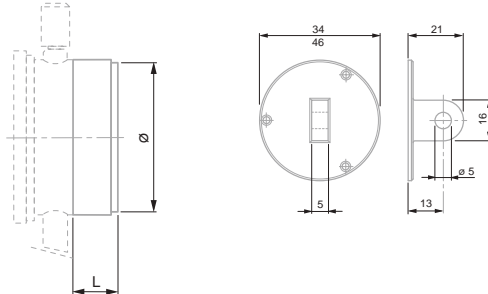

No



Bezel diameter, mm



Back, mm



- 01462004 40 34 Back with central lug
01462005 58, 60, 80 46 Back with central lug

Backs for dial gauges TESA YR – YE / MERCER / COMPAC / DIGICO 200-700 – Ø 40 mm dial models

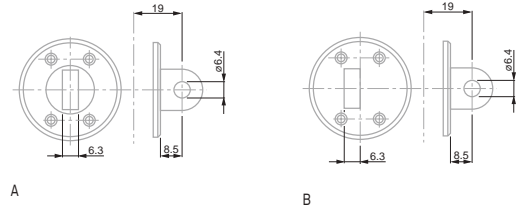

No



- 01460008 A – back with centre lug
01460009 B – Back with offset lug



Magnetic holding force = 150 N

A Dull chrome-plated except for model numbers 01460016, 01460017.

Backs for dial gauges TESA YR – YE / MERCER / COMPAC / DIGICO 200-700 – Ø 58 and 82mm dial models



- 01460014 C
01460015 D

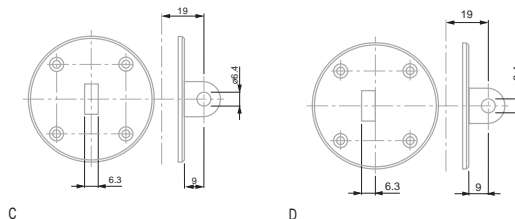



Lever-type Dial Test Indicators



TESA IP65 Electronic Dial Test Indicators

Provides the advantages of a mechanical test indicator with a digital reading.



- Inductive patented measuring system.
- Analogue and digital indication.
- Digital step of 0,01/0,001 mm.
- Selectable scale division: 10, 20, 50 μm /1, 2, 5 μm .
- Cutting oils and liquid coolant resistant (IP65).
- Metric/inch conversion.
- RS232 data output combined with external power supply.
- Displayed measuring modes (NOR/MIN/MAX/MAX-MIN).
- Automatic shut-down.
- Compatible with all TESAST accessories.

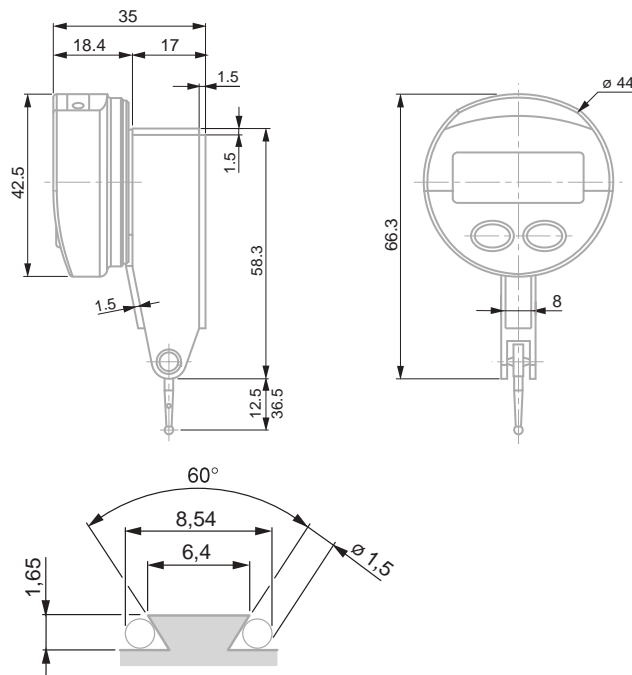

- LCD, 5 digits + unit
- Resolution to 0,01/0,001 mm; 0.0005/0.00005 in
- Display digit height 6 mm
- Max. perm. errors: $f_e = 10 \mu\text{m}$; $f_{ges} = 13 \mu\text{m}$; Pre-span = 0,05 mm
- Repeatability: $f_w = 1 \mu\text{m}$
- Hysteresis: $f_h = 3 \mu\text{m}$
- L = 12,5 mm; max. 0,05 m/s; L = 36,5 mm; max. 0,15 m/s
- Number of measurements per second: 9
- Zero-setting
- RS232
- 3 V lithium battery, type CR2032
- Battery life > 4000 hours
- Operating temperature range: +5°C to +40°C
- Degree of protection: IP65 (IEC 529)
- EN 61326-1
- 73 g (L = 12,5 mm); 75 g (L = 36,5 mm)
- Supplied in a plastic case with:
1 Insert with a 2 mm dia. (No. 01860202)
1 Wrench (No. 01860307)
1 Mounting rod 8 mm dia. (No. 01840105)
- Identification number
- Declaration of conformity

01830001	0,8	0,01/0,001	0.0005/0.00005	0,13	12,5
01830002	0,5	0,01/0,001	0.0005/0.00005	0,07	36,5

OPTIONAL ACCESSORIES:

- 01961000 Lithium battery, 3V, CR2032
 - 04761060 RS 232 cable with external power supply
- Compatible with all TESAST measuring inserts and accessories





DIN 2270
NFE 11-053

TESATAST DIAL TEST INDICATORS

These lever-type dial test indicators are especially intended for use on the shop floor or in the inspection room – Ideally suited for comparative measurements on a surface plate, for instance – Determine form, shape and position deviations as well as axial and runout errors.

- Bidirectional measuring with automatic reversal inside the movement.
- Continuous clockwise pointer rotation providing error-free reading.
- Insensitive to magnetic fields.
- Jewelled movement with 7 rubies.
- Ball-bearing lever system. Measuring insert swivelling through to 240°.
- Very low measuring force.
- Exceptionally robust with full-metal construction.

Standard model

Well proven over thousands of times. The dial face is parallel to the axis of the measuring insert.

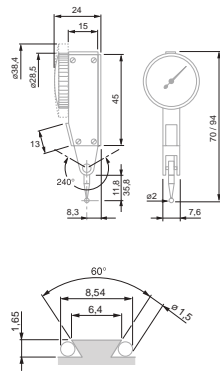

Perpendicular model

Lever test indicator with dial face mounted at right angle to the axis of the measuring insert.

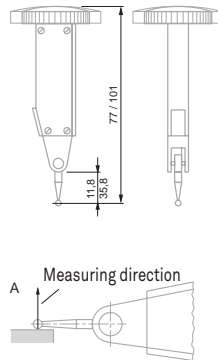

Lateral Model

Dial test indicator with dial face mounted parallel to the axis of the measuring insert but on the flat side of the dial housing.

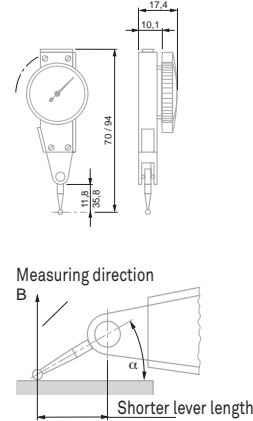

Note on the use of TESATAST dial test indicators

With the measuring insert lying parallel to the workpiece surface (Fig. A), these indicators give true reading due to the amplification factor to 1:1.

In another measuring position (angle α in Fig. B), the effective lever length changes so that the read value needs to be corrected. With respect to this, also refer to the instruction manual.

Permissible limits of a metrological characteristic (MPE/MPL)

		0,02 mm	0,01 mm	0,002 mm
Deviation span, f_e		27 μm	10 μm	2 μm
Deviation span within the local measuring span, f_t	0,20 mm	12 μm		
	0,10 mm		5 μm	
	0,02 mm			1 μm
Total deviation span, f_{ges}		31 μm	13 μm	3,5 μm
Repeatability limit, f_w		4 μm	3 μm	1 μm
Max. hysteresis, f_u		4 μm	3 μm	1,5 μm
Measuring force with insert:	Length	12,53 mm	0,15 N	0,15 N
		36,53 mm	0,06 N	0,06 N





TESATAST Standard Models

No					
	mm	mm	Ø, mm		Insert, mm
01810005	0,8	0,01	28	0 ÷ 0,4 ÷ 0	12,53
01810006	0,8	0,01	38	0 ÷ 0,4 ÷ 0	12,53
01810007	0,5	0,01	28	0 ÷ 0,25 ÷ 0	36,53
01810008	0,5	0,01	38	0 ÷ 0,25 ÷ 0	36,53
01810009	0,2	0,002	28	0 ÷ 100 ÷ 0	12,53
01810010	0,2	0,002	38	0 ÷ 100 ÷ 0	12,53
S18001695	0,2	0,001	38	0 ÷ 100 ÷ 0	12,53



SWISSTAST Standard Models

No					
	mm	mm	Ø, mm		Insert, mm
01811000	0,8	0,01	28	0 ÷ 0,4 ÷ 0	12,53
01811001	0,2	0,002	38	0 ÷ 100 ÷ 0	12,53

Same technical data as standard models, but equipped with a 2 mm dia. ruby ball tip No. 01860302.



TESATAST Perpendicular Models

No					
	mm	mm	Ø, mm		Insert, mm
01810204	0,8	0,01	28	0 ÷ 0,4 ÷ 0	12,53
01810205	0,5	0,01	28	0 ÷ 0,25 ÷ 0	36,53
01810304	0,2	0,002	38	0 ÷ 100 ÷ 0	12,53

- DIN 2270
NF E 11-053
- Rotating dial
- Very low measuring force, see table.
- Movement with patented shock proof system
- Lever system with friction drive to prevent overload
- Accuracy: see table.
- Supplied in a plastic case together with:
1 Insert with a 2 mm dia.
1 Wrench (No. 01860307)
1 Mounting rod 8 mm dia. (No. 01840105)
- Identification number
- Declaration of conformity

TESATAST Lateral Models



No					
	mm	mm	∅, mm		Insert, mm
01810011	0,8	0,01	28	0 ÷ 0.4 ÷ 0	12,53
01810012	2	0,02	38	0 ÷ 1.0 ÷ 0	36,53
01810013	0,2	0,002	28	0 ÷ 100 ÷ 0	12,53



M1,4 coupling thread

Ball tip made of carbide or ruby

TESATAST Measuring Inserts

No			
	Ball tip, mm	Ball tip material	mm
01860201	1	Carbide	12,53
01860202	2	Carbide	12,53
01860203	3	Carbide	12,53
01860211	1	Carbide	36,53
01860212	2	Carbide	36,53
01860213	3	Carbide	36,53
01860301	1	Ruby	12,53
01860302	2	Ruby	12,53
01860303	3	Ruby	12,53
01860304	1	Ruby	36,53
01860305	2	Ruby	36,53
01860307	Wrench for inserts		

Note:

The original measuring insert mounted on every TESATAST as well as any other insert of the same nominal length but with a different ball tip diameter are fully interchangeable.

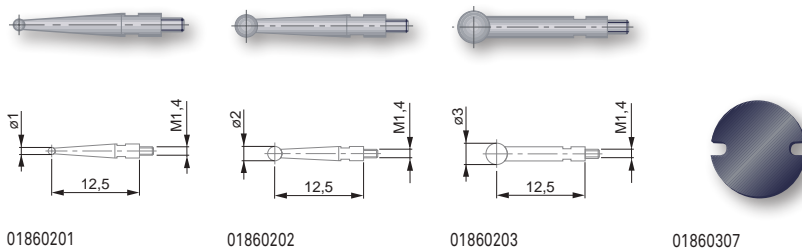

DIN 2270
NFE 11-053

Technical data: see description for each product

Plastic case

Identification number

Declaration of conformity

Indicator Sets with Small Support

No	
01630003	Indicator set with small support
COMPOSITION OF THE SETS:	
01810005	TESATAST standard model
01810010	TESATAST standard model
01860203	Carbide measuring insert
01840104	Mounting rod
01840105	Mounting rod
01860307	Wrench for inserts
01639007	Magnetic support INTERAPID UJ15, dovetail clamp and ∅ 8 mm cylindrical clamping





Accessories for TESATAST

Clamp

No	=		mm
01860401			Ø 5,6 / Ø 9,5



01860401

Mounting Rods

No	=		mm
01840404			Ø 8 x 25
01840405			Ø 8 x 90
01840406			Ø 8 x 25 (Ø 8 for clamping bore)
01840501			Ø 8 x 25 (Ø 4 for clamping point)
01840407			Ø 8 x 125



01840501



01840404



01840405



01840406



01840407

Fixing Shank

No	=		mm
01840104			Ø 4
01840105			Ø 8
01840202			Ø 8 x 80 (Ø 5,6 for the tenon)
01860008			Ø 6

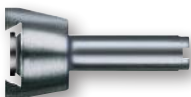

01840104



01840105



01840202

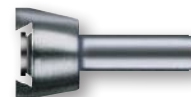

01860008



INTERAPID 312 LEVER DIAL TEST INDICATORS

INTERAPID 312 Dial Test Indicators very large measuring span – Ideal for inspecting all significant size variations, e.g. on the surface plate – Measures position, form and shape errors.



- Safe reading thanks to secondary pointer totalling the number of revolutions made by the main pointer.
- Bidirectional measuring with automatic reversal within the movement.
- Pointer rotation direction is always constant due to automatic reversal effect.
- Jewelled movement with rubies.
- Ball-bearing lever system. Measuring insert swivelling through 210°.
- Particularly robust due to full-metal construction.
- Monobloc housing with mounting through dovetail clamping and a Ø 4 mm swivelling shank.

Stylus insert with angular position of 12°

All models INTERAPID 312 are designed to give a true reading when the angle between the stylus and the workpiece surface is 12° (Fig. A). In any other measuring position, including parallel position of the stylus against the workpiece surface, measured readings have to be corrected accordingly (Fig. B). Please consult the instruction manual on this subject.

Standard Model

Time-tested dial test indicator. The dial face is mounted parallel to the axis of the insert.

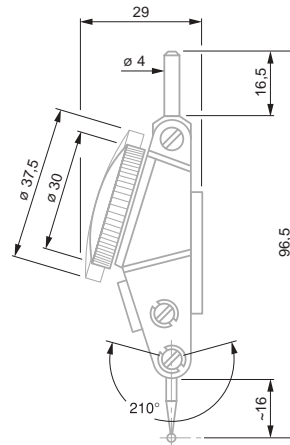

Perpendicular model

Dial test indicator with dial face mounted at right angle to the axis of the insert.

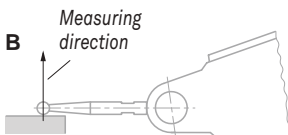
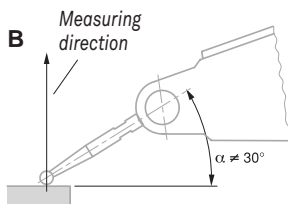
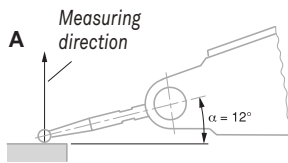
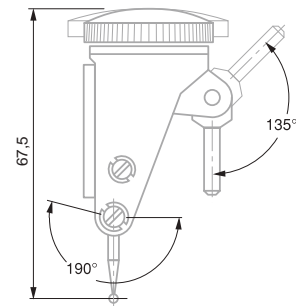

Permissible limits of a metrological characteristic (MPE/MPL)

	0,01 mm		0,002 mm	
	Pointer revolution		Pointer revolution	
Deviation range over partial measuring range, f_e	1	2	1	2
Total deviation range, f_{ges}	10 μ m	20 μ m	4 μ m	8 μ m
Repeatability limit, f_w	3 μ m		1 μ m	
Max. hysteresis, f_u	3 μ m		2 μ m	
Measuring force	0,12 N		0,25 N	





INTERRAPID 312 Standard Models

No	mm	mm	∅, mm		Insert, mm
074111366	1,6	0,01	37,5	0 ÷ 40 ÷ 0	16,5
074111367	1,6	0,01	30	0 ÷ 40 ÷ 0	16,5
074111368	0,4	0,002	37,5	0 ÷ 10 ÷ 0	15,2
074111369	0,4	0,002	30	0 ÷ 10 ÷ 0	15,2

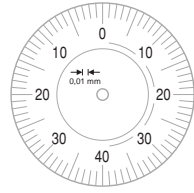

074111366



074111367

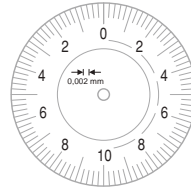

074111368

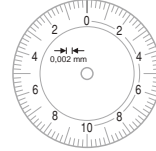

074111369



INTERRAPID 312 Perpendicular Models

No	mm	mm	∅, mm		Insert, mm
074111375	1,6	0,01	37,5	0 ÷ 40 ÷ 0	16,5
074111376	1,6	0,01	30	0 ÷ 40 ÷ 0	16,5

Dial Test Indicator Sets, Complete with Accessories – INTERRAPID 312 Standard Models

Each full set consists of:



No	
	INTERRAPID 312 lever test indicators as listed in the table below:
074106331	Rectangular mounting attachment
074108942	Reducing sleeve, metric
074106026	Swivel holder, metric
074111474	Case for measuring inserts
01860307	Wrench for measuring inserts

No	074111366	074111367	074111368	074111369	074106331	074108942	074106026	074111474	01860307
074111502	•			•	•	•	•	•	•
074111503		•		•	•	•	•	•	•
074111504			•	•	•	•	•	•	•
074111505				•	•	•	•	•	•



Rotating dial

Very low measuring force: (see table for tolerance limits)

Lever system with friction drive to prevent overload

Accuracy: see table for tolerance limits

Supplied in a plastic case with:
1 with a ∅ 2 mm insert in hardened steel,
1 stylus key
No. 01860307

Declaration of conformity



Technical data: see description for each product

Plastic case

Declaration of conformity



M1,7 coupling thread

Ball tips in hardened steel or tungsten carbide

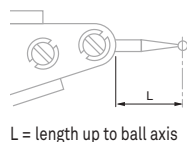

Measuring Inserts

No	mm	Ball tip, mm	Ball tip material	L mm
074107893	0,01	2	Steel	16,5
074107895	0,01	1,5	Steel	16,5
074107897	0,01	0,8	Steel	16,5
074110481	0,002	2	Steel	15,2
074110492	0,002	1,5	Steel	15,2
074110493	0,002	0,8	Steel	15,2
074105993	0,01	2	Carbide	16,5
074105994	0,01	1,5	Carbide	16,5
074105995	0,01	0,8	Carbide	16,5
074106358	*	2	Carbide	36,6
074106360	*	0,8	Carbide	36,6
074110482	0,002	2	Carbide	15,2
074110491	0,002	1,5	Carbide	15,2
074110507	0,002	0,8	Carbide	15,2

* The length of the insert used changes the amplification factor of the lever system. The values read off must therefore be doubled.



Accessories for INTERAPID 312

Clamping Attachment

No	=	mm
074108603	Double attachment with clamping point and dovetail	∅ 4

Holders

No	=	mm
074106026	Swivel holder with clamping points and dovetail	∅ 8 x 133 (∅ 4 for clamping point)

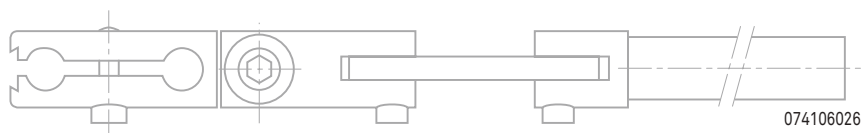

Clamping Attachment

No	=	
074106331	Rectangular clamping attachment complete	

074106331

Reducing Sleeve

No	=	mm
074108942	Reducing sleeve	∅ 8 / ∅ 4

074108942



COMPAC DIAL TEST INDICATORS

Essential for the workshop, but also in the inspection room or measuring laboratory – Ideal for comparative measurement on a surface plate – Detect form and position errors – Measure axial and radial runouts, especially.

Technical Features

- Long measuring travel, up to 3 mm.
- Bidirectional measuring, without reversing lever.
- Same rotation direction of pointers in the two measuring directions (clockwise pointer direction).
- Swivelling probe through 180°.
- Main pivot on self-aligning angular bearings, dimensioned oversize.
- Dovetail mounting machined in the indicator housing.
- Dull chrome-plated bezel and housing.
- Rotating dial.
- Insensitive to magnetic fields generated in mechanical workshops.

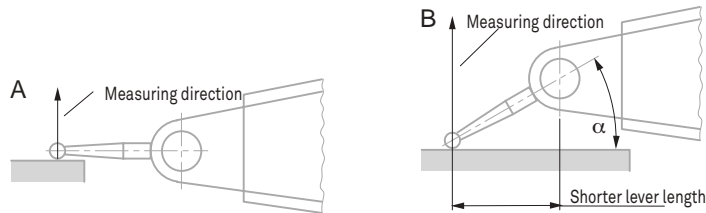

Note for use of COMPAC dial test indicators

With the measuring insert lying parallel to the workpiece surface (Fig. A), these dial test indicators give true reading due to the amplification factor of 1:1. In any other measuring position (angle α in Fig. B), the effective lever length changes. The values indicated need be corrected. In this connection, please consult the instruction manual.



COMPAC Series 210 – Standard Models, Metric

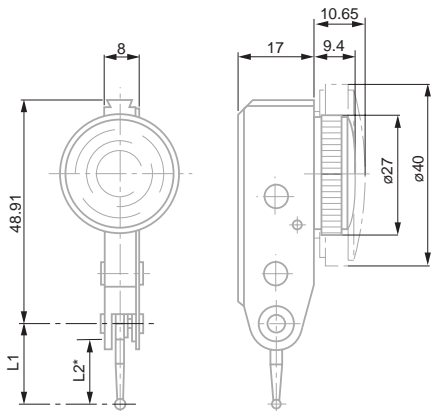

L2; see table of inserts for COMPAC lever-type test indicators

- DIN 2270 and factory standard
- Rotating dial
- Contact points with tungsten carbide ball tips
- Friction lever system to prevent overload
- Supplied in a plastic case, including:
1 contact point, 2 mm dia.
1 rigid stem 8 mm dia., L = 15 mm, No. 01840107
1 rigid stem 4 mm dia., L = 15 mm, No. 01840109 (except for series 220).
- Serial number
- Inspection report with a declaration of conformity

No	Total travel, mm	µm	µm	µm	µm	Travel/revolution, mm	Ø, mm	N	Insert L1, mm	
213	1,5	0,01	13	3	3	0,5	27	0 ÷ 25 ÷ 50	≤ 0,35	18
213G	1,5	0,01	13	3	3	0,5	40	0 ÷ 25 ÷ 50	≤ 0,35	18
212L	3	0,01	26	3	6	1	27	0 ÷ 50 ÷ 100	≤ 0,20	36
212GL	3	0,01	26	3	6	1	40	0 ÷ 50 ÷ 100	≤ 0,20	36
215	0,6	0,002	13	1,5	2,5	0,1	27	0 ÷ 5 ÷ 10	≤ 0,30	18
215G	0,6	0,002	13	1,5	2,5	0,1	40	0 ÷ 5 ÷ 10	≤ 0,30	18
215GL	1,2	0,002	26	1,5	5	0,2	40	0 ÷ 10 ÷ 20	≤ 0,20	36
216G	0,6	0,001	13	1,5	2,5	0,1	40	0 ÷ 5 ÷ 10	≤ 0,30	18

COMPAC Series 220 – Perpendicular Models, Metric

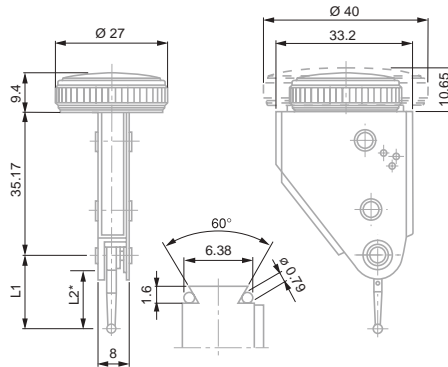

*L2 see table of inserts for COMPAC lever-type test indicators

No	Total travel, mm	µm	µm	µm	µm	Travel/revolution, mm	Ø, mm	N	Insert L1, mm	
223	1,5	0,01	13	3	3	0,5	27	0 ÷ 25 ÷ 50	≤ 0,35	18
223G	1,5	0,01	13	3	3	0,5	40	0 ÷ 25 ÷ 50	≤ 0,35	18
222L	3	0,01	26	3	6	1	27	0 ÷ 50 ÷ 100	≤ 0,20	36
222GL	3	0,01	26	3	6	1	40	0 ÷ 50 ÷ 100	≤ 0,20	36
225	0,6	0,002	13	1,5	2,5	0,1	27	0 ÷ 5 ÷ 10	≤ 0,30	18
225G	0,6	0,002	13	1,5	2,5	0,1	40	0 ÷ 5 ÷ 10	≤ 0,30	18



COMPAC 230 Parallel Models

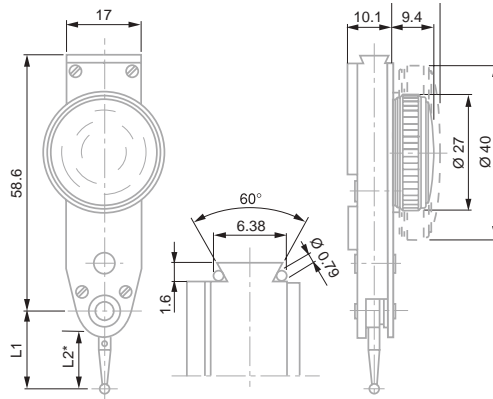

* L1 see table of inserts for COMPAC lever-type indicators

No	Total travel, mm	µm	µm	µm	µm	Travel/revolution, mm	Ø, mm	N	Insert L1, mm
233	1,5	0,01	13	3	3	0,5	27	0 ÷ 25 ÷ 50 ≤ 0,35	18
233G	1,5	0,01	13	3	3	0,5	40	0 ÷ 25 ÷ 50 ≤ 0,35	18
232L	3	0,01	26	3	6	1	27	0 ÷ 50 ÷ 100 ≤ 0,20	36
232GL	3	0,01	26	3	6	1	40	0 ÷ 50 ÷ 100 ≤ 0,20	36
235G	0,6	0,002	13	1,5	2,5	0,1	40	0 ÷ 5 ÷ 10 ≤ 0,30	18



DIN 2270 and factory standard



Rotating dial



Contact points with tungsten carbide ball tips



Friction lever system to prevent overload



Supplied in a plastic storage case, including:
1 contact point, 2 mm dia.
1 rigid stem 8 mm dia., L = 15 mm, No. 01840107,
1 rigid stem 4 mm dia., L = 15 mm, No. 01840109



Serial number



Inspection report with a declaration of conformity

COMPAC 240 Reduced Range Models

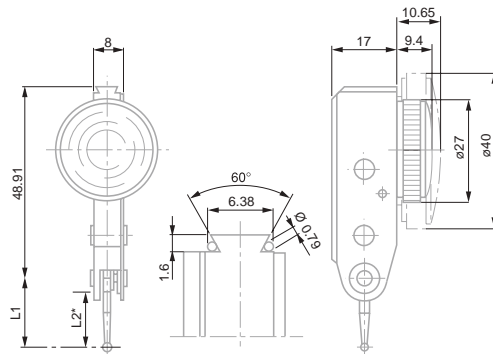

* L2 see table of inserts for COMPAC lever-type indicators

No	Total travel mm	mm	µm	µm	µm	Ø, mm	N	Insert L1, mm
242	0,8	0,01	13	3	3	27	0 ÷ 40 ÷ 0 ≤ 0,25	18
242G	0,8	0,01	13	3	3	40	0 ÷ 40 ÷ 0 ≤ 0,25	18
243L	0,5	0,01	13	3	3,5	27	0 ÷ 25 ÷ 0 ≤ 0,10	45
243GL	0,5	0,01	13	3	3,5	40	0 ÷ 25 ÷ 0 ≤ 0,10	45
245	0,2	0,002	4	1,5	2	27	0 ÷ 10 ÷ 0 ≤ 0,25	18
245G	0,2	0,002	4	1,5	2	40	0 ÷ 10 ÷ 0 ≤ 0,25	18



M1,6 coupling thread



The original inserts mounted on all indicators are fully interchangeable with inserts with different diameter tips as long as the insert has the same nominal length.

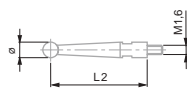

L1 = Axial length from ball to pivot



01866014

Measuring Inserts for COMPAC Models

No	Ball tip, mm	Ball tip material	L1, mm	L2, mm
01866014	0,8	Carbide	18	14,26
01866003	2	Carbide	18	14,26
01866021	3	Carbide	18	14,26
01866016	0,8	Carbide	36	32,26
01866004	2	Carbide	36	32,26
01866023	3	Carbide	36	32,26
01866015	0,8	Carbide	45	41,26
01866006	2	Carbide	45	41,26
01866022	3	Carbide	45	41,26
01866026	2	Ruby	18	14,26
01866027	2	Ruby	36	32,26

Accessories for COMPAC

Swivel Clamps



SPT

No	Stem	Clamping length
SPT	8 mm	25 mm
SPTA	1/4 in	1 in

Mounting Rods with Dovetail Grip

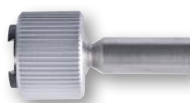

01850106

No		
01850106	Fixing shank swivelling through +/-30°	1/4 in
01850107	Rigid fixing shank	1/4 in
01840106	Fixing shank swivelling through +/-30°	8 mm
01840107	Rigid fixing shank Ø8mm	8 mm
01840108	Fixing shank swivelling through +/-30°	4 mm
01840109	Rigid fixing shank Ø4mm	4 mm





Clamp

No	=	
01860401	Dovetail clamp with tightening screw	mm Ø 5,6 / Ø 9,5



01860401

Mounting Rods

No	=	
01840404	Short swivel holder	mm Ø 8 x 25
01840405	Long swivel holder	Ø 8 x 90
01840406	Angular swivel holder	Ø 8 x 25 (Ø 8 for clamping bore)
01840501	Centering holder	Ø 8 x 25 (Ø 4 for clamping point)
01840407	Long sw. holder, fine adjust	Ø 8 x 125



01840501



01840404



01840405



01840406



01840407

Fixing Shank

No	=	
01840104	Mounting rod	mm Ø 4
01840105	Mounting rod with dovetail clamp	Ø 8
01840202	Cylindrical fixing shank	Ø 8 x 80 (Ø 5,6 for the tenon)
01860008	Mounting rod	Ø 6

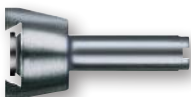

01840104



01840105



01840202

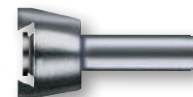

01860008



Comparative Measurement



TESA YA COMPLETE INSTRUMENT SETS

Specially designed for small bores from 0,47 up to 12,20 mm - Checking of dimension and bore form errors through 2-point measuring - Offers an excellent repeatability. The YA bore gauges consist of an interchangeable measuring head with a built-in needle and handle with a 8 mm diameter fixing bore for a dial gauge or any other type of sensor

- Measuring heads with spherical faces for through bores.
- Measuring heads for particularly deep bores.

Can be supplied on request:

- Measuring heads with carbide measuring faces.
- Measuring heads for special applications.
- Measuring heads for blind bores and particularly deep bores with other application ranges.
- Carbide measuring needles.
- Depth extensions 125, 250, 500, 750 and 1000 mm.

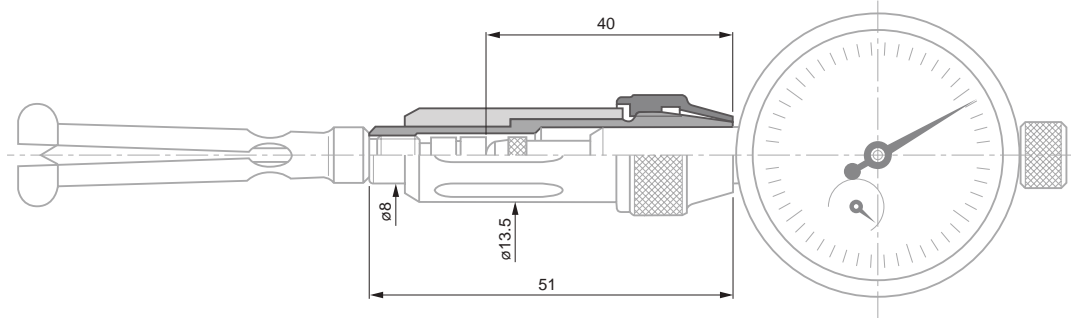
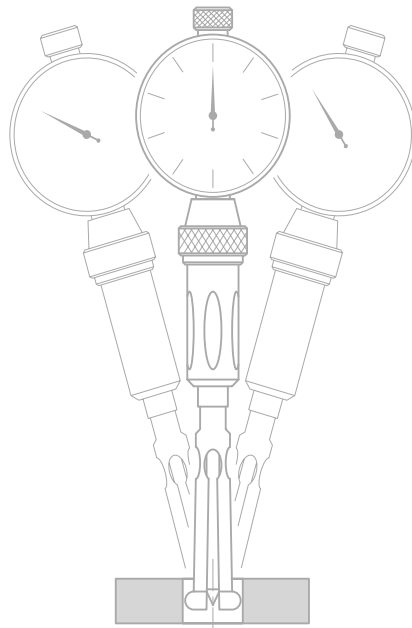

COMPLETE INSTRUMENT SETS FOR MEASURING THROUGH BORES



See table

1 μ m

Reliability of engraved dimension:
 $\pm 2s = 1 \mu$ m

Measuring head in hardened steel and carbide, ≈ 1000 HV 25
Measuring needles in hardened steel, ≈ 800 HV 25
Setting rings: with synthetic sapphire for nominal $\varnothing \leq 1,5$ mm and hardened steel for $> 1,5$ mm, ≈ 780 HV 25

Holder: Mounting of instruments with stem $\varnothing 8$ h6 mm

Technical data: see component sets

Complete set includes:
1 handle No. 01540201.
Measuring heads, needles and setting rings as shown in the table below.
1 TESA COMPACT dial gauge No. 353 (reading to 0,01 mm, $\varnothing 40$ mm dial)
1 Extension for for inserts, 10 mm No. 03540501.

Plastic case

Declaration of conformity



No



mm

01510000	0,47 ÷ 0,97
01510100	0,95 ÷ 2,45
01510200	2,30 ÷ 6,20
01510300	6,00 ÷ 12,20

	No	mm	Measuring depth max. mm	Measuring depth min. mm	No	No	\varnothing
	Measuring heads				Needles	Setting rings mm	
COMPOSITION OF THE SETS:							
01510000	01540401	0,47 ÷ 0,53	1,5	0,25	01540001	01540601	0,50
	01540402	0,52 ÷ 0,58	1,8	0,27	01540001	01540602	0,55
	01540403	0,57 ÷ 0,67	2,0	0,29	01540002	01540603	0,60
	01540404	0,65 ÷ 0,77	2,5	0,31	01540002	01540604	0,70
	01540405	0,75 ÷ 0,87	2,8	0,33	01540002	01540605	0,80
	01540406	0,85 ÷ 0,97	3,0	0,35	01540002	01540606	0,90
01510100	01540407	0,95 ÷ 1,15	11	0,6	01540003	01540607	1,00
	01540408	1,07 ÷ 1,25	11	0,6	01540003	01540608	1,10
	01540409	1,17 ÷ 1,35	11	0,6	01540003	01540609	1,20
	01540410	1,27 ÷ 1,45	11	0,6	01540003	01540610	1,30
	01540411	1,37 ÷ 1,55	11	0,6	01540003	01540611	1,40
	01540412	1,50 ÷ 1,90	17	0,9	01540004	01540612	1,50
	01540413	1,70 ÷ 2,15	17	0,9	01540004	01540613	1,75
	01540414	2,05 ÷ 2,45	17	0,9	01540004	01540614	2,00
					01540615	2,25	
01510200	01540415	2,30 ÷ 2,75	22	1,2	01540005	01540616	2,50
	01540416	2,65 ÷ 3,20	22	1,2	01540005	01540617	3,00
	01540417	3,05 ÷ 3,50	22	1,2	01540005	01540618	3,25
	01540418	3,35 ÷ 3,85	22	1,2	01540005	01540619	3,50
	01540419	3,80 ÷ 4,30	22	1,2	01540005	01540620	4,00
	01540420	4,20 ÷ 5,00	40	2,0	01540006	01540621	4,50
	01540421	4,70 ÷ 5,50	40	2,0	01540006	01540622	5,00
	01540422	5,30 ÷ 6,20	40	2,0	01540006	01540623	5,75
01510300	01540423	6,00 ÷ 6,80	40	2,0	01540006	01540624	6,50
	01540424	6,60 ÷ 7,50	40	2,0	01540006	01540625	7,00
	01540425	7,30 ÷ 8,15	40	2,0	01540006	01540626	7,75
	01540426	8,00 ÷ 8,80	40	2,0	01540006	01540627	8,50
	01540427	8,50 ÷ 9,40	50	2,0	01540006	01540628	9,00
	01540428	9,15 ÷ 10,00	50	2,0	01540006	01540629	9,50
	01540429	9,60 ÷ 10,80	50	3,3	01540007	01540630	10,00
	01540430	10,65 ÷ 12,20	50	3,3	01540007	01540631	11,50



Special Executions

Available upon request :

- Full instrument sets for measuring blind bores and short centering shoulders.
- Measuring heads with tungsten carbide tipped measuring faces.
- Measuring heads for special applications.
- Measuring heads for through bores, particularly deeper ones covering other application ranges.
- Tungsten carbide measuring needles.
- 125, 250, 500, 750 and 1000 mm depth extensions.

Optional Accessories for TESA YA Bore Gauges

Measuring stand for stationary use.



For technical details, see INTERRAPID UA30 measuring supports



Declaration of conformity



01639009 INTERRAPID UA 30 Support

MUST BE EQUIPPED WITH:

01610201 UK 25 sliding arm.
Used with TESA YA for stationary bore measurement on UA30 support.

01640000 UAZ 10 depth stop plate for UA 30



TESA VERIBOR

Proven design and reliability never questioned over decades – Instruments for 2-point measurements for bores from 4,5 up to 550 mm – Detects form errors – Gauge body with a 8 mm diameter clamping bore for a dial gauge, precision indicator or any other sensor.

- Excellent repeatability due to the circular element fixed on the instrument ensuring practically no play.
- Gauge body made of invar steel to neutralise the influence of the operator's hand warmth on the measuring result.
- Centring shoe for correct alignment of the instrument in the bore.
- Tungsten carbide ball tips for high resistance to wear.

TESA VERIBOR Light

Instrument with 2 contact points for comparative measurement of bores and detection of form errors – Automatic self-centering in the bore – Can be used with a dial gauge, a precision indicator or a probe with \varnothing 8h6 clamping stem.



Measuring bolts and anvils in hardened steel, hardness 60 \pm 2 and 63 \pm 3 HRC, respectively

Mounting for sensor with stem \varnothing 8h6

Set including 1 single TESA VERIBOR Light. 1 set of interchangeable fixed inserts covering the entire application range

Wooden case

Declaration of conformity



No	=	Measuring bolt travel, mm	mm	Measuring depth, mm
05710090	TESA Veribor light	1,30	18 \div 35	176
05710091	TESA Veribor light	1,40	35 \div 60	178
05710092	TESA Veribor light	1,40	50 \div 150	178
05710093	TESA Veribor light	1,30 / 1,40	18 \div 150	176 / 178

Sets delivered without dial gauge



TESA VERIBOR



- See table of values
- Only VERIBOR without dial gauge: 2 µm
- Only VERIBOR without dial gauge: ± 2s = 0,5 µm
- Measuring bolts and anvils fitted with carbide ball tips
- Mounting for sensor with stem Ø 8 h6 mm
- Set including 1 single TESA VERIBOR, 1 set of interchangeable fixed inserts covering the whole application range.
- Wooden case
- Declaration of conformity

05710012	4,5 ÷ 6
05710013	6 ÷ 12,5
05710014	12 ÷ 25
05710015	25 ÷ 50
05710016	50 ÷ 150
05710018	50 ÷ 300
05710017	240 ÷ 550

Sets supplied without dial gauges, electronic probes or indicators

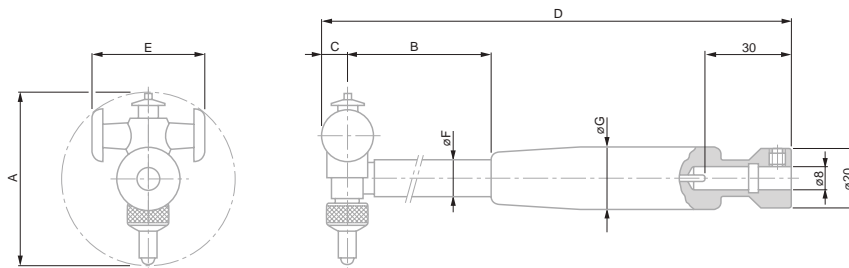

A mm	mm	B mm	C mm	D mm	E mm	F mm	G mm
4,5 ÷ 6	0,35	74	2	138	3,3	3,8	16
6 ÷ 12,5	0,5	93	2,6	156	4,3	4,9	16
12 ÷ 25	0,9	106	4,5	194	7,8	7,9	19
25 ÷ 50	1,3	140	6	228	16	8	19
50 ÷ 150	1,4	173	10	279	36	12	23
50 ÷ 300	1,4	173	10	279	36 / 66	12	23
240 ÷ 550	1,6	227	14	347	112	18	28

Special Versions

Available on request :

- TESA VERIBOR for blind bores and centring shoulders.
- TESA VERIBOR elbow-shaped for hard-to-reach bores.
- Handtools for measuring the distance between two plan-parallel surfaces.
- Handtools for inspecting gear pitch diameters.



ACCESSORIES FOR TESA VERIBOR

Set of Extensions



For extending the application range to \varnothing 300 mm for VERIBOR No. 05710016, 05710058 et 05710065.

		
05740001	Set of extensions	Consisting of – 1 Centring shoe – 3 Extensions 50 mm



Depth Extensions



To be mounted on the body of VERIBOR $\varnothing \geq 25 \leq 550$ mm for large measuring depths (dimension B in the technical drawing of the VERIBOR).

		
05760029	Extension	mm 1000
05760027	Extension	500



Dial Gauge Protection Guard

Protects the dial gauge against direct shocks and prevents the dial from being inadvertently rotated.

		
05760013	Protection guard	mm \varnothing 58



ARM GAUGES

Very practical comparative measuring instrument – Measures at 2 or 3 points depending on the accessory used – Ideal for blind or through bores – also suited for measuring grooves, flutes as well as the internal measurement of parts with parallel faces.

IRA 2 Comparative Gauge

- Large application range from 10 to 150 mm
- Easy to handle thanks to its light weight and ergonomic design
- Built-in indicator with 0,01 mm reading and fine setting
- Centering device for 2-point measurement

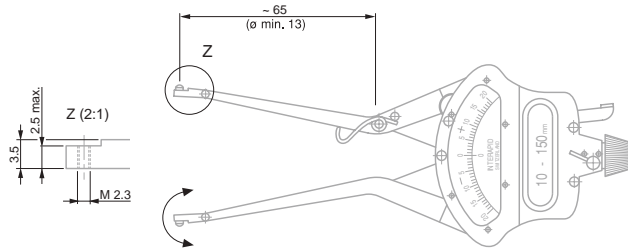
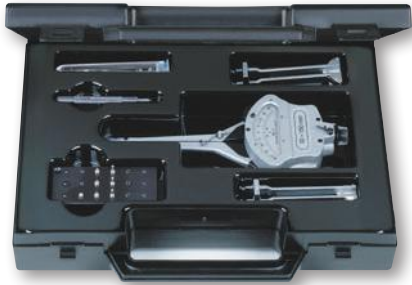

No	=	A
079105704	INTERAPID IRA 2	mm
079111401	INTERAPID IRA 2, carbide	mm
DELIVERED WITH THE FOLLOWING ACCESSORIES:		
079105667	3 inserts, hardened steel (order number for 1 unit, with 079105704)	
079105756	3 inserts, carbide (order number for 1 unit, with 079111401)	
079105668	3 short inserts, hardened steel (order number for 1 unit)	
079105669	3 long inserts in hardened steel (order number for 1 unit)	
079112126	2 inserts, adjustable for internal dia. >6mm	
079110110	Large insert holder for 3-point measurement	
079108502	IRA centering arm, Ø 15-30 mm	
079110111	Small insert holder for 3-point measurement	
079105694	Special screwdriver for IRA set	

Optional Accessories for IRA-2 Comparative Gauge

No	=	
079112051	Small insert set for 3-point measurement	
079112052	Long insert set pour 3-point measuring	

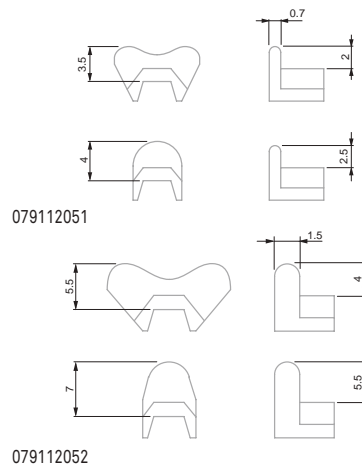
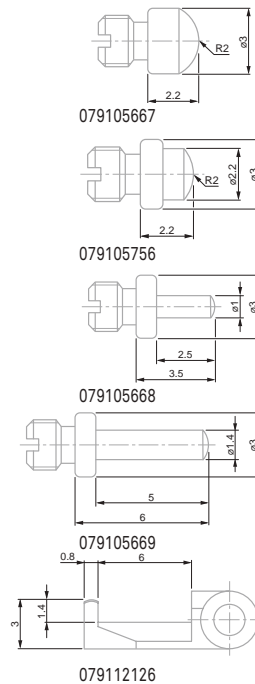
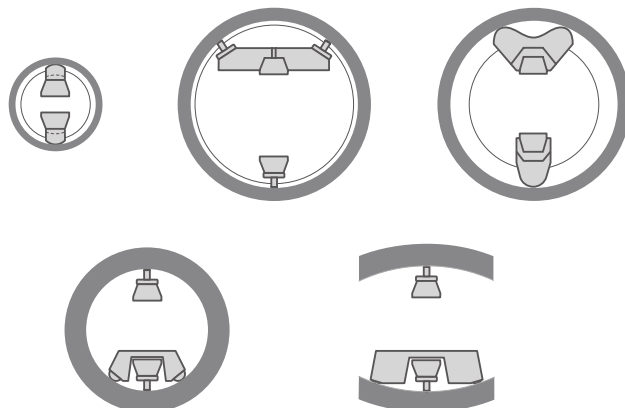

- ± 0,20 mm or ± 0,008 in
- 10 ÷ 150 mm 0.375 ÷ 6 in
- 0,01 mm or 0.0005 in
- Measuring inserts in hardened steel or tungsten carbide, see opposite table
- 3,5 N
- Measuring arm clearance travel: 10 mm
- Plastic case
- Declaration of conformity



- Chrome plated, hardened steel



Ø 57 mm

0,2 mm

Dial gauge: 5 µm

30 mm throat depth.
Highly stable frame
with heat insulating
handle.

≈ 2 N

Non-interchan-
geable measur-
ing inserts. With device
for retraction of
inserts.

Cardboard box

Declaration of
conformity

THICKNESS GAUGES

Designed for the direct measurement of thickness of all types of materials: plastics, glass, wood, felt, paper, rubber, etc.

Each gauge is equipped with a rotating dial for zero setting.

Model for Sheets



074115664 Thickness gauge for sheets

mm
0 ÷ 1

mm
0,001

Flat, mm
Ø 6,35



Ø 57 mm

10 mm

Dial gauge: 40 µm

Interchangeable
measuring inserts

Cardboard box

Declaration of
conformity

Models with Open Inserts When Not in Use



	mm	mm	mm	mm	Paired inserts included
074115604	0 ÷ 30	0,1	50	flat; Ø 30	074115686
074115605	0 ÷ 30	0,1	50	flat; Ø 20	074115687
074115606	0 ÷ 30	0,1	50	flat; Ø 10	074115726
074115607	0 ÷ 30	0,1	50	convex; Ø 10	074115727
074115608	0 ÷ 30	0,1	50	spherical; Ø 5	074115728



INTERAPID SHE.30 & SHE.35 SMALL HORIZONTAL MEASURING BENCHES

Extremely practical and very precise, these measuring benches are mainly used for the inspection of batches of precision parts as used in the watch making and precision mechanical sectors – Rapid measuring and easy setting from one part to the other – Wide choice of measuring inserts specially designed for the most varied of metrology applications.

INTERAPID SHE.30 for External Dimensions



03330004	INTERAPID SHE 30 small measuring horizontal bench for external dimensions (without measuring inserts)
OPTIONAL ACCESSORY:	
03360300	Measuring inserts, carbide, length 3,5 mm, height 0,4 mm

Measuring inserts, either cylindrical or knife-edged are available on request.

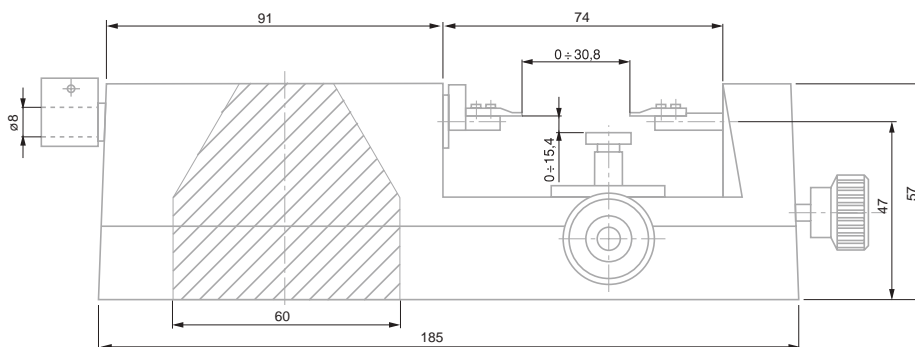

Pair of Measuring Inserts in Special Version

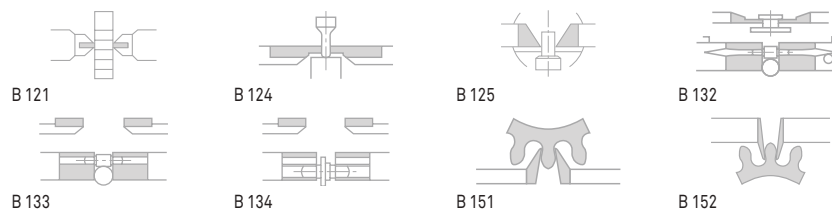

0 to 30 mm



Accuracy is usually influenced by the measuring instrument used as well as both flatness and parallelism of the measuring faces of inserts.

Holder precision: Flatness tolerance of two clamping faces: 0,05 mm. Axial positioning tolerance for the two indexing pins with respect to bolt axis: 0,05 mm. Tolerance for the parallelism of the table surface with respect to the bolt axis: 0,05 mm. See drawing



Main body in cast iron. Other parts in steel, hardened and ground



Produced by sensor used. The SHE.30 model is not spring-loaded.



Mobile measuring bolt: guided on a smooth bearing surface and equipped with a semi-circular disc for bolt retraction. Measuring inserts, assembled in pairs, and mounted on the measuring bolt and fixed anvil with a 1 mm diameter pin and 2 M1,4 screws. Support table with possibility of vertical and longitudinal adjustment: Surface 24 x 9,5 mm. Adjustment range: vertical: 15 mm, longitudinal: 14 mm. With fixing screw. Sensor (not included in the supply for SHE 30 bench): electronic indicator, mechanical or precision dial gauge, axial analogue or digital probe with mounting shank of Ø 8 mm



2,1 kg



Transport packaging



Declaration of conformity

INTERAPID SHE.35 for Internal Dimensions

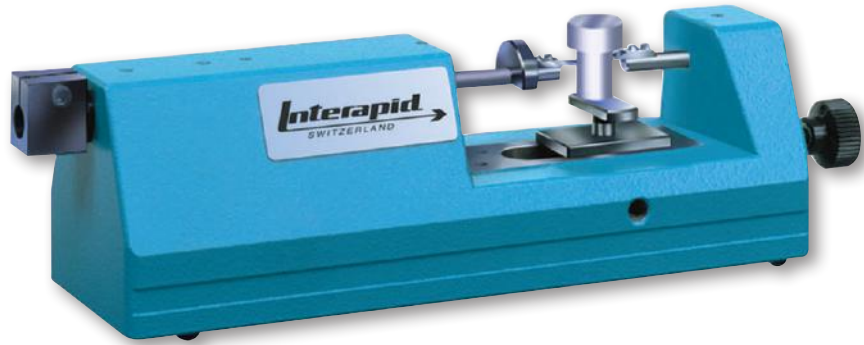

30 mm



8 to 38 mm (standard accessory)



Accuracy is generally influenced by the measuring instrument as well as the type of inserts used.



Main body in cast iron. Other parts in hardened and ground steel. Inserts with carbide measuring faces.



Produced by sensor used. The SHE.35 bench is not equipped with a spring.



Mobile measuring bolt guided on a flat bearing surface, also fitted with a retracting ball-shaped handle. Interchangeable measuring inserts supplied in pairs. Fixing shaft \varnothing 4 mm. Height adjustable support table. Surface: 40 x 70 mm. Setting range: 8 mm. 1 tightening screw. Sensor (must be ordered separately), e.g. dial gauge, electronic or precision indicator, analogue or digital probe. Mounting \varnothing 8 mm.



2,3 kg



Transport packaging



Declaration of conformity



03330006 INTERAPID SHE 35 small horizontal measuring bench for internal dimensions (with measuring inserts)

8 ÷ 38 mm

Inserts with special design also available on request

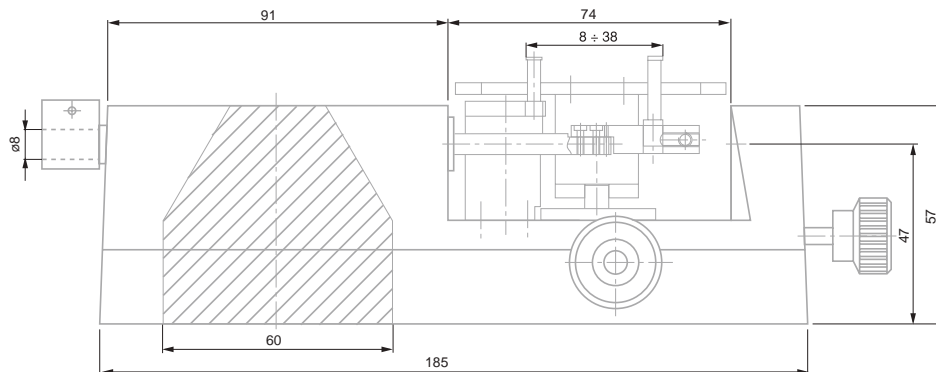





Measuring Supports and Auxiliary Equipment



TESA measuring supports have been designed to offer the best holding stability for instruments such as dial gauges, lever dial test indicators and probes. Stability is the prime requirement needed to reduce the related uncertainties in a measurement method or set-up.





A Base with vee recess and 1 magnetic flat face. Disengageable of magnet possible. Duralumin articulations.



Dovetail clamp with a \varnothing 8 mm clamping bore



0,4 kg



Supplied without indicator



Transport packing



Declaration of conformity

UNIVERSAL SUPPORTS

Magnetic measuring support with suction base or articulated arm.

INTERAPID Magnetic Support with Articulated Arm (small)

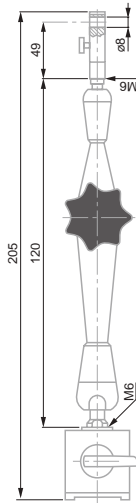

Magnetic support with articulated arm

No	=	Hand	N	H mm	L mm	Base mm	Consisting of:
01639025			≈ 170	205	120	30 x 30 x 30	- 1 articulated arm length 120 mm - 1 dovetail clamp with fine adjustment - 1 magnetic base 30 x 30 x 30 (L x W x H)



A Magnetic base has 1 prismatic and 2 flat faces. Articulations made from duralumin. Disengageable permanent magnet. Dovetail clamp with a \varnothing 8 mm clamping bore.



Supplied without measuring instrument



Suitable transport packing



Declaration of conformity

INTERAPID Magnetic Support with Articulated Arm

Simple and secure locking using a single rotating knob
- highly rigid arm and articulation.

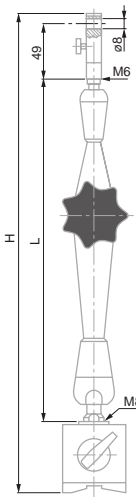

Magnetic support with articulated arm

No	=	Hand	V-Bore for \varnothing , mm	Fine adjust	H mm	L mm	Base mm	Mass kg	Consisting of:
01639022			30 ÷ 150	●	310	200	60 x 50 x 55	1,45	- Articulated arm - Clamp - Magnetic base
01639023			30 ÷ 150	●	390	280	60 x 50 x 55	1,85	- Articulated arm - Clamp - Magnetic base



INTERAPID Magnetic Support with High Precision Articulated Arm

Magnetic support with high precision articulated arm and fine adjustment for measurements that need repeatability in the range of μm .

Simple and secure locking with a two-position knob. Highly rigid arm and articulation.

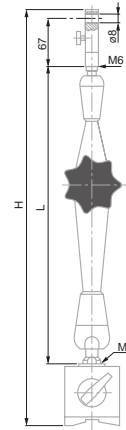

Magnetic support with high precision articulated arm



A Magnetic base has 1 prismatic and 2 flat faces. Articulations made from duralumin. Disengageable permanent magnet. Dovetail clamp with a $\varnothing 8$ mm clamping bore.



Supplied without measuring instrument



Suitable transport case



Declaration of conformity

No	=							
		N	V-Base for \varnothing , mm	Fine adjust	H mm	L mm	Base mm	Consisting of:
01639053	INTERAPID High Precision Magnetic Support with Articulated Arm	≈ 1000	$30 \div 150$	●	440	320	73 x 50 x 55	<ul style="list-style-type: none"> - Articulated Arm - Clamp - Magnetic base

INTERAPID Magnetic Support with Flexible Arm

For measurements in hard to reach locations. Instant and reliable locking through lever control.

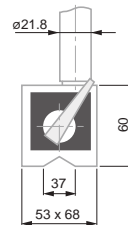

No	=	
01639020	Magnetic Support with Flexible Arm	



Holding force on a flat surface ≈ 1000 N



The magnetic base has 1 prismatic and 2 flat faces. Disengageable permanent magnet. Full length 350 mm. Dovetail clamp with an $\varnothing 8$ mm clamping bore.



Supplied without measuring instrument



Suitable transport packing



Declaration of conformity



A Switchable magnet. Clamp with Ø 8 mm clamping bore

Supplied without measuring instrument

Suitable transport packing

Declaration of conformity

INTERAPID Inclinable Magnetic Support

Standard model and models with strong holding force



01639017



01639019

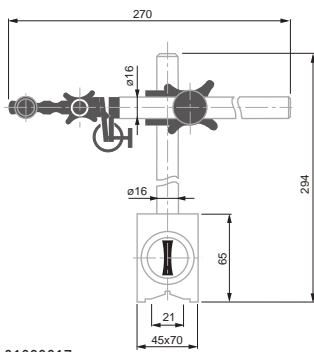

01639017

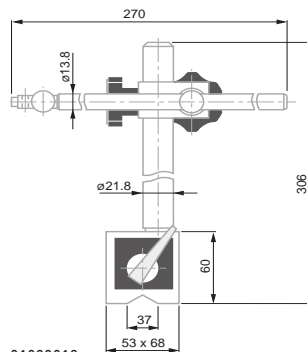

01639018

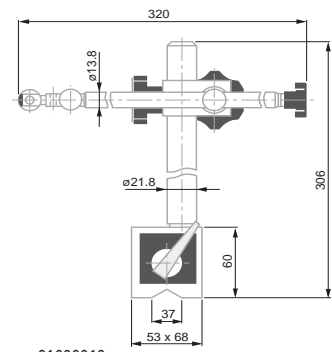

01639019



No	=	N	V-Base for Ø, mm	Standard Version	Fine adjust
01639017	INTERAPID magnetic support with V-base, 600 N	≈ 600	70 ÷ 220	Standard Version	●
01639018	INTERAPID magnetic support with V-base, 1000 N	≈ 1000	70 ÷ 220	Strong magnetic holding force	—
01639019	INTERAPID magnetic support with V-base, 1000 N	≈ 1000	70 ÷ 220	Strong magnetic holding force	●



INTERAPID Support with Suction Base and Articulated Arm

Holds firmly on any smooth and flat surface

- Clamps instantly and reliably using a suction lever switch.
- Highly rigid articulated arm.
- Free from magnetic fields.

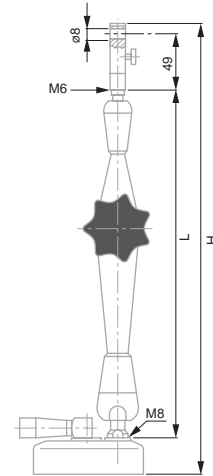

Round suction base made of aluminium (Ø 88 mm, height 28 mm) with flat suction base. Articulations made from duralumin. Suction controlled by lever switch. Dovetail clamp with an Ø 8 mm clamping bore.



1.1 kg



Supplied without measuring instrument



Suitable transport packing



Declaration of conformity



N



Fine adjustment



H, mm



L, mm



Consisting of:

01639024

INTERAPID Measuring support with suction base and articulated arm

≈ 400

●

363

280

- Articulated arm
- Fine adjust clamp
- Round suction base





Measuring table and column in hardened steel.



Measuring arm with \varnothing 8 mm clamping bore, without fine adjustment. Measuring span: 48 mm.



2,7 kg



Supplied without measuring instrument



Suitable transport packing



Declaration of conformity

INTERAPID Small Measuring Support and Table \varnothing 49 mm

Round steel measuring table

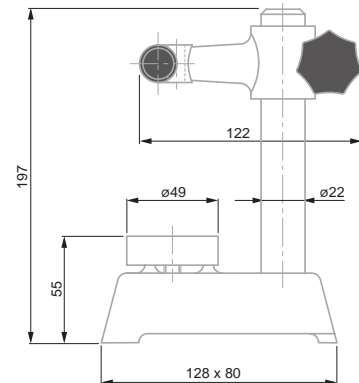

Application example with DIGICO indicator



mm
0 ÷ 100



mm
49

01639006 INTERAPID small support with \varnothing 49 mm measuring table

INTERAPID Measuring Support with Inclined Frontal Arm



Cast iron base



Base with front support face. Clamp for \varnothing 8 mm mounting rod or dial gauge with lug back. Model No 01639003 also with dovetail clamp.



1,3 kg (01639003)
4,35 kg (01639004)



Supplied without dial gauge



Packed suitable for transport



Declaration of conformity



01639003

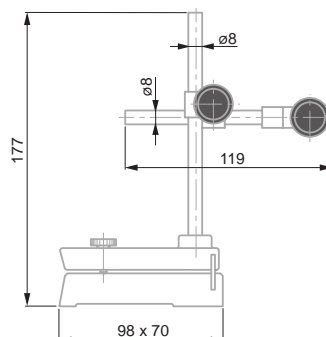

01939003



01639004

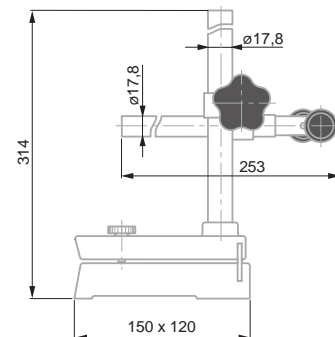

01939004



01639003 INTERAPID Measuring Support with Inclined Frontal Arm H = 177 mm

01639004 INTERAPID Measuring Support with Inclined Frontal Arm H = 314 mm

Used in conjunction with:
Lever dial test indicators, small dial gauges
Lever dial test indicators, small dial gauges, precision indicators, probes etc.



INTERAPID UA 1 Table Measuring Support with Ground Table Surface

Basic model without fine adjustment

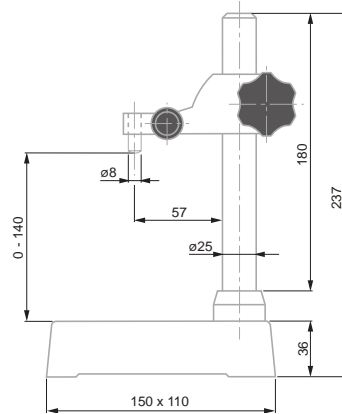

01639008	INTERAPID UA 1 measuring support with table	0 ÷ 140	100 x 100



Measuring table: cast iron. Column: chrome-plated steel, Arm: spherical graphite cast iron.



Measuring surface of table: ground. Column: Can be dismantled. Measuring arm with Ø 8 mm clamp.



3 kg



Supplied without measuring instrument



Suitable transport packing



Declaration of conformity

INTERAPID UD12 Support

Medium sized mobile measuring support for use with ever type dial test indicators, dial gauges, precision indicators, electronic probes etc.

With fine adjustment mechanism.

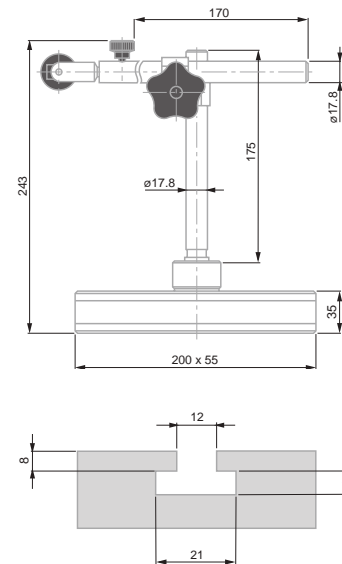

01639000	UD 12 universal support		
COMPOSÉ DE:			
01840105	Tige de fixation à queue d'aronde Ø 8 mm		
01640100	UDZ 3 Mounting rod and UDZ3 clamp Ø 8 mm clamp for UD 12		



Cast iron base



Stand with lateral guiding faces. T-slot for vertical column. 2 rigid articulations



3.3 kg



Supplied without measuring instrument



Suitable transport packing



Declaration of conformity



INTERAPID Table Measuring Stands with Granite Grade 00



3 µm in accordance with DIN 876 T1, class 00



01639035: black burnished column with Ø 8 mm clamping bore.

01639029: chrome plated column with thread and threaded ring for adjusting the height of the measuring arm. Ø 8 mm clamping bore. Grooved measuring face.

01639030: Chrome plated column. Tilting measuring arm and joint. Ø 4 mm or 8 mm bore for a dovetail clamp or lug.

01639033: Chrome plated column. Horizontal sliding arm. Ø 4 mm or 8 mm bore for a dovetail clamp or lug.



Supplied without measuring instrument



Suitable transport packing



Declaration of conformity

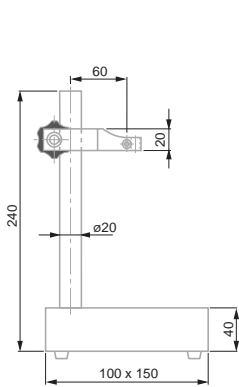

01639035

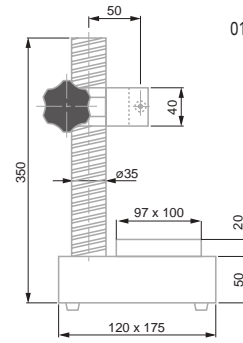

01639029

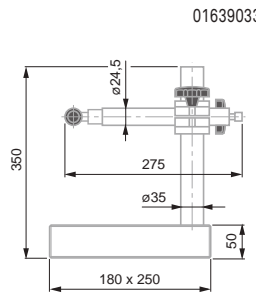

01639033



No	=									
		mm	mm	Measuring surface	Fine adjustment	Measuring table mm	Column height mm	Working surface mm	Span mm	kg
01639035	Table measuring support with granite, column Ø 20	0 ÷ 170	20	Granite	–	100 x 150 x 40	200	100 x 115	50,0	2,6
01639029	Slotted table measuring support with granite, threaded column Ø 35	0 ÷ 225	35	Hardened steel	●	120 x 175 x 50	300	100 x 100	68,5	8,1
01639033	Table measuring support with granite, column Ø 35	0 ÷ 260	35	Granite	●	180 x 250 x 50	300	180 x 200	Adjustable	10,5



SMALL MAGNETIC SUPPORTS

Ideal for lever type dial test indicators, and dial gauges up to 40 mm diameter
- With 2 articulation joints and fine adjustment.

UJ 15 Model

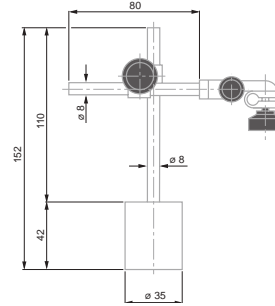

01639007 Magnetic support INTERAPID UJ15, dovetail clamp and $\varnothing 8$ mm cylindrical clamping

UJ 15G Model

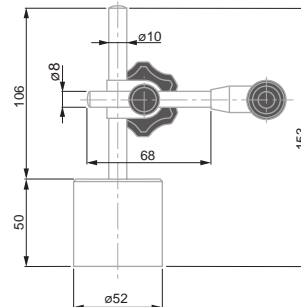

01639016 UJ Magnetic support

Accessories for Small Magnetic Stands



01640501 Steel base plate for UJ15 or UJ15G that become movable



Holding force on a flat surface: ≈ 220 N



Rounded base with permanent magnet



0,47 kg



Supplied without indicator



Packed suitable for shipping



Declaration of conformity



Holding force on a flat surface: ≥ 350 N



Rounded base with permanent magnet



0,93 kg



Supplied without indicator



Packed suitable for shipping



Declaration of conformity



50 x 80 x 20 mm



0,60 kg



Cast iron table.
Chrome plated steel
column



Suitable transport
packing



Declaration of
conformity



Support base:
Ground measuring
face. 2 T-slots. Re-
movable column.



Supplied without
sensor



Support base only:
4,85 kg
Measuring arm:
0,85 kg
Sliding arm: 1,75 kg

UA 30 MEASURING STAND

Base for mounting special fixtures adapted for series inspection

INTERAPID UA 30 Measuring Stand, Without Measuring Arm

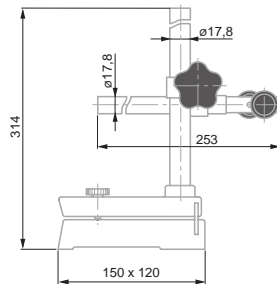

01639009

INTERAPID UA 30 measuring support with
table, without measuring arm

0 ÷ 175

0 ÷ 6.89

125 x 115



Measuring arm
01610200: With
fine adjustment. 1
mm travel. Ø 8 mm
clamping bore.
Sliding arm
01610201: Sliding
holder for TESA
YA dial gauges.
Adjustable swinging
movement. Clamp-
ing bore Ø 13 mm.
Length of travel
35, 57 or 80 mm.
Measuring span
60 mm. Depth stop
plate 01640000:
Dimensions: 115 x
35 x 3,5 mm.
120° vee recess for
Ø ≤ 120 mm, 2 tight-
ening screws.

Accessories for UA 30



01610200



01610201

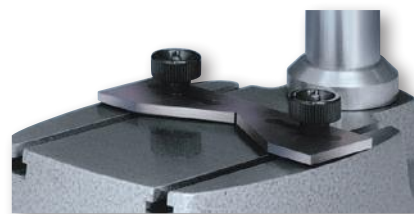

01640000



01610200

UK 20 measuring arm with fine adjustment for UA30 support

01610201

UK 25 sliding arm. Used with TESA YA for stationary bore measurement on UA30 support

01640000

UAZ 10 depth stop plate for UA 30



EQUIPEMENT AUXILIAIRES

INTERAPID Depth Foot with a Flat Face



No	=		
01639046	Depth foot with flat face	mm	mm
		80 x 16	8

INTERAPID Depth Foot with Prismatic Measuring Face

For measuring the depth of key slots on cylindrical shafts and determining circularity errors etc.



No	=						
01639047	Depth foot with prismatic measuring face	Diameter mm	Diameter in	Width mm	Width in	Clamp mm	Clamp in
		10 ÷ 100	0.39 ÷ 3.9	16	0.64	8	0.315

Brown & Sharpe CENTER FINDER Centering Tool

Practical for aligning the centre of a bore with respect to the spindle axis of a machine tool

- Without the clamping shaft, it can also serve as small magnetic support
- Allows the clamping of a dial test indicator, either a standard or perpendicular model.



No	=
06769006	B&S CENTER FINDER centering tool



Hardened steel



Lapped measuring faces. Clamp with lock for mounting a dial gauge or probe



Supplied without sensor



Suitable transport packing



Declaration of conformity



Hardened steel



Lapped measuring faces. Clamp with lock for mounting a dial gauge or probe



Supplied without sensor



Suitable transport packing



Declaration of conformity



Center Finder consisting of the following components:

- cylindrical shank for clamping on the chuck of a machine tool.
- powerful round magnetic base with strong holding capacity.
- swivel joint and dovetail collar for clamping a lever-type dial test indicator.



Wooden case



Hardened steel



Ground finish for support and vee faces



Not available as individual components



Suitable transport packing

Brown & Sharpe V-Block Set with Clamping Bridge

V-blocks with frames for clamping cylindrical parts diameters ranging from 0,7 to 40 mm.

Can be used for machining or inspecting workpieces

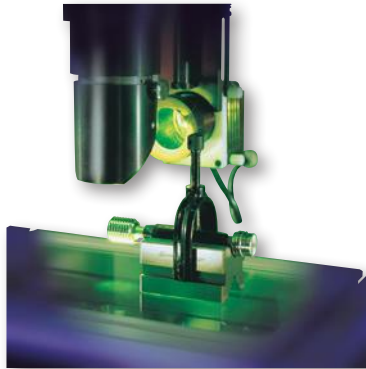

No	=	∅	∅	📦	Consisting of:	
		Clamping Range, mm	Clamping Range, in			
06769007	Set of B&S V-blocks	0,7 ÷ 40	0.3 ÷ 9/32		1 pair of V-blocks	5 ÷ 40 mm
					1 extra V-block	3 ÷ 8 mm
					1 extra V-block	1,5 ÷ 5 mm
					5 extra V-blocks	0,7 ÷ 3,5 mm
					2 in-between bridges	
					2 large frames	
					1 small frame	



7 µm for each pair



2,5 µm for the 6 faces



Hardened steel, 55 to 60 HRC



Each block has 18 through bores Ø 9,53 mm and 5 bores with M10 threads



Supplied with five M10 socket head screws and one 8 mm socket wrench



Plastic case

Brown & Sharpe Positioning Block Set

Pair of matched blocks used for positioning and holding workpieces or for use as stops on granite surface plates, a coordinate measuring set-up, a machine-tool or other applications - Each block are precision ground.



No	=	mm	in
06769004	Positioning block set, precision ground	75 x 50 x 25	2.95 x 1.95 x 0.98



Brown & Sharpe Adjustable Parallels

Set consists of 6 adjustable parallels.

Used as parallel pads, setting standards for measuring instruments or gauges for checking internal dimensions on parallel surfaces.

Each parallel consists of two tapered parts dovetailed together. – Two tightening screws lock the parallels to the size required.



Hardened steel



Supplied with a PH 1 screwdriver



Plastic pouch

No	=			
06769010	Adjustable parallel set			
Consisting of:				
=	⚙	⚙		
	Height mm	Length mm	Width mm	
1 parallel	10 ÷ 13	44	7	
1 parallel	13 ÷ 17	54	7	
1 parallel	17 ÷ 24	68	7	
1 parallel	24 ÷ 33	90	7	
1 parallel	33 ÷ 44	106	7	
1 parallel	44 ÷ 57	129	7	



ROCH Flexible Rules

In spring stainless steel - Divisions of 1 mm and 0.5 mm.



Class CE II



Stainless spring-loaded steel



Suitable transport packing



Declaration of conformity



No	=	⚙	⚙	⚙
		Length mm	Width mm	Thickness mm
0951750181	ROCH flexible rule L = 200 mm	200	13	0.5
0951750182	ROCH flexible rule L = 300 mm	300	13	0.5
0951750184	ROCH flexible rule L = 500 mm	500	18	0.5
0951750187	ROCH flexible rule L = 1000 mm	1000	18	0.5

- Length L = 100 mm, Width = 13 mm max.
- Alloyed steel
- Blades not supplied individually
- Plastic pouch
- Declaration of conformity

ROCH Thickness Gauges



No	=				
		Thickness mm	Incrément mm	Thickness in.	Number of blades
0951753013		ROCH thickness gauge with 13 blades, 0,05 to 1,0 mm	0,05 ÷ 0,3 / 0,4 ÷ 1,0	0,05 / 0,1	0.001968 ÷ 0.003937 / 6/7
0951753014		ROCH thickness gauge with 20 blades: 0,05 to 1,0 mm	0,05 ÷ 1,0	0,05	0.001968 ÷ 0.003937 / 20
0951753015		ROCH thickness gauge with 21 blades; 0,1 to 0,2 mm	0,1 ÷ 2,0	0,1 + 1 x 0,05	0.003937 ÷ 0.07874 / 21

ROCH Radius Gauges

Set of radius gauges with concave and convex blades. Designed for visual inspection of radii.



- Stainless steel
- Blades are not supplied individually
- Plastic pouch
- Declaration of conformity

No	=					
		Radius mm	Radii mm	Incrément mm	Number of blades	
0951753001		ROCH Radius Gauge 2 x 17 blades	0,1	1,0 ÷ 2,75 / 3,0 ÷ 7,0	0,25 / 0,5	2 x 17
0951753002		ROCH radius gauge 2 x 16 blades	0,15	7,5 ÷ 15,0	0,5	2 x 16
0951753003		ROCH radius gauge 2 x 15 blades	0,2	15,5 ÷ 19,5 / 20,0 ÷ 25,0	0,2	2 x 15

ROCH Screw Pitch Gauges

60° flank angles for ISO metric threads or 55° for Whitworth threads.



- Alloyed steel
- Blades are not supplied individually
- Plastic pouch
- Declaration of conformity

No	=				
		Thread pitch mm	Threads per in	Metric thread	
0951753045		ROCH screw pitch gauge for ISO 60° threads	0,25 / 0,3 / 0,35 / 0,4 / 0,45 / 0,5 / 0,6 / 0,7 / 0,75 / 0,8 / 0,9 / 1,0 / 1,25 / 1,5 / 1,75 / 2,0 / 2,5 / 3,0 / 3,5 / 4,0 / 4,5 / 5,0 / 5,5 / 6,0	-	ISO 60° mm
0951753046		ROCH screw pitch gauge - Whitworth 55° threads	62 / 60 / 48 / 40 / 36 / 32 / 30 / 28 / 26 / 25 / 24 / 22 / 20 / 19 / 18 / 16 / 14 / 13 / 12 / 11 / 10 / 8 / 7 / 6 / 5 / 4,5 / 4	-	Whitworth 55° (threads per inch)



ROCH Portable Magnifier

With a folding handle and additional magnifier. – Retractable support.



Solid resistant plastic



Cardboard box



Declaration of conformity

No	=				
		Large magnifier	Small magnifier	mm	Small magnifier, mm
0951754511	ROCH portable magnifier	3x	10x	80 x 45	13



Straightness, Angle and Inclination Measurement



INCLINOMETERS AND PRECISION LEVELS

Irrespective of whether they are spirit or electronic inclinometers, all precision levels are based on the same perfectly reliable reference but also cost-free: the centre of the earth's gravity.

Under the force of gravity, the gas bubble in the liquid or the pendulum inclines itself according to this natural physical principle.

The position of the pendulum with respect to the measuring faces of the instrument body can then be measured. Based on this perfect principle, these instruments offer a great number of measuring applications of high precision. The horizontal and vertical positioning of the measuring faces enable the detection of form errors in the geometrical elements on the workpiece to be measured.

These errors often result from deviations in straightness, flatness, position, parallelism and squareness.

Indication of values may vary depending on the type of level, the values typically displayed are:

- inclination (mm/m or in/10 in);
- radian in mrad;
- decimal angle (e.g. 12,37°);
- sexagesimal angle in degrees (°), minutes (') and seconds (") e.g. 15° 30' 45".



TESA MICROBEVEL 1



TESA CLINOBEVEL
1 USB



TESA CLINOBEVEL 2



TESA NIVELTRONIC



Spirit clinometers with
angle protractor



INCLINOMETERS AND LEVELS

The TESA inclinometers and levels meet the most demanding applications not only in the machine building sector but also in the civil construction sector.

Electronic Inclinometer - TESA CLINOBEVEL 1 USB

Compact universal instrument for direct and differential measurements – Measuring range $\pm 45^\circ$ with display of measured angles or inclinations – Reinforced aluminium housing, eloxide surface – Large digital display for error free interpretation of readings.

Supplied with CLINOSOFT software permitting the visualisation and storage of measurements as well as the USB cable to host computer.

Multiple applications are possible, notably the measurement of 2 flat surfaces by comparing the measured values with the help of 2 instruments. Automatic generation of inspection reports using Microsoft EXCEL spreadsheet software.



CLINOSOFT Software



Measuring functions: A ; B ; A+B ; A-B



CLINOSOFT Software

CLINOBEVEL 1-USB, can be used on its 4 faces.

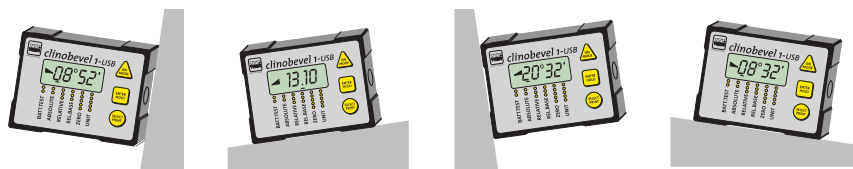

- DIN 2276 Part 2 (Form D)
- LCD angle display: Decimal or sexagesimal
Inclination mm/m, in/10 or 12 in, mm or in/basis length, radian (mrad) and the like
- Capacitive measuring system with gravity pendulum
- 2' + 1 numerical interval
- 21 storable correction values (high accuracy)
- Flat face 4 x 90°
- 100 x 75 x 35 mm
- Anodised light alloy
- Response time ≈ 1 s
- Automatic shut down after 8 min
- Display lock
- RS485, asynchronous, 7 bits, 2 stop bits, no parity, 9600 bauds
- 1 1,5 V battery, type LRC 6, AA
- ≈ 150 hours
- 0 to 40°C
- 20 to 70°C
- IP65 (IEC 60529)
- EN 50081-1 / -2
EN 50082-1 / -2
- 0,52 kg
- Plastic case
- Identification number
- Inspection report with declaration of conformity

05330203	CLINOBEVEL 1 USB electronic inclinometer	$\pm 45^\circ$	$\geq 0,02$	mm/m mm	Livré avec: CLINOSOFT software plus USB cable to host computer

- OPTIONAL ACCESSORIES:**
- 04768002 4 batteries LRC 6 AA, 1,5 V for CLINOBEVEL 1 USB, CLINOBEVEL 2, MICROBEVEL,
 - 05360006 External switch with cable, L = 2 m, for CLINOBEVEL 1 USB
 - 05360014 External switch, wireless, for CLINOBEVEL 1 USB

TESA CLINOBEVEL 2 Electronic Inclinometer

Portable precision inclinometer.

Measuring range $\pm 45^\circ$ with indication of angle or inclination.

Integrated temperature compensation 2 prismatic measuring faces.

Spirit level integrated in transverse direction to eliminate "twist" error.

Simple and rapid calibration: correction of gain by the 3-point method and software integrated in the instrument.

Microprocessor-based features for display setting and instrument adjustment.

The CLINOBEVEL 2 can be used on its two reference faces.

It can also be connected to a second CLINOBEVEL 2 instrument for a differential measurement (Comparative): one of the two instruments operates as a reference without the need to connect to a computer.

The integrated RS 232 interface enables the connection of the instrument to a computer.

Magnetic inserts can be integrated on the measuring faces on request as a special execution.



When 2 CLINOBEVEL 2 are connected, one of the instruments becomes the reference

- DIN 2276 Part 2 (Form D)
- LCD angle display: Decimal or sexagesimal Inclination mm/m, in/10 or 12 in, mm or in/ basis length, radian (mrad) and the like
- Capacitive measuring system with gravity pendulum
- $10'' \pm 0,03\%$ of the readout
- 2 flat measuring faces with V-slot for diameters from $\varnothing 17$ to 94 mm
- 150 x 150 x 35 mm
- Rust inhibiting housing
- Response time: < 5 s
- Automatic shut down after 8 min
- RS 232 asynchronous. 7 bits, 2 stop bits, no parity, 9600 bauds
- 2 batteries 1,5 V, type LRC 6, AA
- 40 to 60 hours
- 0 to 40°C
- 20 to 70°C
- IP65 (IEC 60529)
- EN 50081-1 / -2 EN 50082-1 / -2
- 3 kg
- Plastic case
- Identification number
- Declaration of conformity

05330202	Electronic Inclinometer TESA CLINOBEVEL 2	$\pm 45^\circ$	$\geq 5''$ (5 Arcsec = 0,025 mm/mm)	mm 100 x 150 x 35
OPTIONAL ACCESSORIES:				
04768002	4 batteries LRC 6 AA, 1,5 V for CLINOBEVEL 1 USB, CLINOBEVEL 2, MICROBEVEL,			
05360004	Connecting cable between 2 CLINOBEVEL 2, L = 2,5 m			
S53070174	Câble USB pour CLINOBEVEL 2, L=2,5 m			



DIN 2276 Part 2 (Style D)

See table for max. perm. errors

LCD display according to table

Fully encapsulated measuring system with gravity pendulum

See table for max. perm. errors

2 flat measuring faces with V-slot for diameters from 20 to 120 mm

Cast iron base. Chromium plated side faces. Aluminium housing, lacquered

Response time < 3 s

Automatic shut down after 55 min

1 mV per unit (100 kΩ)

1,5 V battery, type LRC 6, AA

100 to 140 hours

≤ 0,1 %/°C based on the measuring range at 20 ± 5°C

0 to 40°C

-20 to 70°C

EN 50081-1 / -2 EN 50082-1 / -2

According to table, inclusive case

Plastic case

Identification number

Declaration of conformity

TESA MICROBEVEL 1 Inclinometer

TESA MICROBEVEL 1 is particularly suited for measuring slightly inclined surfaces such as the measuring of flatness of surfaces or the geometrical characteristics (deviation, rotation etc.) of a machine tool.

Suited for operation under the most rugged conditions., protected by an aluminium case.

Power supplied by a single standard battery AA 1,5 V for at least 100 hours of operation.



Horizontal model



Square model

Models with steps 0,05 to 0,005 mm/m available on request

No	=	Range 1 or Range 2, mm/m	Base width, mm	Base height, mm	kg (with transport case)
05330003	TESA MICROBEVEL 1 horizontal base 110 x 45 mm	0,01 ou 0,001	110	45	1,8
05330004	TESA MICROBEVEL 1 horizontal base 150 x 45 mm	0,01 ou 0,001	150	45	2,1
05330005	TESA MICROBEVEL 1 square base 150 x 45 mm	0,01 ou 0,001	150	45	3,1
OPTIONAL ACCESSORY:					
04768002	4 batteries LRC 6 AA, 1,5 V for CLINOBEVEL 1 USB, CLINOBEVEL 2, MICROBEVEL,				

Range	mm/m	mm/m	mm	G = mm/m
1	± 20	± 5	0,01	Flatness ≤ 5 mm/m G = 1 % of the measured value and min. 0,01 mm/m
2	± 2	± 2	0,001	Flatness ≤ 1 mm/m G = 1 % of the measured value and min. 0,001 mm/m



TESA NIVELTRONIC Electronic Levels with Analogue Display and Integrated Galvanometer

Electronic levels with analogue display and integrated galvanometer. These instruments are known for a remarkable stability at zero point. They are used for the inspection and alignment of horizontal and vertical surfaces. They are also suitable for the measurement of slight inclinations, specially for the inspection of flatness of granite surface plates.

The square model is particularly suited for the measurement of flat or cylindrical parts thanks to its prismatic base.



NIVELTRONIC square model with 2 prismatic bases



NIVELTRONIC horizontal model with flat base



NIVELTRONIC horizontal with granite base

No	=	mm/m	Base length mm	Base width mm	kg
03130063	TESA NIVELTRONIC electronic level, horizontal, analogue display	0,05 / 0,01	150	45	6,0 / 3,7 *
03130060	TESA NIVELTRONIC electronic level, square, analogue display	0,05 / 0,01	200	45	6,5 / 4,4 *

* With/without wooden case

OPTIONAL ACCESSORIES:

03160007	Granite base 200 x 50 mm for horizontal NIVELTRONIC**
03160008	Granite base 250 x 50 mm for horizontal NIVELTRONIC**
03160009	Granite base 500 x 50 mm for horizontal NIVELTRONIC**
03160048	Holder with voltage regulator (4,65 V) and 4x LR03 AAA for NIVELTRONIC
04761059	4 batteries LR03 AAA, 1,5 V for NIVELTRONIC

** For horizontal model

Range	mm/m	"	mm/m	"
1	± 0,75	± 150"	0,05	10"
2	± 0,15	± 30"	0,01	2"



DIN 2276 Part 2 (Style D)



See table



See table



Inductive measuring system with gravity pendulum



As per DIN 2276: up to 0,5 * measuring range: min. 0,001 mm/m, max. 1 % of the measured value from 0,5 * measuring range: max. 1 % of (2 * measured value - 0,5 * total range.)



1 µm/m



Horizontal model with a flat measuring face. Square model with 2 flat faces having a V-slot for Ø from 20 to 120 mm



Cast iron body. Horizontal model with granite base.



≈ ± 0,2 V, impedance 4,5 kΩ



4 batteries AAA 1,5 V



10 to 30°C



-20 to 60°C



EN 50081-1 / -2 EN 50082-1 / -2



Wooden case



Identification number



Declaration of conformity



DIN 2276/1 (instrument) DIN 877 (graduation)



See table



DIN 2276/1



Mounting with 2 or 3 screws



Cardboard box



Declaration of conformity

TESA Crossed Spirit Levels – for Assembly

For the inspection and alignment of flat surfaces.

The 2 vials permit a simultaneous alignment in the X and Y axes.
The level can be screwed on to a surface.



Model B: Circular level with cross vials, 3-point mounting. Aluminium alloy protection case, anodised.



Model C: T-shaped level with cross vials, 2-point mounting. Manually lapped measuring base to ensure a much higher precision of the level.

No	=		A	I x L mm	∅ mm	H mm
05331500	Level, 2 vials, 2 to 5 mm/m, ∅ 40	2 ÷ 5	B, Circular level with 2 vials, 3x M2, 35 g (level only)		∅ 40	11
05331502	Level, 2 vials. 0,3 mm/m, 0,3 ∅ 60		B, Circular level with 2 vials, 3x M4, 85g (level only)		∅ 60	13
05331550	Level, 2 vials; 0,1 mm/m, 0,1 80 x 65 mm		C, T-shaped level with 2 vials, 2x M5, 250 g (level only)	80 x 65		17
05331551	Level, 2 vials; 0,3 mm/m, 0,3 80x65 mm		C, T-shaped level with 2 vials, 2x M5, 250 g (level only)	80 x 65		17



TESA Precision Spirit Levels

For checking and aligning flat or cylindrical surfaces in the horizontal position.

With an adjustment system for zero point and "twist" error.

Prismatic measuring base, manually lapped finish, enabling a higher precision for the level.

Insulating grip in wood essential for reducing heat transfer due to manual handling.

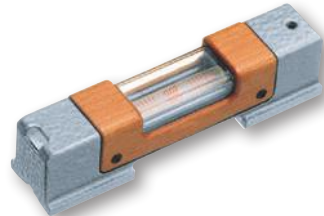

Model B: horizontal precision level

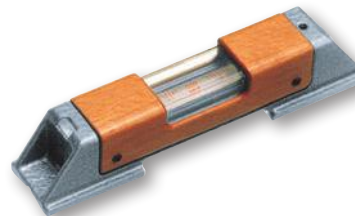

Model C: horizontal precision level

No	=		A	For shafts Ø, mm	mm
05331050	Precision spirit level 0,02, L = 100 mm	0,02	B, 0,35 kg (level only)	17 ÷ 84	100 x 32 x 35
05331054	Precision spirit level 0,02, L = 150 mm	0,02	B, 0,65 kg (level only)	17 ÷ 94	150 x 35 x 38
05331058	Precision spirit level 0,02, L = 200 mm	0,02	C, 0,95 kg (level only)	19 ÷ 108	200 x 40 x 42
05331061	Precision spirit level 0,1, L = 200 mm	0,1	C, 0,95 kg (level only)	19 ÷ 108	200 x 40 x 42
05331063	Precision spirit level 0,02, L = 250 mm	0,02	C, 1,3 kg (level only)	19 ÷ 120	250 x 45 x 42

TESA Precision Spirit Levels with a Frame

For checking and aligning flat or cylindrical surfaces in horizontal and vertical positions.

Instrument features: 4 measuring faces, 2 prismatic faces (shafts Ø 17 to 135 mm) et 2 smooth flat faces.

With adjustment system for zero point and "twist" error.

Longitudinal vial with sensitivity of 0,02 to 0,1 mm/m, depending on the model.

Side viewing slots for an excellent visibility of the top and side of the main vial.

Cross vial with sensitivity of 2-5 mm/m for easy adjustment.

3 insulating grips to avoid any thermal transfer.

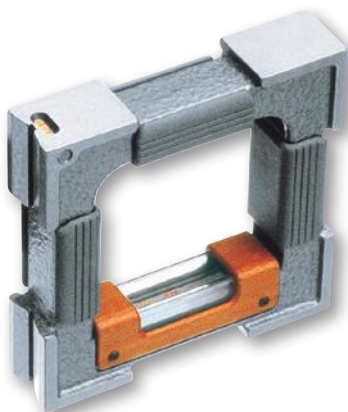

No	=		For shafts Ø, mm	mm
05331201	Precision spirit level with frame, 0,05/100 x 100 x 32 mm	0,05	17 ÷ 84	100 x 100 x 32
05331202	Precision spirit level with frame, 0,1/100 x 100 x 32 mm	0,1	17 ÷ 84	100 x 100 x 32
05331204	Precision spirit level with frame, 0,05/150 x 150 x 35 mm	0,05	17 ÷ 94	150 x 150 x 35
05331206	Precision spirit level with frame, 0,02/200 x 200 x 40 mm	0,02	19 ÷ 108	200 x 200 x 40
05331210	Precision spirit level with frame, 0,05/250 x 250 x 45 mm	0,05	19 ÷ 120	250 x 250 x 45

- DIN 877
- See table
- DIN 2276 Part 1
- Flat and prismatic measuring faces
- Longitudinal and cross level vials
- Wooden case
- Declaration of conformity

-
- DIN 877
- See table
- DIN 2276 Part 1
- 4 x 90° flat measuring faces, machined together, 2 of them with V-shape grooves
- Longitudinal and cross vials
- Wooden case
- Declaration of conformity

- DIN 877
- See table
- DIN 2276 Part 1
- Two flat measuring faces machined as a set (90°), v-shaped groove
- Longitudinal and cross vials
- Wooden case
- Declaration of conformity

TESA Precision Spirit Levels, Square Models with Magnetic Inserts

For inspecting and aligning flat or cylindrical surfaces in horizontal and vertical positions.

Instrument features: 2 prismatic faces (shafts \varnothing 19 to 108 mm) with the vertical measuring face having magnetic inserts.

Equipped with an adjustment system for zero point and "twist" error.

Longitudinal vial with a sensitivity from 0,02 to 0,05 mm/m, depending on the model.

Cross vial with a sensitivity of 2-5 mm/m for an easy adjustment.

A quality wooden grip reduces thermal transfer during manual handling.



No	=			
		mm/m	For shafts \varnothing , mm	mm
05331000	Magnetic square level 0,02/150 x 150 x 40 mm	0,02	19 ÷ 108	150 x 150 x 40
05331002	Magnetic square level 0,05/150 x 150 x 40 mm	0,05	19 ÷ 108	150 x 150 x 40

TESA Precision Spirit Level with Micrometric Adjustment

Precision spirit level with micrometer adjustment.

For the measurement of inclinations from -20 to +4 mm/m.

1 division = 0,02 mm/m

Instrument features:

+ 1 micrometer rotation = + 2 mm/m (100 divisions)

+ 2 micrometer rotations = + 4 mm/m

- 10 micrometer rotations = - 20 mm/m

Prismatic measuring face (shafts \varnothing 19 to 120 mm).

Longitudinal vial with sensitivity of 0,02 mm/m

Cross vial with sensitivity of 2-5 mm/m for easy horizontal adjustment.

With side thermal insulators to reduce heat transfers to the instrument during manual handling.



No	=			
		mm/m	For shafts \varnothing , mm	mm
05331450	Precision spirit level with micrometer element 0,02 / 150 x 45 x 45 mm	0,02	19 ÷ 120	150 x 45 x 45

- DIN 877
- DIN 2276 Part 1
- Flat measuring faces with v-shaped grooves
- Hardened and ground steel
- Longitudinal and cross vials
- Wooden case
- Declaration of conformity



TESA Spirit Inclinometer with Protractor and Micrometer Element

Enables the measurement of angular deviations in any position of a cylindrical or flat surface.

Instrument features: prismatic measuring face (shafts \varnothing 17 to 80 mm) (DIN 877 + DIN 2276/1). Scale range: $2 \times 180^\circ$.

The adjustment is executed by disengaging the micrometer element by pressing in the direction indicated by the arrow. Afterwards the vial is oriented manually before engaging the micrometer element and executing the fine adjustment with the latter.

1 scale division = 1 degree.

1 division of the micrometer element = 1 Arcmin

Vial with sensitivity of 0,3 mm/m (= 1 Arcmin).

Error limit = 1,5 Arcmin



DIN 877



DIN 2276 part 1



Flat measuring faces with v-shaped groove



Hardened and ground steel base



Longitudinal and cross vials



Wooden case



Declaration of conformity



Scale division of micrometer element



Scale division of level



For shafts \varnothing , mm



mm



05331750

Spirit clinometer with angle protractor and micrometer element

1 Arcmin

1 Arcmin (0,30 mm/m)

$2 \times 180^\circ$

17 ÷ 80

150 x 35 x 116



Accessories for Clinometers and Levels



04768002	4 batteries LRC 6 AA, 1,5 V for CLINOBEVEL 1 USB, CLINOBEVEL 2, MICROBEVEL,
05360006	External switch with cable, L = 2 m, for CLINOBEVEL 1 USB
05360014	External switch, wireless, for CLINOBEVEL 1 USB
05360004	Connecting cable between 2 CLINOBEVEL 2, L = 2,5 m
04761059	4 batteries LR03 AAA, 1,5 V for NIVELTRONIC
03160007	Granite base 200 x 50 mm for horizontal NIVELTRONIC
03160008	Granite base 250 x 50 mm for horizontal NIVELTRONIC
03160009	Granite base 500 x 50 mm for horizontal NIVELTRONIC
03160048	Holder with voltage regulator (4,65 V) and 4x LR03 AAA for NIVELTRONIC



FLATNESS MEASUREMENT

ROCH Bevelled Straight Edges

Models with 1 bevelled edge, with insulating grip to limit the transfer of thermal heat during manual handling for optimal precision.



Bevelled edge

No	=	Flatness	
		μm	mm
0951750002	Bevelled straight edge	2	75
0951750003	Bevelled straight edge	2	100
0951750005	Bevelled straight edge	3	150
0951750006	Bevelled straight edge	3	200
0951750007	Bevelled straight edge	3	300



DIN 874 T2, NFE 11-104



Hardened steel to ≥ 650 HV 10



Straight edges up to 200 mm in a plastic case, ≥ 300 mm in a wooden case.



Declaration of conformity

SQUARES

ROCH Flat and Try Squares in Steel – Accuracy Class 1

Try square 90° flat in stainless steel, non-hardened



No	=	Flatness	A	Dimensions	
				Length of beams, mm	Section mm
0951751605	Try-square steel	15	With 90° hook	100 x 70	20 x 5
0951751607	Try-square steel	18	With 90° hook	150 x 100	28 x 6



Factory standard



Accuracy class 1



Accuracy class 1



Stainless steel, hardness 200 HRB,



Transport packing



Declaration of conformity





Factory standard



Hardened steel



Plastic case

Brown & Sharpe Try Square Set



06739001 Three square set B & S



Consisting of:

mm

µm

1 Try square

68 x 45

16

1 Try square

120 x 70

16

1 Try square

175 x 95

16



DIN 875 NFE 11-103



Accuracy class 00



Accuracy class 00



Accuracy class 00



Stainless steel,
hardened to
≥ 550 HV 30



Transport packing



Declaration of
conformity

ROCH Bevelled Edge Squares – Accuracy Class 00

Bevelled edge 90° squares in stainless steel, hardened



µm

Length of
beams, mm

Section of
beams
mm

0951751533 Bevelled edge square, stainless

3

50 x 40

14 x 4,5

0951751534 Bevelled edge square, stainless

3

75 x 50

16 x 4

0951751535 Bevelled edge square, stainless

3

100 x 70

20 x 5



ANGLE PROTRACTORS

Angle Protractor with Digital Display

Measuring ranges 1x 360°, 2x 180°, 4x 90°

Large decimal or sexagesimal display

2 measuring directions

Fine setting with adjustment screw

Locking system

Scale L = 200 mm (300 or 500 mm available as options)

RS232 data output

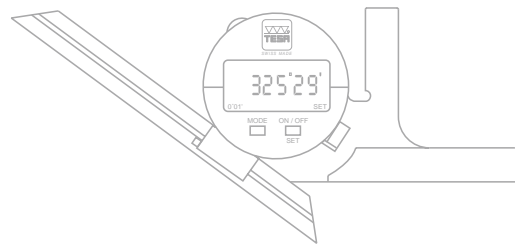

00630010 Angle protractor with digital display. Supplied with a scale of L = 200 mm

OPTIONAL ACCESSORIES:

00660004 Scale 200 mm

00660005 Scale 300 mm

00660006 Scale 500 mm

00660007 Supporting base with 1 flat measuring face and 1 prismatic measuring face

00660008 Square for measuring sharp angles

01961000 Lithium battery, 3V, CR 2032

04761062 Opto-USB cable, duplex, bidirectional communication



Measuring ranges:
1 x 360°, 2 x 180°,
4 x 90°



LCD, 5 digits + sign



0,01° / 1 minute
of arc



8,5 mm



Max. perm. error.: 4
minutes of arc



Stainless steel body,
hardened



Maximum rotation
speed.: 1080°/s



Preset to 0° or 180°



RS232 opto-coupled



1x CR2032 3,0 V



5000 hours



+5°C to +40°C



IP51 (CEI 529)



410 g



Wooden case (ISPM
15 andt NIPM 15)



Identification
number

Declaration of
conformity





2 circular scales



Main scale: 5'.
Double numbering in opposite directions.
Auxiliary scale: 10°



Max. perm. error: 5' (without accessory)



Hardened stainless steel



Plastic case



Declaration of conformity

EAC Angle Protractor with Dial

Circular scale with needle pointer
Easy reading on main and auxiliary scales
Very low hysteresis
Precision movement with compensation for mechanical play.



00610102

00610101

No	=		
00630001	EAC angle protractor with dial	4 x 90°	200
00630002	EAC angle protractor with dial	4 x 90°	300
OPTIONAL ACCESSORIES:			
00660002	Scale		200
00660003	Scale		300
00610102	Cast iron base with steel bottom surface, hardened		



5'



Max. perm. error: 5' (without accessory)



Stainless steel, hardened



Plastic case



Declaration of conformity

ETALON Angle Protractor with Vernier Scale



No	=			
076115566	ETALON angle protractor with vernier 200 mm	4 x 90°	No	200
076115567	ETALON angle protractor with vernier 300 mm	4 x 90°	No	300
OPTIONAL ACCESSORIES:				
00660002	Scale			200
00660003	Scale			300
00610102	Cast iron base with steel bottom surface, hardened			



Brown & Sharpe Angle Protractor - Multiple Combinations

This angle protractor combination set can be used as a scale, depth gauge, try square, centering tool, marker or even as a spirit level.

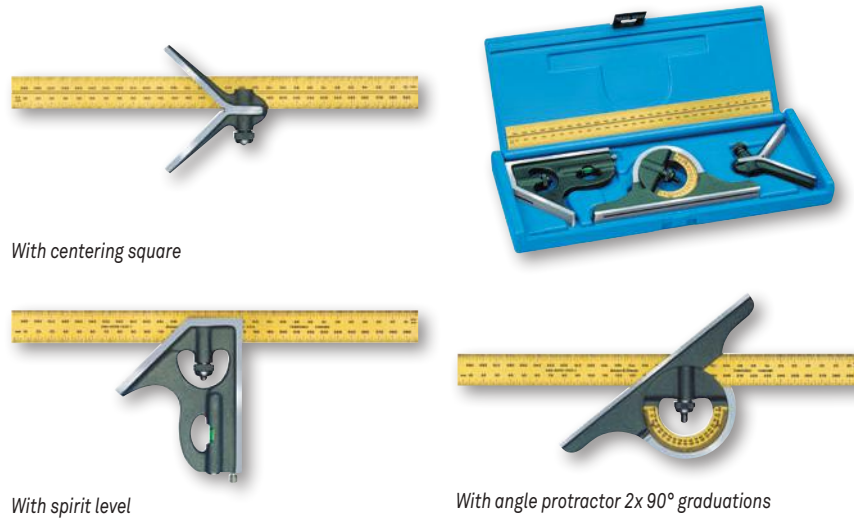

- Hardened steel. Measuring faces specially treated against scratches
- Pastic case

06719000	B&S angle protractor set with multiple combinations	Consisting of: - 1 Ruler graduated in millimetres, length 300 mm - 1 Angle protractor with 2 x 90° graduations - 1 Centering square - 1 Square head with scribe

Brown & Sharpe Sine Bar

Suited for setting ranges from 0 to 60°
 Sine function for establishing the angle that needs to be set on the basis of the length dimensions obtained from parallel gauge blocks.

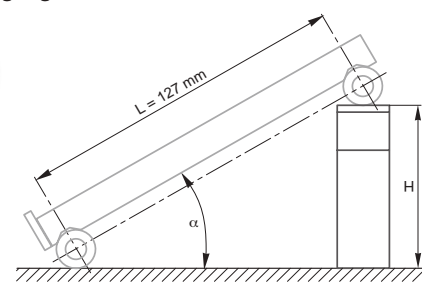

Example for the calculation of an angle
 Given: H = height of combination gauge blocks in mm
 L = length of B&S sine bar in mm
 Formula: $H = L \cdot \sin(\alpha)$
 $\sin(\alpha) = H/L$
 angle = arcsin (H/L)
 Calculation for determining angle knowing H et L values:
 angle = arcsin (89,803 / 127) = arcsin (0,70711) = 45°

- 5 µm
- Hardened alloy steel
- Removable front stop
- Cardboard box
- Declaration of conformity

06769005	B&S Sine bar	L (centre distance), mm 127 ± 0,004	mm 123 x 25



Length and Angle Standards

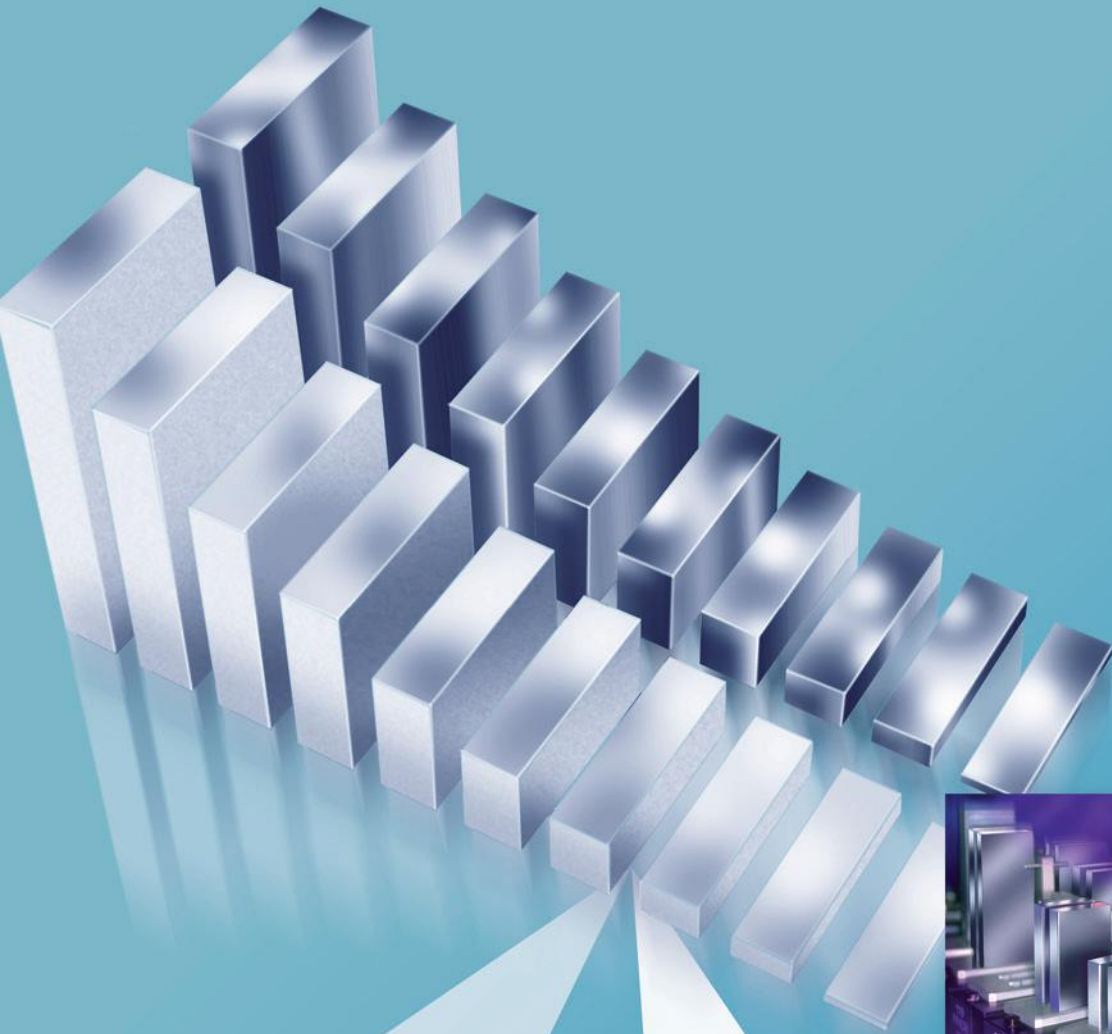

PURCHASING GAUGE BLOCKS CALLS FOR CONFIDENCE

The high accuracy of TESA's gauge blocks is the result of years of experience in producing and making use of these products.

- Use of high quality raw materials and appropriate heat treatment, thus guaranteeing a durable shape and dimensional stability of the gauge blocks over years.
- Very low deviations in flatness and parallelism of the measuring faces, resulting in highly accurate gauges.
- Unique flat lapping polish as well as edge rounding techniques, leading to superior wringability.
- Proper serial number marked on each gauge block.

ISO 3650

Gauge blocks with metric nominal lengths conform to ISO 3650:1998. This international standard is based on the ones published either in a region, e.g. the European standard EN ISO 3650:1998 or in a country, e.g. the Swiss standard SN EN ISO 3650, German standard DIN EN ISO 3650 or French standard NF EN ISO 3650. Gauge blocks with imperial nominal lengths comply with BS 4311 - Part 1. Compared to earlier standards, ISO 3650:1998 includes the following main changes :

- Withdrawal of the accuracy grade 00 (see "Which grade do you need").
- Introduction of requirements as regards the uncertainty of measurement in relation to the declaration of conformance of the product according to ISO 14253-1:1998.
- Review of some definitions and shortened form of terms according to normative references that are currently applicable (see drawing).

WHICH MATERIAL DO YOU NEED?

Steel

Steel gauge blocks have proven their reliability for more than a hundred years. This raw material remains the most commonly accepted for length standards.

- Steel gauge blocks provide high resistance to wear associated with a good property to adhere to other gauge blocks. However, steel must be protected against corrosion. Provided gauge blocks made from this material are properly handled, they will remain reliable for many years. TESA steel gauge blocks have the following key features:
- Highly alloyed steel
- Hardness guaranteed to 800 HV
- Artificially aged for optimum form and dimensional stability
- Coefficient of thermal expansion: $(11,5 \pm 1,0) \times 10^{-6} K^{-1}$

Tungsten Carbide

Gauge blocks in tungsten carbide are 10 times as resistant to wear as steel gauges. They are intended for frequent use, also where superior wringing quality is required. TESA tungsten carbide gauge blocks provide:

- Hardness guaranteed to 1400 HV
- Coefficient of thermal expansion: $(4,23 \pm 0,1) \times 10^{-6} K^{-1}$

Ceramic

Ceramic gauge blocks are extremely resistant to wear and scratches. Due to the properties of this material, any minor damage is unlikely to affect the wringability of their measuring faces. Being corrosion resistant, these gauge blocks are insensitive to "rusty hands", amongst other issues. Manufactured from stabilised zirconia, TESA ceramic gauge blocks have the following key features:

- Non-magnetizable
- Hardness guaranteed to 1400 HV
- Coefficient of thermal expansion: $(9,7 \pm 0,8) \times 10^{-6} K^{-1}$



WHICH GRADE DO YOU NEED?

Grade 2

These gauge blocks are commonly used as **Working Standards** in inspection rooms within a manufacturing area to set and calibrate measuring instruments and other equipment as well as to inspect tools, fixtures and machines.

Grade 1

Gauge blocks of this class are mainly used as **Working Standards** to set and calibrate plug gauges and measuring instruments in measuring rooms or inspection areas within a manufacturing area.

Tolerance Grade 0

These gauge blocks are designated for use as **Company Standards** in calibration laboratories or environmentally controlled inspection rooms to set and calibrate plug gauges as well as measuring equipment.

Calibration grade K

Gauge blocks of this tolerance class are intended for use as **Reference Standards** in metrology oriented laboratories of National Institutes, precision measuring rooms and other laboratories of National Calibration Services, whether officially accredited or not.

They should be used as masters to calibrate gauge blocks, length standards of same accuracy and also measuring instruments.

Precision Grade 00

The new standard ISO 3650 no longer takes this accuracy grade into consideration as the uncertainties of measurement achieved with the procedure applied for calibration usually lead to a disparity against specified tolerances.

The rules to the expression of uncertainty of measurement for proving the conformance or non conformance of the product with the specification, as stated in the standard ISO 14253- 1:1998, have dictated the decision to withdraw the accuracy grade 00.

A wide experience in practical use of gauge blocks has proven that gauges of the calibration class K could easily replace those of the earlier accuracy grade 00.

As a result, gauge blocks of grade 00 are no longer available.

CERTIFICATE OF CALIBRATION AND TRACEABILITY.

All set compositions from TESA are supplied with a certificate of calibration issued by the accredited calibration laboratory of a national calibration service.

This service can either be the Swiss calibration service (SCS), British calibration service (UKAS) or Deutsche Akkreditierungsstelle (DAkkS) depending on the manufacturer.

Accreditation is the authenticated assurance of the skills of the calibration laboratories as well as of the full traceability to national standards that conform with the International System of Units (SI).

This is for any reference standard or measuring equipment being used.

Owing to a multilateral agreement (MLA), any certificates of calibration issued by the members of the European Cooperation for Accreditation of Laboratories (EA) is internationally accepted.

DELIVERIES

TESA gauge blocks can be delivered individually or in full sets with nominal lengths as listed in this section. Additional gauge sets and lengths can be made available upon request. Since individual gauge blocks could no be listed in their whole here, any inquiry or purchase order should specify :

- Desired nominal length
- Chosen material
- Calibration grade or any other grade



Limit Deviations and Tolerances

	Limit deviations t_e			
	Tolerances t_v			
	Flatness tolerances t_f			
Nominal length	Calibration grades and other grades			
	K	0	1	2
	Flatness tolerance t_f			
mm	μm	μm	μm	μm
$0,5 = l_n \leq 150$	0,05	0,1	0,15	0,25
$150 < l_n \leq 500$	0,1	0,15	0,18	0,25
$500 < l_n \leq 1000$	0,15	0,18	0,2	0,25

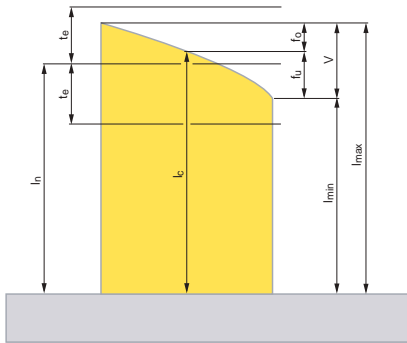

Nominal length l_n ; Central length l_c ; Variation v with f_0 and f_1 ; Limit deviations t_e at any point proceeding from the nominal length.

Nominal length	Calibration grade K		Grade 0		Grade 1		Grade 2	
	Limit deviation of length at any point from nominal length	Tolerance for the variation in length	Limit deviation of length at any point from nominal length	Tolerance for the variation in length	Limit deviation of length at any point from nominal length	Tolerance for the variation in length	Limit deviation of length at any point from nominal length	Tolerance for the variation in length
LIMIT DEVIATIONS AND TOLERANCES ACCORDING TO ISO 3650								
mm	$\pm t_e$ μm	t_v μm	$\pm t_e$ μm	t_v μm	$\pm t_e$ μm	t_v μm	$\pm t_e$ μm	t_v μm
$0,5 = l_n \leq 10$	0,2	0,05	0,12	0,1	0,2	0,16	0,45	0,3
$10 < l_n \leq 25$	0,3	0,05	0,14	0,1	0,3	0,16	0,6	0,3
$25 < l_n \leq 50$	0,4	0,06	0,2	0,1	0,4	0,18	0,8	0,3
$50 < l_n \leq 75$	0,5	0,06	0,25	0,12	0,5	0,18	1,0	0,35
$75 < l_n \leq 100$	0,6	0,07	0,3	0,12	0,6	0,2	1,2	0,35
$100 < l_n \leq 150$	0,8	0,08	0,4	0,14	0,8	0,2	1,6	0,4
$150 < l_n \leq 200$	1,0	0,09	0,5	0,16	1,0	0,25	2,0	0,4
$200 < l_n \leq 250$	1,2	0,1	0,6	0,16	1,2	0,25	2,4	0,45
$250 < l_n \leq 300$	1,4	0,1	0,7	0,18	1,4	0,25	2,8	0,5
$300 < l_n \leq 400$	1,8	0,12	0,9	0,2	1,8	0,3	3,6	0,5
$400 < l_n \leq 500$	2,2	0,14	1,1	0,25	2,2	0,35	4,4	0,6
$500 < l_n \leq 600$	2,6	0,16	1,3	0,25	2,6	0,40	5,0	0,7
$600 < l_n \leq 700$	3,0	0,18	1,5	0,3	3,0	0,45	6,0	0,7
$700 < l_n \leq 850$	3,4	0,2	1,7	0,3	3,4	0,5	6,5	0,8
$800 < l_n \leq 900$	3,8	0,2	1,9	0,35	3,8	0,5	7,5	0,9
$900 < l_n \leq 1000$	4,2	0,25	2,0	0,4	4,2	0,6	8,0	1,0
LIMIT DEVIATIONS AND TOLERANCES ACCORDING TO BS 4311, PART 1:1993								
in	$\pm t_e$ μin	t_v μin	$\pm t_e$ μin	t_v μin	$\pm t_e$ μin	t_v μin	$\pm t_e$ μin	t_v μin
$l_n \leq 0,4$	5	2	5	4	10	6	20	12
$0,4 < l_n \leq 1$	6	2	6	4	12	6	25	12
$1 < l_n \leq 1$	8	3	8	4	15	7	30	12
$2 < l_n \leq 3$	10	3	10	5	20	7	40	14
$3 < l_n \leq 4$	12	3	12	5	25	8	50	14
LIMIT DEVIATIONS AND TOLERANCES ACCORDING TO FACTORY STANDARD FOR GAUGE BLOCKS OVER 4 IN								
in	$\pm t_e$ μin	t_v μin	$\pm t_e$ μin	t_v μin	$\pm t_e$ μin	t_v μin	$\pm t_e$ μin	t_v μin
$4 < l_n \leq 6$	31	3	15	5	31	8	63	16
$6 < l_n \leq 8$	40	3	20	6	40	10	79	16
$8 < l_n \leq 10$	47	4	23	6	47	10	95	18
$10 < l_n \leq 12$	55	4	28	7	55	10	110	20
$12 < l_n \leq 16$	70	5	35	8	70	12	140	20
$16 < l_n \leq 20$	87	5	43	10	87	14	174	24



GAUGE BLOCKS

Gauge Block Set M32, M47, M88, M112 and M122.

Nominal lengths 1 ÷ 100 mm in steel, carbide or ceramic.

Grades K, 0, 1 and 2 available in all sets. Steel gauges to all grades with DAkkS certificate. Carbide or ceramic gauges to all grades with UKAS certificate.



ISO 3650

Limit deviations t_x , see Table

Tolerances t_x , see Table

see Table

Steel: highly alloyed, wear resistant.
Tungsten carbide: wear resistant and stable.
Ceramic: stabilised zirconia, extremely resistant to wear and scratches

Steel: $(11,5 \pm 1,0) \times 10^{-6} K^{-1}$
Tungsten carbide: $(4,23 \pm 0,1) \times 10^{-6} K^{-1}$
Ceramic: $(9,7 \pm 0,8) \times 10^{-6} K^{-1}$

Supplied individually or in sets

Wooden case

Identification number

Steel gauges to all grades with DAkkS certificate. Carbide or ceramic gauges to all grades with UKAS certificate

TESA Gauge Block Set M32, Metric

No		Grade
0651516027	Steel	K
0651515027	Steel	0
0651511027	Steel	1
0651512028	Steel	2

Set compositions

mm	Steps, mm	Pieces
1,005	–	1
1,01 ÷ 1,09	0,01	9
1,1 ÷ 1,9	0,1	9
1,0 ÷ 9,0	1,0	9
10, 20, 30, 60	–	4

TESA Gauge Block Set M47, Metric

No		Grade
0651516021	Steel	K
0651515021	Steel	0
0651511021	Steel	1
0651512021	Steel	2

Set compositions

mm	Steps, mm	Pieces
1,005	–	1
1,01 ÷ 1,09	0,01	9
1,1 ÷ 1,9	0,1	9
1,0 ÷ 24,0	1,0	24
25 ÷ 100	25	4

TESA Gauge Block Set M88, Metric

No		Grade
0651516014	Steel	K
0651515014	Steel	0
0651511014	Steel	1
0651512014	Steel	2

Set compositions

mm	Steps, mm	Pieces
1,0005	–	1
1,001 ÷ 1,009	0,001	9
1,01 ÷ 1,49	0,01	49
0,5 ÷ 9,5	0,5	19
10 ÷ 100	10	10

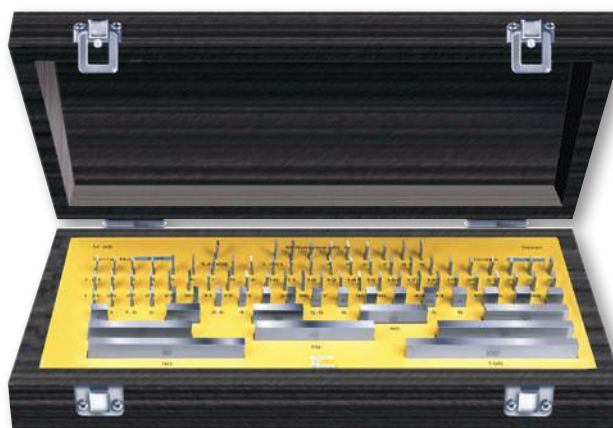

TESA Gauge Block Set M112, Metric

No			Grade
0651516012	Steel	K	K
0651515012	Steel	0	0
0651511012	Steel	1	1
0651512012	Steel	2	2

Set compositions

mm	Steps, mm	Pieces
1,0005	–	1
1,001 ÷ 1,009	0,001	9
1,01 ÷ 1,49	0,01	49
0,5 ÷ 24,5	0,5	49
25 ÷ 100	25	4

TESA Gauge Block Set M122, Metric

No			Grade
0651516011	Steel	K	K
0651515011	Steel	0	0
0651511011	Steel	1	1
0651512011	Steel	2	2

Set compositions

mm	Steps, mm	Pieces
1,0005	–	1
1,001 ÷ 1,009	0,001	9
1,01 ÷ 1,49	0,01	49
1,6 ÷ 1,9	0,1	4
0,5 ÷ 24,5	0,5	49
30 ÷ 100	10	8
25,75	–	2



Special Versions

Available on request :

- Tungsten carbide gauge block set
- Ceramic gauge block set
- TESA maintenance kit



ISO 3650

Limit deviations t_s , see Table

Tolerances t_s , see Table

see Table

Steel: highly alloyed, wear resistant.
Tungsten carbide: wear resistant and stable.
Ceramic: stabilised zirconia, extremely resistant to wear and scratches

Steel: $(11,5 \pm 1,0) \times 10^{-6} K^{-1}$
Tungsten carbide: $(4,23 \pm 0,1) \times 10^{-6} K^{-1}$
Ceramic: $(9,7 \pm 0,8) \times 10^{-6} K^{-1}$

Supplied individually or in sets

Wooden case

Identification number

Steel gauges to all grades with DAkkS certificate.
Carbide or ceramic gauges to all grades with UKAS certificate





Diameter and thickness as shown in table



Optical flats with 2 flat measuring faces. No guaranty can be given for parallelism.



Wooden case



Declaration of conformity

ACCESSORIES FOR GAUGE BLOCKS

The interference lenses allow visual inspection of the surface of the gauge blocks.

TESA Optical Flats

Used for examining flatness and adhesion of gauge blocks or any other test pieces having flat faces with same high grade of accuracy.

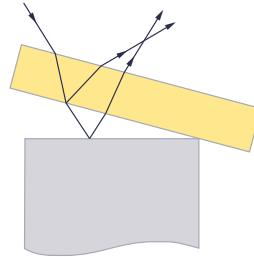

02530050

50

15

0,125

02530075

75

20

0,125

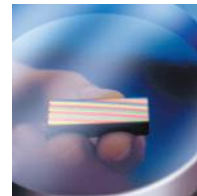

Light source: 35 W sodium lamp, 89% monochromatic, colour yellow, wavelength 0,575 µm



Surface plate: 0,5 µm



Surface plate: 2,5 µm



406 x 406 x 355 mm (W x D x H)



Surface plate in hardened steel



Case in lacquered wood



See table



Suited carrying case

TESA Monochromatic Light Unit

For use with optical flats or optical parallels to measure both the flatness and parallelism of the measuring faces by interferometry.

Monochromatic light source providing high-contrast interference fringes.

This light unit uses a single wavelength so that bright/light fringes only are visible.

The light source at the rear of the case also permits a visual examination, e.g. with the aid of a knife-edge or bevelled straight edge.

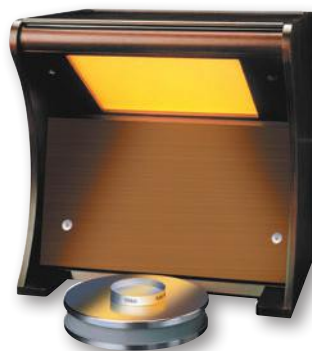

0652500422

Universal monochromatic light

V

210 ÷ 230

STANDARD ACCESSORIES:

0651570269

200 mm dia. surface plate, lapped and polished measuring face

0652500424

Sodium light bulb (spare lamp)



Brown & Sharpe Angle Gauges

For setting and calibration purposes – Smallest step to 15' (1/4°).



Width:
6,35 mm (1/4 in)
Length:
≥ 76,2 mm (3 in)



06769002 Precision angle block set

Set Composition
15' / 30' / 1° / 2° / 3° / 4° / 5° /
10° / 15° / 20° / 25° / 30°

Steel Balls – Brown & Sharpe Steel Balls

Steel balls are used to measure internal tapers and similar.



06769009 Steel ball set

mm

Step, mm

Pieces by Nominal Ø /total pieces

1 ÷ 25

1

2 / 50



PLUG AND RING GAUGES

The high-precision plug gauges (rods CARY) are specially adapted to inspect small diameters from 0,05 mm to 10 mm.

The ring gauges allow to inspect cylindrical parts such as pivots and spline shafts, diameters from 0,06 mm to 30 mm.

TESA CARY Plug Gauges, Diameters 0,050 to 0,300 mm – Type TDH

Due to their small size, these plug gauges are best handled using tweezers.

- EN ISO 1938
- Steel
- Accuracy: STANDARD (blue handle) $\pm 0,4 \mu\text{m}$. ETALON (yellow handle) $\pm 0,15 \mu\text{m}$
- Light alloy, coloured handle with engraved nominal diameter
- Inspection report available on request



No			
	μm	mm	Step, μm
CJ1D1S2	$\pm 0,4 \mu\text{m}$	$0,050 \div 0,080$	2
CJ1D2S2	$\pm 0,4 \mu\text{m}$	$0,081 \div 0,309$	2
CJ1D1S0	$\pm 0,4 \mu\text{m}$	$0,050 \div 0,080$	1
CJ1D2S0	$\pm 0,4 \mu\text{m}$	$0,081 \div 0,309$	1
CJ1D1E2	$\pm 0,15 \mu\text{m}$	$0,050 \div 0,080$	2
CJ1D2E2	$\pm 0,15 \mu\text{m}$	$0,081 \div 0,309$	2
CJ1D1E0	$\pm 0,15 \mu\text{m}$	$0,050 \div 0,080$	1
CJ1D2E0	$\pm 0,15 \mu\text{m}$	$0,081 \div 0,309$	1

OPTIONAL ACCESSORIES:

- CJ1ED25N Wooden case for 25 TDH plug gauges
- CJ1XDL Plastic packaging for TDH/TLH/TXH plug gauges

TDH gauge sizes

A mm	B1 mm	B2 mm	B3 mm	C mm	
$0,050 \div 0,100$	10,3	31,8	33,6	0,8	
$0,100 \div 0,150$	10,5	32	34	1,0	
$0,150 \div 0,200$	10,7	32,2	34,2	1,2	
$0,200 \div 0,250$	10,9	32,4	34,4	1,4	
$0,250 \div 0,300$	11,1	32,6	34,6	1,6	

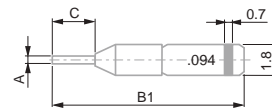

TESA CARY Plug Gauges, Diameters 0,050 to 0,300 mm – Type TLH

This type is identical to the TDH one, but with a 30 mm long handle.

- EN ISO 1938
- Steel
- Accuracy: STANDARD (blue handle) $\pm 0,4 \mu\text{m}$. ETALON (yellow handle) $\pm 0,15 \mu\text{m}$
- Light alloy, coloured handle with engraved nominal diameter
- Inspection report available on request



No			
	μm	mm	Step, μm
CJ1L1S2	$\pm 0,4 \mu\text{m}$	$0,050 \div 0,080$	2
CJ1L2S2	$\pm 0,4 \mu\text{m}$	$0,081 \div 0,309$	2
CJ1L1S0	$\pm 0,4 \mu\text{m}$	$0,050 \div 0,080$	1
CJ1L2S0	$\pm 0,4 \mu\text{m}$	$0,081 \div 0,309$	1
CJ1L1E2	$\pm 0,15 \mu\text{m}$	$0,050 \div 0,080$	2
CJ1L2E2	$\pm 0,15 \mu\text{m}$	$0,081 \div 0,309$	2
CJ1L1E0	$\pm 0,15 \mu\text{m}$	$0,050 \div 0,080$	1
CJ1L2E0	$\pm 0,15 \mu\text{m}$	$0,081 \div 0,309$	1

OPTIONAL ACCESSORIES:

- CJ1EL25N Wooden case for 25 TLH plug gauges
- CJ1XDL Plastic packaging for TDH/TLH/TXH plug gauges

TLH gauge sizes

A mm	B1 mm	B2 mm	B3 mm	C mm	
$0,050 \div 0,100$	10,3	31,8	33,6	0,8	
$0,100 \div 0,150$	10,5	32	34	1,0	
$0,150 \div 0,200$	10,7	32,2	34,2	1,2	
$0,200 \div 0,250$	10,9	32,4	34,4	1,4	
$0,250 \div 0,300$	11,1	32,6	34,6	1,6	



TESA CARY Plug Gauges, Diameters 0,100 to 0,300 mm – Type TLH-5 – Type TLH-10

Length of 5 or 10 mm.



No			
	μm	mm	Step, μm
CJ1L5S2	± 0,5 μm	0,101 ÷ 0,309	2
CJ1L10S2	± 0,8 μm	0,101 ÷ 0,309	2
CJ1L5S0	± 0,5 μm	0,101 ÷ 0,309	1
CJ1L10S0	± 0,8 μm	0,101 ÷ 0,309	1
CJ1L5E2	± 0,2 μm	0,101 ÷ 0,309	2
CJ1L10E2	± 0,3 μm	0,101 ÷ 0,309	2
CJ1L5E0	± 0,2 μm	0,101 ÷ 0,309	1
CJ1L10E0	± 0,3 μm	0,101 ÷ 0,309	1

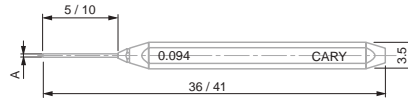

Accuracy:
STANDARD
(blue handle)
TLH-5 ± 0,5 μm,
TLH-10 ± 0,8 μm;
ETALON (yellow
handle)
TLH-5 ± 0,2 μm,
TLH-10 ± 0,3 μm



Light alloy,
coloured
handle
with engraved
nominal
diameter



Inspection
report available
on request

TESA CARY Plug Gauges, Diameters 0,050 to 0,300 mm – Type TTLH

Double-ended plug gauges consisting of two TDH-type plug gauges.



No			
	μm	mm	Step, μm
CJ1LL1S0	± 0,4 μm	0,050 ÷ 0,080	1
CJ1LL2S0	± 0,4 μm	0,081 ÷ 0,309	1
CJ1LL1E0	± 0,15 μm	0,050 ÷ 0,080	1
CJ1LL2E0	± 0,15 μm	0,081 ÷ 0,309	1

TTLH gauge sizes

A mm	B1 mm	B2 mm	B3 mm	C mm		
0,050 ÷ 0,100	10,3	31,8	33,6	0,8		
0,100 ÷ 0,150	10,5	32	34	1,0		
0,150 ÷ 0,200	10,7	32,2	34,2	1,2		
0,200 ÷ 0,250	10,9	32,4	34,4	1,4		
0,250 ÷ 0,300	11,1	32,6	34,6	1,6		

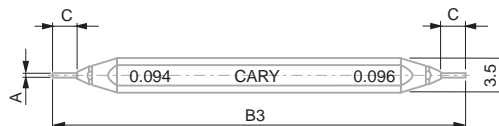

Accuracy:
STANDARD
(blue handle)
± 0,4 μm.
ETALON (yellow
handle) ± 0,15 μm



Light alloy,
coloured
handle
with engraved
nominal
diameter



Inspection
report available
on request





EN ISO 1938

Steel

Accuracy: STANDARD (blue handle) $\pm 0,4 \mu\text{m}$ for diameters $0,3 \div 3 \text{ mm}$ or $\pm 0,5 \mu\text{m}$ for diameters $3 \div 10 \text{ mm}$. ETALON (yellow handle) $\pm 0,25 \mu\text{m}$ for diameters $0,3 \div 3 \text{ mm}$ or $\pm 0,3 \mu\text{m}$ for diameters $3 \div 10 \text{ mm}$.

Light alloy, coloured handle with engraved nominal diameter

Inspection report available on request

TESA CARY Steel Plug Gauges, Diameters 0,3 to 10 mm – Type TXH

Single-ended steel plug gauges (1 item).



No	μm	mm	Step, μm
CJ1X1S10	$\pm 0,4$	$0,300 \div 1,509$	10
CJ1X2S10	$\pm 0,4$	$1,510 \div 3,509$	10
CJ1X3S10	$\pm 0,5$	$3,510 \div 10,000$	10
CJ1X1S2	$\pm 0,4$	$0,300 \div 1,509$	2
CJ1X2S2	$\pm 0,4$	$1,510 \div 3,509$	2
CJ1X1S0	$\pm 0,4$	$0,300 \div 1,509$	1
CJ1X2S0	$\pm 0,4$	$1,510 \div 3,509$	1
CJ1X3S0	$\pm 0,5$	$3,510 \div 10,000$	1
CJ1X1E10	$\pm 0,25$	$0,300 \div 1,509$	10
CJ1X2E10	$\pm 0,25$	$1,510 \div 3,509$	10
CJ1X3E10	$\pm 0,3$	$3,510 \div 10,000$	10
CJ1X1E2	$\pm 0,25$	$0,300 \div 1,509$	2
CJ1X2E2	$\pm 0,25$	$1,510 \div 3,509$	2
CJ1X1E0	$\pm 0,25$	$0,300 \div 1,509$	1
CJ1X2E0	$\pm 0,25$	$1,510 \div 3,509$	1
CJ1X3E0	$\pm 0,3$	$3,510 \div 10,000$	1

OPTIONAL ACCESSORIES:

CJ1PTXK	Box for 50 plug gauges from $\varnothing 0,300 \div 1,509 \text{ mm}$
CJ1MTXK	Box for 50 plug gauges from $\varnothing 0,510 \div 3,509 \text{ mm}$
CJ1GTXK	Box for 50 plug gauges from $\varnothing 3,510 \div 10,00 \text{ mm}$

Gauge sizes TXH

\varnothing	A mm	B1 mm	B2 mm	C mm	D mm
$0,30 \div 0,50$		38	41	3	3,5
$0,50 \div 1,00$		39	43	4	3,5
$1,00 \div 1,50$		40	45	5	3,5
$1,50 \div 2,00$		46	52	6	5
$2,00 \div 2,50$		47	54	7	5
$2,50 \div 3,00$		48	56	8	5
$3,00 \div 3,50$		49	58	9	5
$3,50 \div 4,00$		60	70	10	8
$4,00 \div 5,00$		61	72	11	8
$5,00 \div 10,00$		62	74	12	8

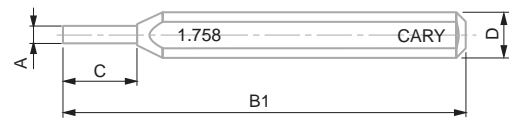

TESA CARY Steel Plug Gauges, Diameters 0,3 to 10 mm – Type TTXH

Steel plug gauges, type GO/NO GO (2 items).

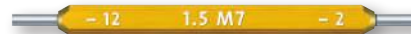
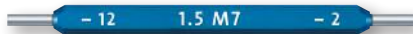

No	μm	mm	Step, μm
CJ1XX1S0	$\pm 0,4$	$0,300 \div 1,509$	1
CJ1XX2S0	$\pm 0,4$	$1,510 \div 3,509$	1
CJ1XX3S0	$\pm 0,5$	$3,510 \div 6,509$	1
CJ1XX4S0	$\pm 0,5$	$6,510 \div 10,000$	1
CJ1XX1E0	$\pm 0,25$	$0,300 \div 1,509$	1
CJ1XX2E0	$\pm 0,25$	$1,510 \div 3,509$	1
CJ1XX3E0	$\pm 0,3$	$3,510 \div 6,509$	1
CJ1XX4E0	$\pm 0,3$	$6,510 \div 10,000$	1

OPTIONAL ACCESSORIES:

CJ1PTXK	Box for 50 plug gauges from $\varnothing 0,300 \div 1,509 \text{ mm}$
CJ1MTXK	Box for 50 plug gauges from $\varnothing 0,510 \div 3,509 \text{ mm}$
CJ1GTXK	Box for 50 plug gauges from $\varnothing 3,510 \div 10,00 \text{ mm}$

TTXH gauge sizes

\varnothing	A mm	B1 mm	B2 mm	C mm	D mm
$0,30 \div 0,50$		38	41	3	3,5
$0,50 \div 1,00$		39	43	4	3,5
$1,00 \div 1,50$		40	45	5	3,5
$1,50 \div 2,00$		46	52	6	5
$2,00 \div 2,50$		47	54	7	5
$2,50 \div 3,00$		48	56	8	5
$3,00 \div 3,50$		49	58	9	5
$3,50 \div 4,00$		60	70	10	8
$4,00 \div 5,00$		61	72	11	8
$5,00 \div 10,00$		62	74	12	8

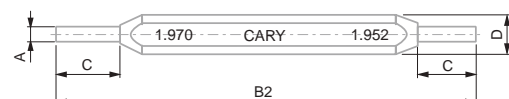

EN ISO 1938

Steel

Accuracy: STANDARD (blue handle) $\pm 0,4 \mu\text{m}$ for diameters $0,3 \div 3 \text{ mm}$ or $\pm 0,5 \mu\text{m}$ for diameters $3 \div 10 \text{ mm}$. ETALON (yellow handle) $\pm 0,25 \mu\text{m}$ for diameters $0,3 \div 3 \text{ mm}$ or $\pm 0,3 \mu\text{m}$ for diameters $3 \div 10 \text{ mm}$.

Light alloy, coloured handle with engraved nominal diameter

Inspection report available on request



TESA CARY Tungsten Carbide Plug Gauges, Diameters 0,3 to 6 mm – Type TCH

Single-ended tungsten carbide plug gauges (1 item).



No				
	µm	mm	Step, µm	
CJ1C1S10	± 0,4	0,300 ÷ 1,509	10	
CJ1C2S10	± 0,4	1,510 ÷ 3,509	10	
CJ1C3S10	± 0,5	3,510 ÷ 6,000	10	
CJ1C1S0	± 0,4	0,300 ÷ 1,509	1	
CJ1C2S0	± 0,4	1,510 ÷ 3,509	1	
CJ1C3S0	± 0,5	3,510 ÷ 6,000	1	
CJ1C1E10	± 0,25	0,300 ÷ 1,509	10	
CJ1C2E10	± 0,25	1,510 ÷ 3,509	10	
CJ1C3E10	± 0,3	3,510 ÷ 6,000	10	
CJ1C1E0	± 0,25	0,300 ÷ 1,509	1	
CJ1C2E0	± 0,25	1,510 ÷ 3,509	1	
CJ1C3E0	± 0,3	3,510 ÷ 6,000	1	

OPTIONAL ACCESSORIES:

- CJ1PTXK Box for 50 plug gauges from Ø 0,300 ÷ 1,509 mm
- CJ1MTXK Box for 50 plug gauges from Ø 0,510 ÷ 3,509 mm
- CJ1GTXK Box for 50 plug gauges from Ø 3,510 ÷ 10,00 mm

TCH Plug gauge sizes

		A mm	B1 mm	B2 mm	C mm	D mm
0,30 ÷ 0,50		38	41	3	3,5	
0,50 ÷ 1,00		39	43	4	3,5	
1,00 ÷ 1,50		40	45	5	3,5	
1,50 ÷ 2,00		46	52	6	5	
2,00 ÷ 2,50		47	54	7	5	
2,50 ÷ 3,00		48	56	8	5	
3,00 ÷ 3,50		49	58	9	5	
3,50 ÷ 4,00		60	70	10	8	
4,00 ÷ 5,00		61	72	11	8	
5,00 ÷ 10,00		62	74	12	8	

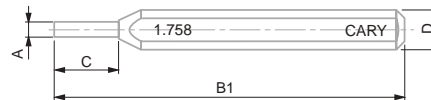

TESA CARY Tungsten Carbide Plug Gauges, Diameters 0,3 to 6 mm – Type TTCH

Tungsten carbide plug gauges, type GO/NO GO (2 items).

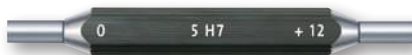

No				
	µm	mm	Step, µm	
CJ1CC1S0	± 0,4	0,300 ÷ 1,509	1	
CJ1CC2S0	± 0,4	1,510 ÷ 3,509	1	
CJ1CC3S0	± 0,5	3,510 ÷ 6,000	1	
CJ1CC1E0	± 0,25	0,300 ÷ 1,509	1	
CJ1CC2E0	± 0,25	1,510 ÷ 3,509	1	
CJ1CC3E0	± 0,3	3,510 ÷ 6,000	1	

CONSISTING OF:

- CJ1PTXK Box for 50 plug gauges from Ø 0,300 ÷ 1,509 mm
- CJ1MTXK Box for 50 plug gauges from Ø 0,510 ÷ 3,509 mm
- CJ1GTXK Box for 50 plug gauges from Ø 3,510 ÷ 10,00 mm

Plug gauge sizes TTCH

		A mm	B1 mm	B2 mm	C mm	D mm
0,30 ÷ 0,50		38	41	3	3,5	
0,50 ÷ 1,00		39	43	4	3,5	
1,00 ÷ 1,50		40	45	5	3,5	
1,50 ÷ 2,00		46	52	6	5	
2,00 ÷ 2,50		47	54	7	5	
2,50 ÷ 3,00		48	56	8	5	
3,00 ÷ 3,50		49	58	9	5	
3,50 ÷ 4,00		60	70	10	8	
4,00 ÷ 5,00		61	72	11	8	
5,00 ÷ 10,00		62	74	12	8	

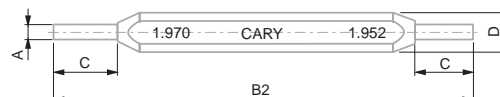

- EN ISO 1938
- Tungsten carbide
- Accuracy: STANDARD (black handle) ± 0,4 µm for diameters 0,3 ÷ 3 mm or ± 0,5 µm for diameters 3 ÷ 6 mm. ETALON (red handle) ± 0,25 µm for diameters 0,3 ÷ 3 mm or ± 0,3 µm for diameters 3 ÷ 6 mm.
- Light alloy, coloured handle with engraved nominal value
- Inspection report available on request

- EN ISO 1938
- Tungsten carbide
- Accuracy: STANDARD (black handle) ± 0,4 µm for diameters 0,3 ÷ 3 mm or ± 0,5 µm for diameters 3 ÷ 6 mm. ETALON (red handle) ± 0,25 µm for diameters 0,3 ÷ 3 mm or ± 0,3 µm for diameters 3 ÷ 6 mm.
- Light alloy, coloured handle with engraved nominal value
- Inspection report available on request

TESA CARY Measuring Pins in Steel, Ø 0,10 to 10 mm, Type PNH with Handle, for Thread Measurement



- EN ISO 1938
- Hardened steel, ground and lapped
- Accuracy: STANDARD (blue handle) $\pm 0,8 \mu\text{m}$ for diameters 0,1 ÷ 10 mm. ETALON (yellow handle) $\pm 0,3 \mu\text{m}$ for diameters 0,1 ÷ 6 mm or $\pm 0,5 \mu\text{m}$ for diameters 6 ÷ 10 mm
- Aluminium, coloured handle with engraved nominal diameter
- Inspection report available on request

No	μm	mm	Step, μm
CJ1N1S	$\pm 0,8$	0,10 ÷ 0,15	10
CJ1N2S	$\pm 0,8$	0,16 ÷ 0,50	10
CJ1N3S	$\pm 0,8$	0,51 ÷ 4,00	10
CJ1N4S	$\pm 0,8$	4,01 ÷ 10,00	10
CJ1N1E	$\pm 0,3$	0,10 ÷ 0,15	10
CJ1N2E	$\pm 0,3$	0,16 ÷ 0,50	10
CJ1N3E	$\pm 0,3$	0,51 ÷ 4,00	10
CJ1N4E	$\pm 0,5$	4,01 ÷ 10,00	10

Plug gauge sizes PNH

A mm	B mm	C mm	D mm	E mm
0,10 ÷ 0,15	20	9,5	1,8	0,9
0,16 ÷ 0,30	32	9,5	1,8	0,9
0,31 ÷ 1,10	32	14	3,5	1,5
1,11 ÷ 10,00	32	14	5	2

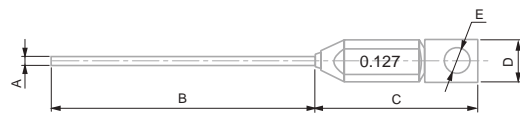

OPTIONAL ACCESSORIES:

- CJ1N50 Suited clear box for 50 PNH thread wires
- CJ1N3 Carrying tube for 3 PNH thread wires
- CJ1NGC Box engraving for each diameter
- CJ1NLSM Thread wire alone, without handle

Accessories for Plug Gauges and Setting Rings



No	
CJ1ED25N	Wooden case for 25 TDH plug gauges
CJ1EL25N	Wooden case for 25 TLH plug gauges
CJ1XDL	Plastic packaging for TDH/TLH/TXH plug gauges
CJ1PTXK	Box for 50 plug gauges from Ø 0,300 ÷ 1.509 mm
CJ1MTXK	Box for 50 plug gauges from Ø 0,510 ÷ 3.509 mm
CJ1GTXK	Box for 50 plug gauges from Ø 3,510 ÷ 10,00 mm
CJ1N50	Suited clear box for 50 PNH thread wires
CJ1N3	Carrying tube for 3 PNH thread wires
CJ1NGC	Box engraving for each diameter
CJ1NLSM	Thread wire alone, without handle



TESA CARY Carbide Ring Gauges, Diameters 0,060 to 5 mm, Type BCH

Type BCH 1 Carbide ring gauge Type BIMHm

2 BCH carbide ring gauges mounted in pairs on plates for use as GO/NO GO type gauges.

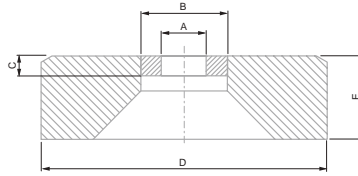

No	=	∅	A
		mm	Step, µm
CJ1B1C	BCH	0,060 ÷ 0,150	1
CJ1B2C	BCH	0,151 ÷ 1,500	1
CJ1B3C	BCH	1,501 ÷ 2,500	1
CJ1B4C	BCH	2,501 ÷ 4,000	1
CJ1B5C	BCH	4,001 ÷ 4,999	1
CJ1B1IM	BIMHm	0,060 ÷ 0,150	1
CJ1B2IM	BIMHm	0,151 ÷ 1,500	1
CJ1B3IM	BIMHm	1,501 ÷ 2,500	1
CJ1B4IM	BIMHm	2,501 ÷ 4,000	1
CJ1B5IM	BIMHm	4,001 ÷ 4,999	1

Ring gauges sizes BCH

∅	Ring gauges			Outer rings	
	A mm	B mm	C mm	D mm	E mm
0,060 ÷ 0,50	1,8	0,5	8	2,5	
0,50 ÷ 0,75	1,8	0,5	8	2,5	
0,75 ÷ 1,25	2,4	0,75	8	2,5	
1,25 ÷ 1,50	3	0,9	8	2,5	
1,50 ÷ 2,50	5	1,5	12	4	
2,50 ÷ 4,00	8	2,4	16	5,5	
4,00 ÷ 5,00	10	3	20	7	



EN ISO 1938
Factory standard



∅ 0,015 ÷ 3 mm:
± 0,6 µm
∅ 3 ÷ 4,999 mm:
± 0,75 µm



Tungsten carbide



Inserted into a blue coloured, light alloy ring for easier handling. Also with engraved nominal diameter of the ring



Inspection report from 2 mm available on request

TESA CARY Steel Ring Gauges, Diameters 0,151 to 5 mm, Type BAH

Designed for inspecting cylindrical components such as pivots or axles.

Used to determine external diameters.

Type BAH 1 steel ring gauge.

Type BIMHa 2 BAH steel ring gauges mounted in pairs on plates for use as GO/NO GO type gauges

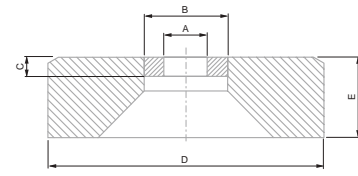

No	=	∅	A
		mm	Step, µm
CJ1B2A	BAH	0,151 ÷ 1,500	1
CJ1B3A	BAH	1,501 ÷ 2,500	1
CJ1B4A	BAH	2,501 ÷ 4,000	1
CJ1B5A	BAH	4,001 ÷ 4,999	1
CJ1B2IA	BIMHa	0,151 ÷ 1,500	1
CJ1B3IA	BIMHa	1,501 ÷ 2,500	1
CJ1B4IA	BIMHa	2,501 ÷ 4,000	1
CJ1B5IA	BIMHa	4,001 ÷ 4,999	1

Ring gauge sizes BAH

∅	Ring gauges			Outer rings	
	A mm	B mm	C mm	D mm	E mm
0,060 ÷ 0,50	1,4	0,35	8	2,5	
0,50 ÷ 0,75	1,8	0,5	8	2,5	
0,75 ÷ 1,25	2,4	0,75	8	2,5	
1,25 ÷ 1,50	3	0,9	8	2,5	
1,50 ÷ 2,50	5	1,5	12	4	
2,50 ÷ 4,00	8	2,4	16	5,5	
4,00 ÷ 5,00	10	3	20	7	



EN ISO 1938
Factory standard



∅ 0,15 ÷ 3 mm:
± 0,6 µm
∅ 3 ÷ 4,999 mm:
± 0,75 µm



Steel



Inserted into a light alloy, blue coloured ring for easier handling. Also with engraved nominal diameter.



Inspection report from 2 mm available on request



EN ISO 1938
Factory standard

5 ÷ 10 mm dia.:
± 1,25 µm
10 ÷ 18 mm dia.:
± 1,5 µm
18 ÷ 29,99 mm dia.:
± 2 µm

Steel

Inserted into a light alloy, grey coloured ring for easier handling. Also with engraved nominal diameter

Inspection report available on request

TESA CARY Steel Ring Gauges, Diameters 5 to 30 mm, Type BOMa

Type BOMa, 1 steel ring gauge.

Type BBOMa, 2 BOMa steel ring gauges mounted in pairs on plates for use as GO/NO GO type gauges.

No	=	∅	A
		mm	Step, µm
CJ1BOA1	BOMa	5,00 ÷ 9,99	1
CJ1BOA2	BOMa	10,00 ÷ 11,99	1
CJ1BOA3	BOMa	12,00 ÷ 13,99	1
CJ1BOA4	BOMa	14,00 ÷ 15,99	1
CJ1BOA5	BOMa	16,00 ÷ 17,99	1
CJ1BOA6	BOMa	18,00 ÷ 19,99	1
CJ1BOA7	BOMa	20,00 ÷ 22,99	1
CJ1BOA8	BOMa	23,00 ÷ 25,99	1
CJ1BOA9	BOMa	26,00 ÷ 29,99	1
CJ1BBA1	BBOMa	5,00 ÷ 9,99	1
CJ1BBA2	BBOMa	10,00 ÷ 11,99	1
CJ1BBA3	BBOMa	12,00 ÷ 13,99	1
CJ1BBA4	BBOMa	14,00 ÷ 15,99	1
CJ1BBA5	BBOMa	16,00 ÷ 17,99	1
CJ1BBA6	BBOMa	18,00 ÷ 19,99	1
CJ1BBA7	BBOMa	20,00 ÷ 22,99	1
CJ1BBA8	BBOMa	23,00 ÷ 25,99	1
CJ1BBA9	BBOMa	26,00 ÷ 29,99	1



Ring gauges sizes BOMa

∅	Ring gauges	Outer rings			
A mm	B mm	C mm	D mm	E mm	F mm
5 ÷ 10	18	2	30	4	10,5
10 ÷ 14	24	2,5	38	5	15
14 ÷ 18	30	3	46	6	19
18 ÷ 24	38	3,5	56	8	25
24 ÷ 30	46	4	68	8	31

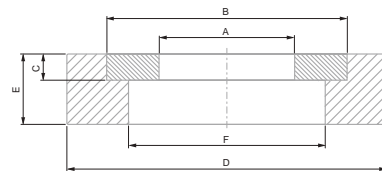

EN ISO 1938
Factory standard

∅ 5 ÷ 10 mm:
± 1,25 µm
∅ 10 ÷ 18 mm:
± 1,5 µm
∅ 18 ÷ 29,99 mm:
± 2 µm
Better quality upon request (Q5)
∅ 5 ÷ 10 mm: ± 1 µm
∅ 10 ÷ 18 mm: ± 1,2 µm
∅ 18 ÷ 29,99 mm: ± 1,5 µm

Tungsten carbide

Inserted into a light alloy, grey coloured ring for easier handling. Also with engraved nominal diameter.

Inspection report available on request

TESA CARY Tungsten Carbide Ring Gauges, Diameters 5 to 30 mm, Type BOMm

Type BOMm, 1 Tungsten carbide ring gauge.

Type BBOMm, 2 BOMm carbide ring gauges mounted in pairs on plates for use as GO/NO GO plug gauges

No	=	∅	A
		mm	Step, µm
CJ1BOM1	BOMm	5,00 ÷ 9,99	1
CJ1BOM2	BOMm	10,00 ÷ 11,99	1
CJ1BOM3	BOMm	12,00 ÷ 13,99	1
CJ1BOM4	BOMm	14,00 ÷ 15,99	1
CJ1BOM5	BOMm	16,00 ÷ 17,99	1
CJ1BOM6	BOMm	18,00 ÷ 19,99	1
CJ1BOM7	BOMm	20,00 ÷ 22,99	1
CJ1BOM8	BOMm	23,00 ÷ 25,99	1
CJ1BOM9	BOMm	26,00 ÷ 29,99	1
CJ1BBM1	BBOMm	5,00 ÷ 9,99	1
CJ1BBM2	BBOMm	10,00 ÷ 11,99	1
CJ1BBM3	BBOMm	12,00 ÷ 13,99	1
CJ1BBM4	BBOMm	14,00 ÷ 15,99	1
CJ1BBM5	BBOMm	16,00 ÷ 17,99	1
CJ1BBM6	BBOMm	18,00 ÷ 19,99	1
CJ1BBM7	BBOMm	20,00 ÷ 22,99	1
CJ1BBM8	BBOMm	23,00 ÷ 25,99	1
CJ1BBM9	BBOMm	26,00 ÷ 29,99	1



Ring gauges sizes BOMm

∅	Ring gauges	Outer rings			
A mm	B mm	C mm	D mm	E mm	F mm
5 ÷ 10	18	2	30	4	10,5
10 ÷ 14	24	2,5	38	5	15
14 ÷ 18	30	3	46	6	19
18 ÷ 24	38	3,5	56	8	25
24 ÷ 30	46	4	68	8	31

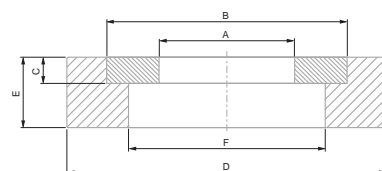

Accessories for Plug Gauges



No	=
CJ1ED25N	Wooden case for 25 TDH plug gauges
CJ1EL25N	Wooden case for 25 TLH plug gauges
CJ1XDL	Plastic case for TDH/TLH/TXH plug gauges
CJ1PTXK	Box for 50 plugs 0,300 ÷ 1.509 mm
CJ1MTXK	Box for 50 plugs 0,510 ÷ 3.509 mm
CJ1GTXK	Box for 50 plugs 3,510 ÷ 10,000 mm
CJ1N50	Suited clear box for 50 PNH thread wires
CJ1N3	Carrying tube for 3 PNH thread wires
CJ1NGC	Box engraving for each diameter
CJ1NLSM	Thread wire alone, without handle
CJ1CEB3	Suited case for 3 rings from Ø 0,06 ÷ 1,50 mm
CJ1CB40	Suited case for 12 rings from Ø 1,50 ÷ 2,50 mm
CJ1CB24	Suited case for 24 rings from Ø 2,50 ÷ 4,00 mm
CJ1CB18	Suited case for 12 rings from Ø 4,00 ÷ 5,00 mm
CJ128021010A	Aluminium resting plate for 2 rings from Ø 0,06 ÷ 1,50 mm
CJ128021011A	Aluminium resting plate for 2 rings from Ø 1,51 ÷ 2,50 mm
CJ128021012A	Aluminium resting plate for 2 rings from Ø 2,51 ÷ 4,00 mm
CJ128021013A	Aluminium resting plate for 2 rings from Ø 4,01 ÷ 5,0 mm
CJ1BAA	Bearing ring (one for each ring gauge from Ø 0,06 ÷ 5,00 mm)
CJ1CEB4	Suited case for 4 rings from Ø 0,06 ÷ 1,50 mm
CJ1EB12	Suited case for 12 rings from Ø 0,06 ÷ 1,50 mm
CJ1BBA	Resting ring (one item for each ring gauge from Ø 5,00 ÷ 30,00 mm)



Calibration Equipment

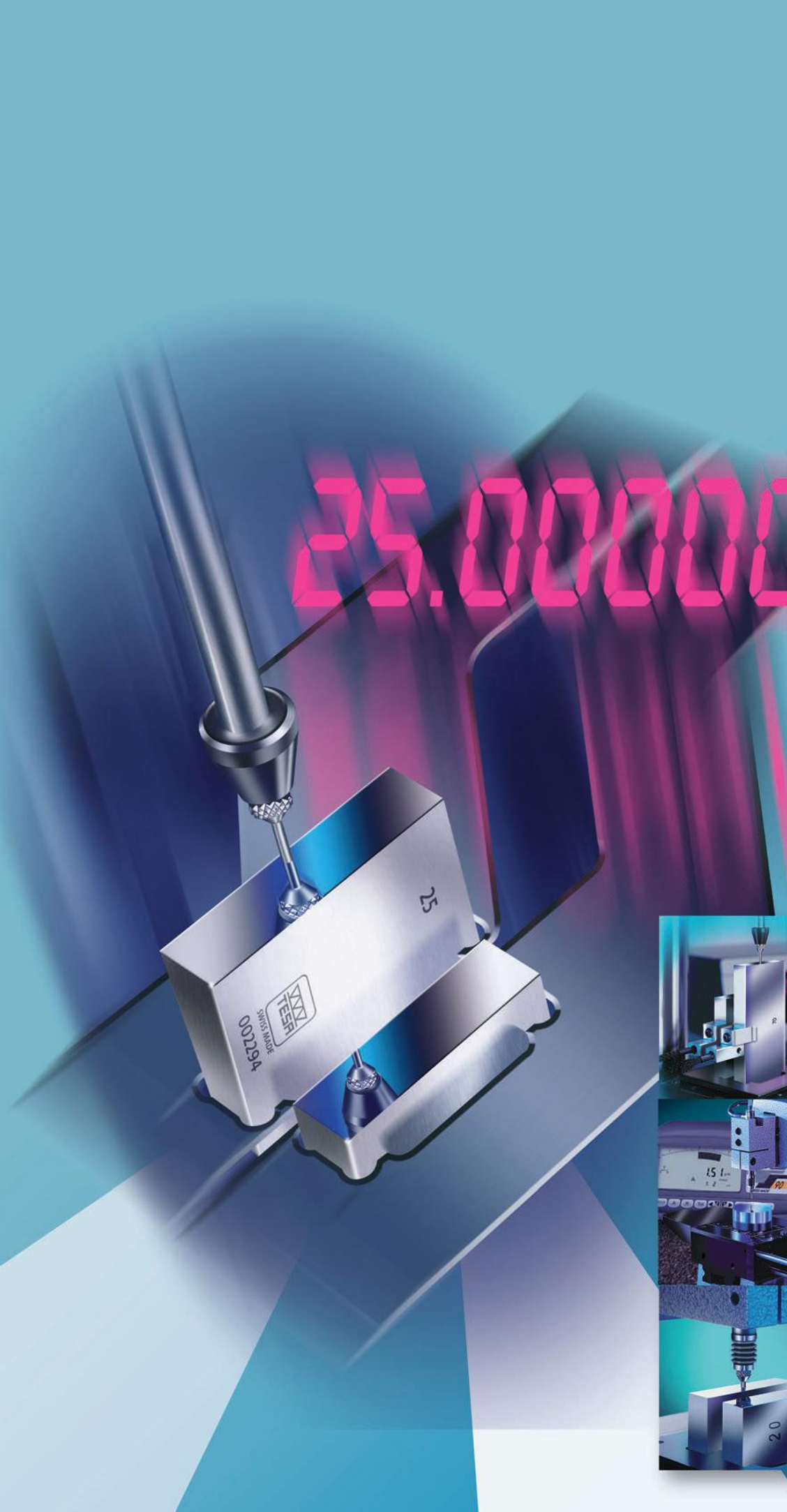

CONFIDENCE IS NOT ENOUGH...

The control of inspection and measuring equipment is an element of quality management that is now more important than ever before. The introduction of the ISO 9000 family of international standards has also led to major changes in this field. Amongst other things, ISO 9001 specifies that : "all inspection and measuring equipment that can affect product quality must be identified, calibrated and adjusted at prescribed intervals, or prior to use, against certified equipment having a known valid traceable relationship to internationally or nationally recognised standards".

This standard also states that the supplier shall: "ensure that the inspection and measuring equipment is capable of the necessary accuracy and precision".

A Vast Choice

TESA can offer you the most varied methods of measurement specifically suited for the inspection and calibration of standards, handtools and plug gauges. Some of these are described in the various sections of this catalogue, in particular:

- Gauge blocks
- Setting rings
- Cylindrical setting standards with outside diameters
- Optical flats
- Parallel optical flats
- Electronic levels for both straightness and flatness measurement
- Instruments for both squareness and perpendicularity measurement
- Calibration equipment for length measuring devices fitted with inductive probes.



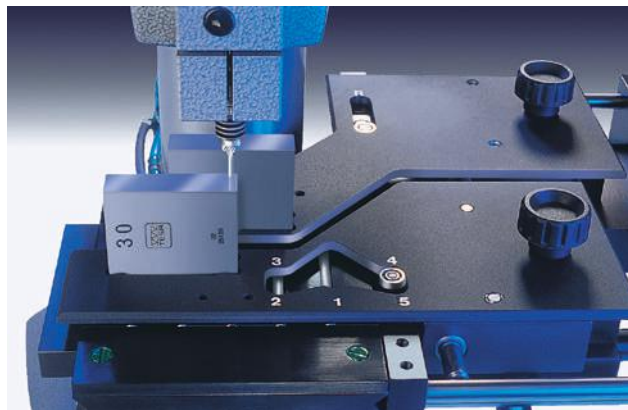
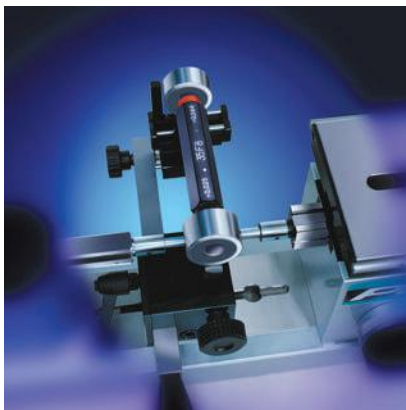



This section is devoted to measuring systems that serve to calibrate other inspection equipment, but they can also be used for high-accuracy measurement of precision parts.

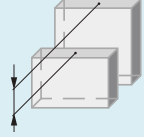
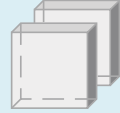

PRESENTATION OF TESA MEASURING GAGE BLOCKS

TESA offers two models, the operation of which is based on two different measurement procedures.

- TESA UPD directly measures gauge blocks within a measuring span of 25 mm/1 in.
- TESA UPC is used for comparative measurement of gauge blocks having a same nominal length.

TESA Gauge Block Comparators		UPD	UPC
	Measuring procedures <ul style="list-style-type: none"> - Comparison of different nominal lengths up to 25 mm - Number of reference gauge blocks required for the calibration of a set of 122 pieces: 9 blocks - Number of blocks required for the calibration of the device: 9 blocks + 6 pairs 		● ● ●
	Comparative measurement <ul style="list-style-type: none"> - Comparison of gauge blocks having the same nominal length - Number of reference gauge blocks required for the calibration of a set of 122 pieces: 122 blocks - Number of gauge blocks required for the calibration of the device: 6 pairs 		● ● ● ● ● ●
	Measuring errors Read also the explanations provided in this same chapter with regard to the measuring errors of each instrument		
	Repeatability limit	0,015 µm 0,025 µm	● ● ●
	Measuring uncertainty	$U = \pm (0,05 + 0,5 \cdot L) \mu\text{m L in m}$ $U = \pm (0,10 + 1,0 \cdot L) \mu\text{m}$	● ● ●
	Range of application Nominal lengths	0,5 to 100 mm/0.02 to 4.0 in 0,5 to 500 mm/0.02 to 20 in	● ● ▲ ▲
	Measuring range 25 mm/1 in		●
	Sensors for capturing length dimensions <ul style="list-style-type: none"> - 2 axial probes in sum measurement - Digital measuring system, opto-electronic with incremental divisions - Analogue measuring system, electronic and inductive - Activation of the measuring force <ul style="list-style-type: none"> • electro-motorised • by spring force - Retraction of the measuring bolt <ul style="list-style-type: none"> • electro-motorised • by vacuum 		● ● ● ● ● ● ● ● ● ●
	Template system <ul style="list-style-type: none"> - Single template system - Dual template system 		● ● ● ○
	Positioning of gauge blocks with a nominal length of up to 10 mm Suction loader with an electric vacuum pump		○ ○
	TESA UPT temperature measuring device Measurement of the electrical resistance using 4 thermal sensors (4 wire type)		● ○
	TESA software for processing the measured values <ul style="list-style-type: none"> - TESA UP, WINDOWS 98, 2000, NT, XP, 7 (32 bits) 		● ●
▲ Available on request ○ Recommended option			



GAUGE BLOCK COMPARATORS

In the hierarchical chain of dimensional measurements that can be traced back to the standard metre length unit, gauge blocks hold a key position. This makes them the most important material references used in metrology.

The application of the length unit, based on specific wavelengths of light, to gauge blocks is achieved in the first instance by fundamental interferential measurement. Using gauge blocks measured by interferometry, defined lengths are thus transferred to other gauge blocks in measurements further down the hierarchical chain.

TESA UPD – for Direct and Comparative Measurements

- Direct measurement of gauge blocks with a variation in nominal length of up to 25 mm or 1 in.
 - Enables the number of reference gauge blocks required to be reduced by nearly 80 %.
- Comparative measurement of gauge blocks having a same nominal length.
 - Enables lower measurement uncertainties to be achieved due to weaker influences of the systematic errors.
- Equipped with HEIDENHAIN high-precision incremental probes.
- Templates with a new concept for positioning the gauge blocks.
 - Single or dual template system to provide optimum ease of handling of the gauge blocks
- Integrated device for most accurate temperature acquisition.
- On-line transfer of both measured length and temperature values.
- Computer-aided data processing with all the corrections necessary included.

Dual template system for the maintenance of your reference gauge blocks (TESA patented)

- The simultaneous use of two templates allows you to "rest up" your gauge blocks until you need them.
- The application of this new concept turns into significant savings in both time and money.
- During measurement cycles carried out on a routine basis, the distance travelled over the measuring table is reduced by nearly 70 %.
 - This contributes to significant reductions of the risks of damaging and wearing the measurement faces.
- The double protection of your reference gauge blocks leads to significant cost savings through the reduction if the need for:
 - recalibration
 - restoration of the measuring faces
 - replacement of worn or damaged gauge blocks
 - increased downtime (whilst extending the life of your reference gauge blocks)

Single Template System

- Using this system your reference gauge blocks are moved together with those to be calibrated during the measurement cycles.



EN ISO 3650
(ASME B89.1.9-2002 on request)



For gauge blocks with nominal lengths from 0,5 mm to 100 mm / 0.02 in to 4 in



Measuring configuration
Two probes with mechanical contact with the measuring face to be probed are connected in sum measurement (function +A+B).

Measuring points
On the reference gauge block: at the centre of the measuring face (point R). On the gauge block to be measured: at the centre (point 1) as well as the four corners of the measuring face, each lying 2 mm away from the adjacent faces (points 2 to 5).

The central length l_c is determined by probing both points R and 1. For establishing lengths at any point, the measurements shall be carried out at points R plus 1 to 5.

The variation in length v is obtained from measurements taken at points 1 to 5.



Packed suitable for shipping



Identification number



Calibration certificate from the supplier for the comparator or the Swiss Calibration Service for the temperature device.

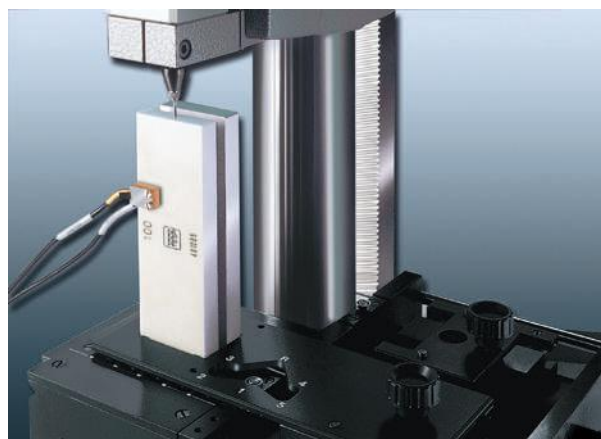
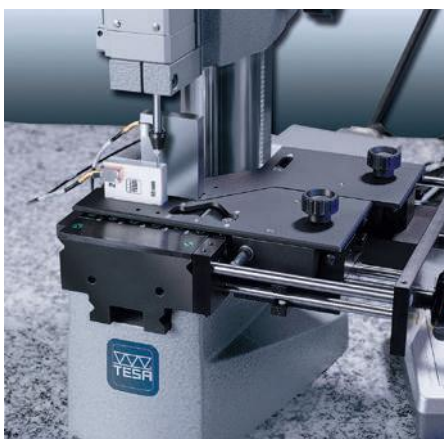

2 different delivery programs

No	=		
05930005		TESA UPD gauge block comparator with temperature device*	•
05930004		TESA UPD gauge block comparator without temperature device	•
CONSISTENT OF:			
05930008		TESA UPD mechanical part	• •
05960016		HEIDENHAIN computing counter ND 287 featuring 2 probe inputs	• •
05960013		Control panel	• •
05960014		Connecting cable for control panel to ND 287 computing counter	• •
04768001		Foot switch	• •
01660011		Suction loader	•
03260433		Electrical vacuum pump with external control, 230 VAC, 50 Hz	•
05960028		Connecting cable for electronic vacuum pump to control panel	•
05930011		TESA UPT temperature device, complete	•
Other delivery program available on request			
* Special execution for 110 VAC, 60 Hz also available on request (ref. S32070030 instead of 03260433)			

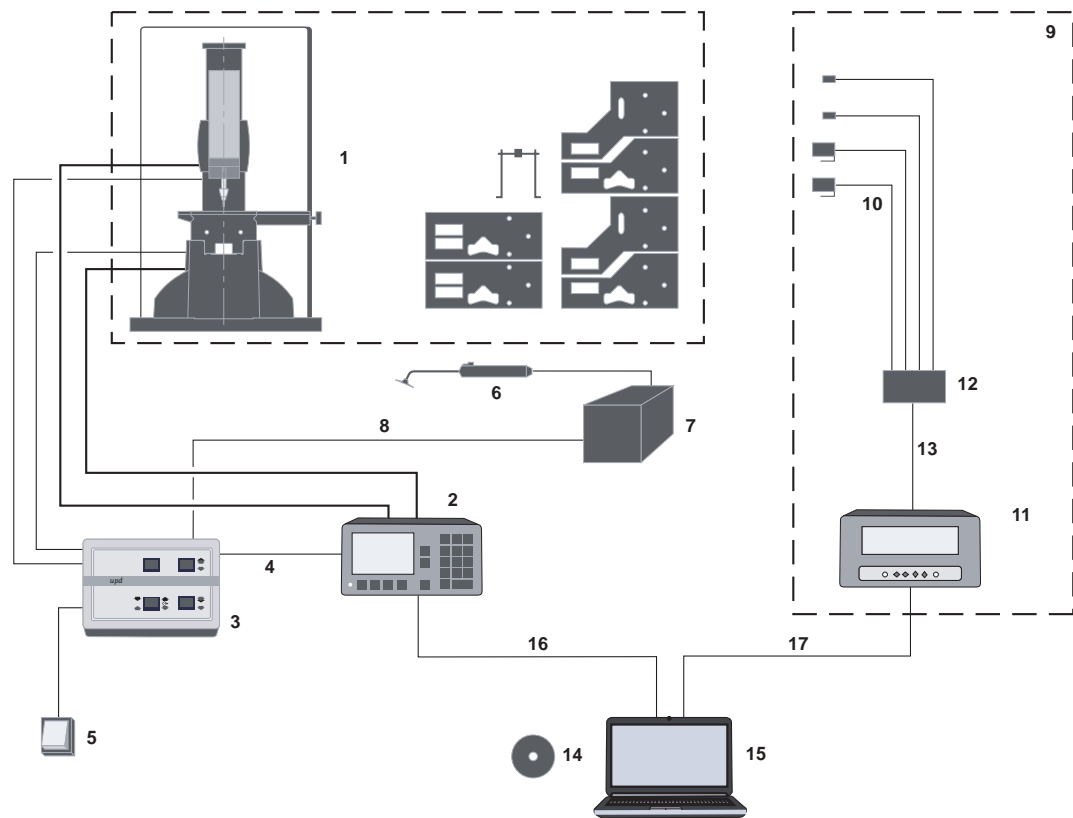

Errors of Measurement

Provided all metrological conditions are met, the reliability of the comparator used for direct measurement of steel gauge blocks is expressed as follows:

- 

Repeatability limit (with no influence of external temperature): 0,015 µm
- 

Uncertainty of measurement: $U = \pm (0,05 + 0,5 \cdot L) \mu\text{m}$ (L in m)
- 

Condition requires the use of reference standards whose measurement uncertainty is equal to:
 $U \leq \pm 0,015 \mu\text{m}$ for the comparator
 $U \leq \pm (0,02 + 0,2 \cdot L) \mu\text{m}$ (L in m) for the gauge blocks



TESA UPC – for Comparative Measurement

TESA UPC Gauge Block Comparator for Comparative Measurement

- Measures gauge blocks of same nominal length by comparison.
- Comes with the new template system for positioning the gauge blocks.
- Single or dual template system for optimum ease of gauge handling.
- Features TESA high-precision inductive probes.
- Allows ultra-precise temperature measurement, integrated.
- Transfers on-line all measured length and temperature values.
- Executes computer-aided data processing with all required correction values included.
- Performs calibrations that meet the requirements of both ISO standards and EA guidelines (EAL – European cooperation for Accreditation of Laboratories).
- Includes an execution for greater accuracy along with a calibration certificate (optional).



TESA UPC is specially designed for the calibration – or dimensional inspection – of gauge blocks with nominal lengths ranging from 0,5 to 100 mm. The configuration, which consists of two probes aligned opposite one another, associated with both the concept and quality of the measuring system provides full guarantee for an extra low uncertainty of measurement. Although TESA UPC is mainly intended for manufacturers and end-users of gauge blocks, this comparator is also widely used in nationally accredited laboratories.



If specified, TESA can also provide the temperature device available as an option. This device has 4 PT100 platinum resistances, each capturing the temperature of the two gauge blocks along with that of both the measuring table and the support. Computer-aided data processing lets you carry out any calibration most reliably and rationally – for sure.



EN ISO 3650



For gauge blocks ranging from 0,5 mm to 100 mm or 0.02 in to 4 in (0,5 to 500 mm on request)



Comparative measurement procedure with transference of the length of a reference gauge block to the gauge block being measured. Measuring configuration 2 probes connected in sum measurement (function +A+B) with mechanical contact with the measuring face.

Measuring points
On the reference gauge block: at the centre of the measuring face (point R). On the gauge block to be measured: at the centre (point 1) as well as the 4 corners of the measuring face, each lying 2 mm away from the adjacent faces (points 2 to 5).

Central length l_c is defined by probing both points R and 1.

Establishing lengths at any point requires measurements to be taken at points R plus 1 to 5.

Variation in length v is the result of measurements taken at points 1 to 5.



≈ 23 kg (comparator complete, but without computer).
≈ 4 kg (temperature device)



Packed suitable for shipping



All instruments with the option for greater accuracy are delivered with serial numbers



In-house calibration certificate for the version with greater accuracy or declaration of conformity for the standard version. Temperature device with SCS certificate.



No	=				
TESA UPC GAUGE BLOCK COMPARATOR EQUIPPED WITH SINGLE TEMPLATE SYSTEM					
05930000	Standard execution without computer application				●
05930003	Execution for greater accuracy, with computer application			●	
TESA UPC GAUGE BLOCK COMPARATOR EQUIPPED WITH SINGLE AND DUAL TEMPLATE SYSTEM					
05930013	Execution for greater accuracy without computer application		●		
05930015	Execution for greater accuracy, with computer application	●			
EACH VERSION CONSISTS OF:					
01610401	TESA UPC mechanical part equipped with the single template system			●	●
05960030	TESA UPC mechanical part equipped with both single and dual template system	●	●		
03260401	Pneumatic retraction of the measuring bolt, manually operated				●
03260432	Electric vacuum pump with foot switch		●		
03260433	Electric vacuum pump with external control	●		●	
01660011	Pneumatic suction loader	●	●	●	
04430012	TESATRONIC electronic unit TT90	●	●	●	●
05960039	Set of TESA UPC accessories, including the components 04761049, 04760087 and 04761070				
04761049	Opto-RS cable, bidirectional	●		●	
04760087	Opto-RS interface	●		●	
04761070	Connecting cable TESATRONIC TT90 to vacuum pump	●		●	
04768000	Hand switch	●		●	
01690021	Option for greater accuracy with calibration certificate	●	●	●	

Error of Measurement

Provided all the metrological conditions are met, the reliability of the two standard executions No. 05930000 and 05930002 is expressed as follows:

Provided all the metrological conditions are met, the reliability of both executions No. 05930001 and 05930003 along with the option for greater accuracy (No. 01690021) is expressed as follows:

Repeatability limit (with no effect due to external temperature): 0,025 µm

Repeatability limit (with no effect due to external temperature): 0,015 µm

Measurement uncertainty*
 $U = \pm (0,10 + 1,0 \cdot L) \mu\text{m}$ (L in m)

Measurement uncertainty*
 $U = \pm (0,05 + 0,5 \cdot L) \mu\text{m}$ (L in m)

Condition involves the use of reference standards (see page L-14 and L-15) whose uncertainty is as follows:
 $U \leq \pm 0,030 \mu\text{m}$
 when calibrating the comparator
 $U \leq \pm (0,05 + 0,5 \cdot L) \mu\text{m}$ (L in m)
 when calibrating the gauge blocks

Condition involves the use of reference standards (see page L-14 and L-15) whose uncertainty is as follows:
 $U \leq \pm 0,015 \mu\text{m}$
 when calibrating the comparator
 $U \leq \pm (0,02 + 0,2 \cdot L) \mu\text{m}$ (L in m)
 when calibrating the gauge blocks

* Applicable to steel gauge blocks

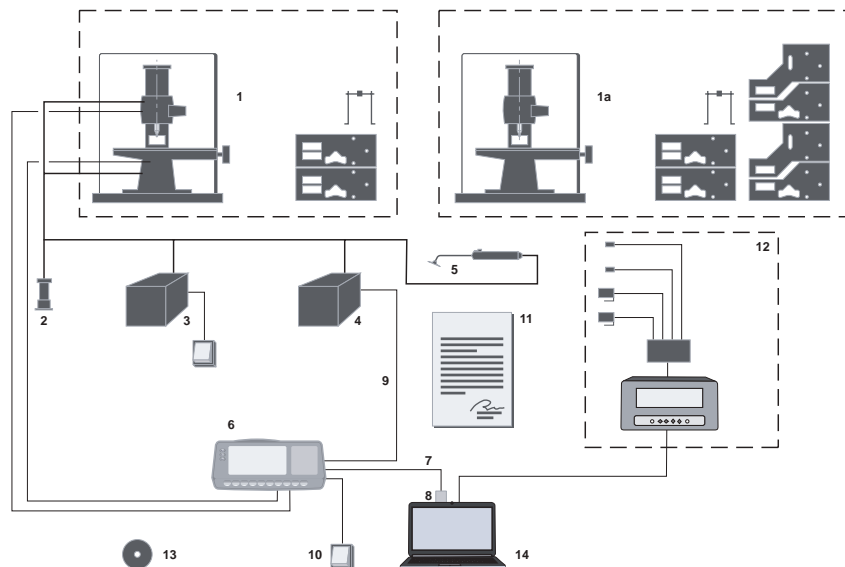

TESA UP – Software Programme for Value Processing

TESA UP programme for processing measured values suitable for both TESA gauge block comparators UPD and UPC as well as for comparators from other manufacturers.

- Choice of 10 languages.
- On-line processing of length and temperature values as transferred.
- Measurement cycles and result outputs according to EN ISO 3650.
- Flexible architecture for optimum adaptation to specific user's needs.
- Possible entry of limit values and accuracy grades peculiar to users.
- Surveillance of value dispersion or value drift throughout length and temperature measurements.
- Automatic execution of all relevant corrections. The programme makes allowances for actual sizes of the reference standards, flattening due to different materials used (steel, tungsten carbide, ceramic), compensation of temperature variations with reference to 20°C according to the varying coefficients of linear expansion – as typical examples.
- Assignment of gauge blocks to their relevant grade.
- Possible storage of gauge block set related data.
- Inch or metric value processing.
- Calibration certificate in several formats.



05960025	TESA UP software programme for gauge block calibration	1 CD-ROM plus 1 USB key of protection

Gauge Blocks for the Calibration of Comparators

To calibrate both TESA gauge block comparators UPD and UPC, we recommend the use of the gauge block set described hereafter. The 9-piece set is also required for calibrating TESA UPD.

Set composition including 11 gauge blocks.

Each pair is in full compliance with:

- EAL-G21 – Calibration of gauge block comparators – European cooperation for Accreditation of Laboratories
- DKD-R 4-1 – Guidelines of the German Calibration Service (DKD) for the calibration of gauge block comparators.

S59110152	Set of 11 gauge blocks with PTB (Physikalisch Technische Bundesanstalt) certificate	$\pm 0,015$ μm
S59110489	Set of 11 gauge blocks with DAkkS certificate	$\pm 0,030$

Full tungsten carbide set also available on request

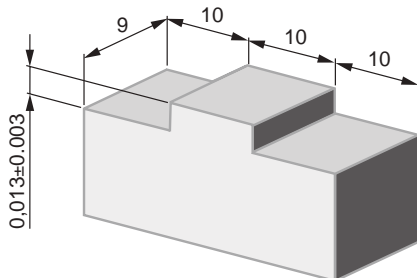

Pairs N°	Nominal length	
	A mm	B mm
1	0,5	0,5
2	1,0	1,005
3	1,0	1,01
4	4,5	4,5
5	100,0	100,0
6	6,0	6,0 *

* Special bridge-shaped gauge blocks (see drawing) used for establishing the measuring deviations of lower probe B.

- EN ISO 3650
- Minimum profile requirements for the computer needed to run the TESA UP software programme Personal Computer
 - Configuration without heat source to avoid disturbing the ambient temperature at the measurement spot
 - Operating system: Windows 7 or earlier versions (32 bits)
 - Processor: 650 MHz
 - 1 Hard disc (6 GB)
 - RAM capacity: 64 MB
 - CD-ROM drive (24x)
 - RS232 serial port
 - 1 for length values
 - 1 for temperature values
 - 3 USB ports
- mm/In units

- EN ISO 3650
- Special high-alloy steel, wear resistant and stable. Exception: 6 mm special carbide gauge blocks.
- Wooden case
- PTB or DKD calibration certificate
- Serial number identification
- The given expanded uncertainty $k = 3$ refers to the difference of central length of both gauge blocks A and B forming the pairs 1 to 5 as well as to the deviations f_0 and f_u from the central length of gauge blocks forming both pairs 2 and 3. No need to calibrate those of pair No. 6.
- Class K



EN ISO 3650



Special high-alloy steel wear resistant and stable



Wooden case



For calibration certificates, see opposite



Serial number identification

Expanded uncertainty $k = 2$ is valid for that given



Grade K



Additional Gauge Block Set for Calibration of the TESA UPD System

In order to achieve the lowest uncertainty of measurement, we recommend the use of grade K gauge blocks which have been measured directly by interferometry and are supplied with a calibration certificate, irrespective of any other requirement such as the ambient conditions.

No	=	
S59300103	Set 9 gauge blocks with METAS certificate (Swiss)	$\pm 0,02 + 0,2 \cdot L \mu\text{m}$ (L in m)
S59300107	Set 9 gauge blocks with PTB certificate (Germany)	$\pm 0,02 + 0,2 \cdot L \mu\text{m}$ (L in m)
S59300104	Set 9 gauge blocks with SCS certificate	$\pm 0,05 + 0,5 \cdot L \mu\text{m}$ (L in m)

	Set composition (mm) 1 / 5 / 10 / 15 / 20 / 25 / 50 / 75 / 100
	Steel
	Accuracy grade K

Other set composition or carbide gauge blocks also available on request.

TESA UPT

Fully calibrated for the measuring ranges from 19°C up to 24°C with a numerical interval to 0,001°C.

Supplied with a calibration certificate issued by the Swiss Calibration Service (SCS). Uncertainty of measurement achieved during calibration $U = \pm 0,03^\circ\text{C}$.

No	=
05930011	Temperature measurement device
CONSISTING OF:	
05960018	Set of 4 temperature sensors PT 100
05960038	Measuring unit for temperature, FLUKE 1529
05960012	Interface Box 4 x PT 100
05960011	Connecting cable for adapter No. 05960012 to measuring unit No. 05960038
05960026	Connecting cable from UPC to computer (9-pin/m and 9-pin/f connector)



ETALON POLO HORIZONTAL MEASURING BENCH

A giant for small sizes – Specially designed for the control of measuring and test equipment in compliance with ISO 9000.

- Application range from 0 up to 100 mm for external dimensions of 2,5 up to 110 mm for internal dimensions – 50 mm measuring span.
- Resolution to 0,001 or 0,0001 mm – Metric/Inch conversion.
- Maximum permissible error of 0,5 µm.
- Measuring force from 0 to 4 N.
- Comes with a calibration certificate issued by the supplier.



Calibration of Standards:

- Cylindrical test pins
- Setting standards with cylindrical, plane-parallel measuring faces
- Threaded reference gauges (calibrated using the 3-wire method)
- Setting masters
- Setting rings

Workpiece Inspection:

External dimensions

- Stepped shafts
- Cutting tools
- Cylindrical pins
- Ball tips
- Grooves
- Short centring shoulders
- Threads (measured according to the 3-wires method)

Internal dimensions

- Through bores
- Blind bores
- Centring grooves
- Slots
- Sliding guides

Calibration of Plus Gauges:

- Limit plug gauges
- Plug gauges "GO"
- Plug gauges "NO GO"
- Plain plug gauges
- Ring gauges "GO"
- Ring gauges "NO GO"
- Threaded plug gauges

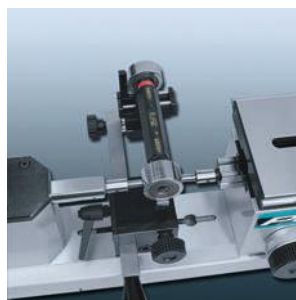
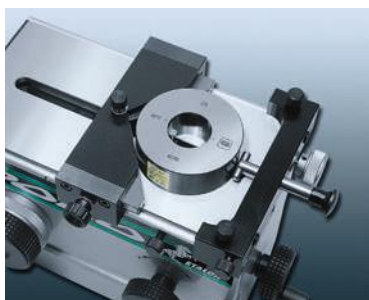



Max. perm. error within the measuring span: 0,5 µm with standard accessories



0,1 µm



Opto-electronic measuring system with incremental glass scale, type LIF - HEIDENHAIN



Tilting range of the floating table ± 0,5°



-10°C to 40°C



10°C to 40°C



EN 50081-1
EN 50082-2
EN 61000-4-2
EN 61000-4-4



Setting 0 to 4N



50 mm measuring span



19 kg net (main part alone, without table). Floating table: 2,8 kg net



8,0 • 10-6/°C



• 0 to 100 mm for external dimensions
• 10 to 110 mm with standard accessories
• 2,5 to 110 mm with optional accessories

ETALON POLO with Floating Resting Table

Calibration of measuring instruments

- Dial Gauges
- Lever Dial Test Indicators
- Electronic transducers



No

=

05939001 ETALON POLO measuring bench with floating table and electronic computing counter

CONSISTING OF:

05919002 Main part
05969024 1 pair of inserts for external dimensions
05969015 Floating measuring table
05969029 HEIDENHAIN computing counter ND 287

DELIVERED WITH THE FOLLOWING ACCESSORIES:

05969020 1 Pair of standard inserts for internal dimensions from 10 mm
05969030 Protective cover



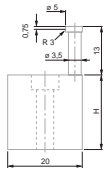

05969020

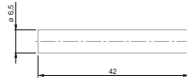

05969024

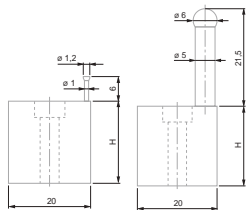

05969021

05969022

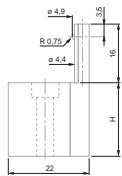

05969023

Pair of Standard Measuring Inserts for External and Internal Dimensions from 10 mm

No	=	Description
05969020		1 Pair of standard inserts for internal dimensions from 10 mm
05969024		1 pair of inserts for external dimensions

To be used with floating table N° 05960015, H = 20 mm

6,5mm Ø carbide inserts with a flat face



Packed suitable for shipping

Measuring Inserts for Internal Measurement used with the Floating Resting Table

Height H = 20 mm. M4 locking screw.

No	=	Description
05969021		Internal measuring inserts from 2,5 mm
05969022		Internal measuring inserts from 13 mm
05969023		Internal measuring inserts from 5 mm

Barrel-shaped inserts with a 1,2 mm dia. carbide ball tip.

Fitted with a 6 mm dia. carbide ball tip.

Fitted with a 1,5 mm dia. carbide ball tip.



Bench Stand with Swivelling Plate

For raising the measuring bench from horizontal to vertical position. Accommodates a clamp lever. Length (upright): 295 mm, mass ≈ 20 kg.

No	=	Description
05969000		Bench stand with swivelling plate



Base for the Computing Counter

Base for raising up the HEIDENHAIN ND 287 counting unit, height 380 mm, weight 5,2 kg.

No	=	Description
05969001		Stand for computing counter

Floating Resting Table

Used for external measurement on oblong parts up to 60 mm in diameter; centres, L=160 mm; movable positioning fixture for parts having varying lengths, 3 freedom degrees.



No	=	Description
05969032		Resting table without vise
05969033		Vise for plug gauges
05969034		Floating table

Stands for Checking External Dimensions



No	=	Description
05969007		Ø 3 mm stand for external Ø
05969008		Ø 6 mm stand for external Ø

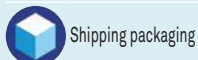

Stand with Ø 10 mm Fixing Bores

For H-shaped table (05969003) and for control system for lever-type indicator (05969004)



05969002 Stand with Ø 10 mm bore for 05969003 and 05969004

Centering Device

Allows the user to search for the transverse culmination point against the measuring direction. Used with either the fixed or floating table No. 05969014 or 05969015. Prismatic stop adjustable transversely, max. diameter 110 mm. Counter pressure piece finished with cylindrical stop pins.



05969012 Centering device for culmination point

Fixing Shank

For clamping the instruments that need to be calibrated such as dial gauges or precision indicators etc.



059690010



05969010 For fixing shafts with a Ø 8 mm

05969011 For fixing shafts with a Ø 3/8 in

Holder for a Dial Test Indicator (Lever-type)

Provided with 2 dovetail clamps, TESATAST-type or in compliance with BS 2795:1981



05969004 Holding device for test indicator

Spindle for Calibrating Dial Gauges, Dial Test Indicators and such like

Setting range = 50 mm, Spindle rotation = 0,5 mm



05969009 Spindle for calibrating dial gauges, dial test indicators and such like





Surface Roughness Testing



THE ROUGHNESS PARAMETERS MOST COMMONLY USED ARE: RA, RZ AND RMAX

TESA RUGOSOFT and MEASUREMENT STUDIO Software

These software tools allow the storage of surface roughness measurements along with roughness parameters and roughness profile. A measuring programme created in the software can be transferred to the instrument together with measuring parameters. The results are available at all times, complete with statistical analysis and can be exported for reports, for example.

Mean roughness Ra (ISO 4287, DIN 4768)

The mean roughness Ra matches the arithmetical mean of the absolute values related to the profile deviation y within the reference length l.

Max. profile valley depth Rmax (DIN 4768)

The max. profile valley depth Rmax is for the most significant single roughness depth Zi within the total length lm.

According to ISO 4288 and DIN 4287 - Part 1, this parameter is also specified as Ry max.

Mean roughness depth Rz DIN (DIN 4768)

The mean roughness depth Rz is the arithmetical mean of single roughness depths of successive sampling lengths le. According to ISO 4287 and DIN 4762, the parameter Rz DIN is also specified as Ry5.

Since Rz changes its name in both DIN 4768 and ISO 4287, this parameter is also specified as Rz DIN or Rz ISO. If the parameter Rz is measured according to DIN, it is generally admitted that the extreme value specified by ISO is matched providing that Rz ISO does not exceed Rz DIN.

Use of Roughness Comparison Specimens

These specimens are used for testing any surface finish quality and have long proven their value in practice.

They are used for touch and/or sight comparisons against the surface of work pieces that are produced using the same manufacturing process. The condition is that materials have to be comparable.

When comparing the workpiece surface against the specimen, roughness is not quantitatively expressed. The assessment of the extent to which the surface finish of both is alike can only be subjective.

Sight comparison requires optimum light source angle. For small surfaces, the use of a magnifying glass with up to 8x magnification is recommended.

Touch comparison is made using the finger tip or a small copper piece such as a coin, for instance.



RUGOSURF 20



RUGOSURF 90G in profile measuring mode with PROFILE SET 2 mm

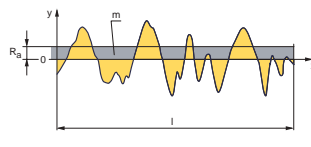
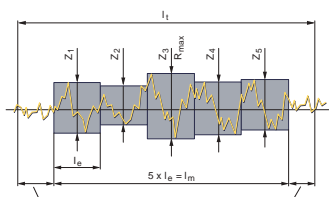

RUGOSURF 20 with dot matrix printer



RUGOSURF 90G



RUGOSURF 20, RUGOSURF 10G, RUGOSURF 90G ROUGHNESS GAUGES

TESA offers a range of 3 portable RUGOSURF roughness gauges adapted for different levels of precision from the production floor to the test laboratory.

These devices are particularly appreciated by operators for their ease of use, robustness and reliability.

The range includes data management software to process measured values for an optimal overview of roughness profiles, statistical data and customizable measurement reports.



RUGOSURF 20



RUGOSURF 10G



RUGOSURF 90G



TESA RUGOSURF 20

Portable roughness gauge, robust and versatile.
Well suited for production environments or inspection of inward goods.

Measures roughness parameters according to:

- ISO 4287
- JIS B0601
- DIN and ISO 12085 (MOTIF or CNOMO).

Measuring range in the Z-axis of 400 μm (6300 μin).

15 roughness parameters.

Each parameter can be activated individually or not.

Possible tolerancing of parameter values.



Scope of supply

Direct display:

- of all measured values, with tolerance levels display,
- of R roughness profile,
- the Bearing Area Curve (BAC),
- the Amplitude Distribution Curve (ADC).



With a measuring stand with suction base

2" Black&White LCD screen, high contrast for optimum visual representation.

Flexible autonomy through mains adapter or battery pack.

Storage of the measured parameters.

Multilingual menu options.

USB cable connection (optional).

Direct printing to a dot matrix printer (optional).

Measurement transfer, database creation and reporting available using TESA RUGOSOFT software tool (optional).



Measurement of narrow hard to reach crevices thanks to the 100 mm probe extension

Access to narrow and hard to reach locations possible through 100 mm probe extension (optional).



With vertical positioning support



Description:

1. Start / Measure
2. Probe protection
3. LCD 2" screen
4. Enter key
5. Defilement key
6. Return key / Measurement parameters
7. ON/OFF Switch
8. Batter charger connector
9. USB Connector for PC
10. Printer connector



ISO 3274 (Cl.1)



122 x 60 x 62 mm (without probe)



USB



10°C to 40°C



-10°C to +50°C



650 g



Plastic transport case



Declaration of conformity

	06930013
	TESA RUGOSURF 20 portable surface roughness tester for use in the workshop Z = ± 200 µm (± 0.0079 in) X = 16 mm (0.63 in)
	Measuring span, µm 400 µm (0.0157 in) on Z axis, 16 mm (0.63 in) on X axis
	Indication span, µm Ra = 0 ÷ 100 µm; Rt = 0,05 ÷ 400 µm
	Accuracy class in accordance with ISO 3274 Class 1
	Measuring force, N 0,75 mN in accordance with ISO 3274
	Resolution, µm 0,001 µm
	Display LCD 2" black/white (160 x 100 pixels)
	Roughness parameters Ra, Rq, Rt, Rz, Rc, Rsm, Rmr, Pt, Pmr; Rmax; RPc, PPc; R, Rx, AR
	Graphics Bearing Area Curve (BAC), Amplitude Distribution Curve (ADC), Profile-R
	Cut-off length, mm 0,25 – 0,80 – 2,50 mm (0.010 – 0.030 – 0.100 in)
	Number of cut-off 1 to 5
	Stylus diamond tip (R = µm; angle °) R = 2 µm, 90°
	Memory capacity max 1000 measurements with parameters; max 20 measurements with profile and graphics
	Dimensions, mm 122 x 60 x 62 mm
	Degree of protection for keyboard (IP XX) IP67 (membrane keyboard)
	Digital data output (USB) USB cable connector to PC
	Weight, g 650 g
	Included in delivery RUGOSURF 20 SB10 standard skid probe Roughness standard Ra = 2,97 µm Positioning pin Ø 8 mm for use vertically Detachable probe protector Integral rechargeable battery Charger and adapter EU/US User manual Plastic carrying and storage case
	Measuring response time 1 to 10 s
	Probing speed, mm/s 1 mm/s (2 mm/s probe retract to measuring position)
	Units mm or inch
	Power supply 100 ÷ 240 VAC; 50 ÷ 60 Hz; 12 V, 400 ÷ 650 mAh



OPTIONAL ACCESSORIES:

04760099	Cable RUGOSURF 20 to PC
06960033	Printer for RUGOSURF + cables
06960034	RUGOSOFT Software + Dongle
06960035	Granite 400 x 250 mm with vertical support H150 mm, 25 kg, Grade 0 for Rugosurf 20 and 10G
06960081	Probe SB10 2µm for RUGOSURF 20 and 10G as SB10 but R = 2 µm
06960037	SB20 probe for RUGOSURF 20 et 10G for grooves of depth < 5 mm
06960038	SB30 probe for RUGOSURF 20 and 10G for small bores of Ø > 4 mm
06960039	SB40 Probe for RUGOSURF 20 and 10G V-shape for cylinders of Ø > 1 mm
06960040	SB50 probe for RUGOSURF 20 and 10G for concave surfaces and for measuring at 90° with RUGOSURF 10G
06960057	SB110 probe for RUGOSURF 20 and 10G for concave or convex surfaces, R > 5 mm
06960056	100 mm extension for probe with skid for RUGOSURF 20, 10G, 90G
06960064	Roughness standard Ra = 0,1 µm (4 µin)
06960065	Roughness standard Ra = 0,5 µm (20 µin)
06960066	Roughness standard Ra = 1,0 µm (40 µin)

STANDARD ACCESSORIES:

06960036	SB10 standard probe for RUGOSURF 20 and 10G R = 5 µm, 90°
06960041	Roughness standard Ra = 2,97 µm (117 µin)
06960045	Battery NiMH 7,2 V, 300 mAh, format PP3 for RUGOSURF 20 et 10G
057655	Vertical and adjustable positioning supports (2 parts) V-form for cylinder Ø > 100 mm for RUGOSURF 20
057941	Transport case with internal protection foam for RUGOSURF 20



- ISO 3274 (Cl. 1)
- 122 x 53 x 75 mm (without probe)
- USB
- 10°C to 40°C
- 10°C to +50°C
-
- 590 g
- Plastic transport case
- Declaration of conformity

TESA RUGOSURF 10G

Portable, versatile gauge unit with compact design, well suited for use in goods inwards inspection, production or the measurement laboratory.

3 horizontal measuring positions of probe 0°, -90° et +90°.

Measures roughness parameters according to standards:

- ISO 4287
- JIS B0601
- DIN and ISO 12085 (MOTIF or CNOMO).

TFT 2" graphic display for optimum visual representation of any measured parameters and workpiece profiles.

Direct displaying of all measured values and computed profiles.

31 roughness parameters available.

Flexible autonomy through mains adapter or battery pack.

Data storage, printing or transfer to a PC of a maximum of 999 measured results.

Possible tolerancing of all parameter values.

Multilingual menu options.

USB data output enabling a direct connection to a matrix printer unit or a PC equipped with RUGOSOFT 10 software (both are optional).

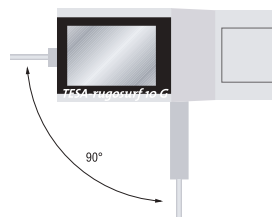

Probe measuring positions at -90°, 0°, +90°

Ra	0,088 µm
Rq	0,116 µm
Rt	0,889 µm
Rp	0,264 µm
05:00	Parameters

Measuring results

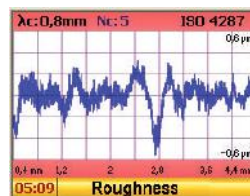

Profile measurement

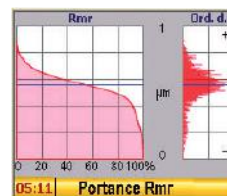

Bearing area curve (BAC) and amplitude distribution curve (ADC)



Measuring travel



	06930011
	TESA RUGOSURF 10G portable surface roughness tester for use in the workshop Z = ± 200 µm (± 0.0079 in) X = 16 mm (0.63 in) 3 probe measuring positions
	Measuring span, µm 400 µm (6300 µin) on Z axis, 16 mm (0.63 in) on X axis
	Display span, µm Ra = 0 ÷ 100 µm; Rt = 0,05 ÷ 400 µm
	Precision class in accordance with ISO 3274 Class 1
	Measuring force, N 0,75 mN (in accordance with ISO 3274)
	Resolution, µm 0,001 µm (0.1 µin)
	Display TFT 2" colour graphic screen
	Roughness parameters 31 parameters: Ra, Rq (Rms), Rt, Rz, Rp, Rc, Rv, Rsm, Rdc; Pa, Pq, Pt, Pp, Pc, Pv, Psm, Rdc; RPc, PPc; Rk, Rpk, Pvk, Mr1, Mr2; Pt, R, Rx, AR; R3, R3zm, Rmax;
	Graphics Bearing area curve, profil-R, profil-P
	Cut-off length, mm 0,25 – 0,80 – 2,50 mm (0.01 – 0.03 – 0.10 inch)
	Number of cut-off 1 to 10 for a cut-off of 0,25 and 0,8 mm
	Diamond point of stylus (R = µm; angle °) R = 5 µm, 90°
	Built-in memory Max. 1000 parameters; max. 20 measurements with parameters, profiles and graphics
	Dimensions, mm 122 x 53 x 81 mm
	Degree of protection of keyboard (IP XX) IP67
	Digital output (USB) USB cable connector to PC
	Weight, g 590 g
	Included in delivery Roughness standard Ra = 2,97 µm Built in rechargeable battery SB10 standard probe Battery charger EU and US Adaptor Positioning clamp for stand Ø 8 mm Vertical positioning stand User instructions
	Probing speed, mm/s 1 mm/s
	Units mm or inch
	Power supply 100 ÷ 240 VAC; 50 ÷ 60 Hz, 12 V, 400 ÷ 650 mA



OPTIONAL ACCESSORIES:

06960062	Cable RUGOSURF 10G and RUGOSURF 90G to PC (connector v3)
06960033	Printer for RUGOSURF + cables
06960034	RUGOSOFT Software + Dongle
06960035	Granite 400x250 mm with vertical support H 150 mm, 25 kg, Grade 0 for Rugosurf 20 and 10G
06960081	Probe SB10 2 μ m for RUGOSURF 20 and 10G as SB10 but R = 2 μ m
06960037	SB20 probe for RUGOSURF 20 et 10G for grooves of depth < 5 mm
06960038	SB30 probe for RUGOSURF 20 and 10G for small bores of $\varnothing > 4$ mm
06960039	SB40 Probe for RUGOSURF 20 and 10G V-shape for cylinders of $\varnothing > 1$ mm
06960040	SB50 probe for RUGOSURF 20 and 10G for concave surfaces and for measuring at 90° with RUGOSURF 10G
06960057	SB110 probe for RUGOSURF 20 and 10G for concave or convex surfaces, R > 5 mm
06960056	100 mm extension for probe with skid for RUGOSURF 20, 10G, 90G
06960064	Roughness standard Ra = 0,1 μ m (4 μ in)
06960065	Roughness standard Ra = 0,5 μ m (20 μ in)
06960066	Roughness standard Ra = 1,0 μ m (40 μ in)

STANDARD ACCESSORIES:

06960036	SB10 standard probe for RUGOSURF 20 and 10G R = 5 μ m, 90°
06960041	Roughness standard Ra = 2,97 μ m (117 μ in)
06960045	Battery NiMH 7,2 V, 300 mAh, format PP3 for RUGOSURF 20 et 10G
056631	Adjustable vertical positioning supports (2 parts) V-form for cylinder $\varnothing > 100$ mm for RUGOSURF 10G
06960047	Transport case with internal protection foam for RUGOSURF10-10G





Probe measuring position at 90° and adjustable in height

TESA RUGOSURF 90G

Small-size, versatile roughness gauge with tactile colour screen providing maximum ease of use. Ideally suited for high-precision measurements on the shop floor or in the inspection laboratory.

Special features of RUGOSURF 90G:

- Supplied with SB60/10 probe with removable pad: one single probe can be used to measure roughness or undulation!
- RUGOSURF 90G can measure a components with a height of up to 90mm, thanks to a vertical positioning screw without any additional accessory!
- With the PROFILE SET 2 mm (06960100) RUGOSURF 90G becomes a profile measurement instrument with a width of 2000 µm measuring in the Z axis (optional)!

Tactile TFT 3.5" colour screen.

Direct display of all measured values and computed profiles.

Measuring span

$$Z = 1000 \mu\text{m} (0.039 \text{ in})$$

$$X = \text{up to } 50 \text{ mm}$$



RUGOSURF 90G with tactile colour screen
Measurement with or without skid

Special 2 in 1 probe can measure with contact skid (roughness measurement) or without contact skid (measure of undulation).

Vertical adjusting screw for probe positioning up to a height of 90 mm without the need of an accessory.

Tolerancing of all parameters possible.

USB digital output for transfer of measured values to a PC with TESA MEASUREMENT STUDIO software (optional).

Unique in its category, this instrument can also do profile measurement (Z = 2 mm) if used with PROFILE SET 2 mm (optional).

Measures roughness parameters according to standards:

- ISO 4287
- 12085 (CNOMO)
- ISO 13565
- DIN 4776
- JIS B0601:2001
- ASME B46-2002

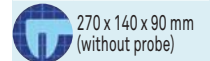
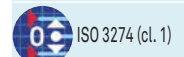

Roughness profile



Roughness parameters

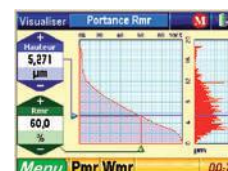

Bearing area curve (BAC) and amplitude distribution curve (ADC)

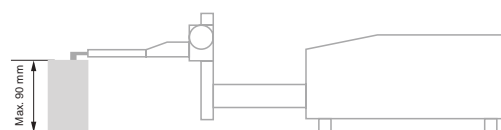

Fine adjustment of vertical position up to 90 mm

	06930012	
		TESA RUGOSURF 90G portable table roughness tester Z = ± 500 µm (± 0.0197 in) X = 50 mm (1.968 in) probe with detachable skid
	Measuring span, µm	Z Axis = 1000 µm (39370 µin); X Axis = 50 mm (1.969 in)
	Indication span, µm	Ra = 0 ÷ 400 µm; Rt = 0 ÷ 1000 µm
	Precision class	In accordance with ISO 3274 Class 1
	Measuring force, N	0,75 mN according to ISO 3274
	Resolution, µm	0,001 µm (0.01 µin)
	Display	Tactile graphic colour screen TFT 3.5" (320 x 240 pixels)
	Roughness parameters	48 parameters: Ra, Rq, Rt, Rz, Rp, Rc, Rv, Rsm, Rdc, R _{Pc} , Pa, Pq, Pt, Pp, Pc, Pv, Psm, R _{Pc} , P _{Pc} , Wa, Wq, Wt, Wz, Wp, Wv, Wc, WSm, Wdc, W _{Pc} , Rk, Rpk, Pvk, Mr1, Mr2, Pt, R, Rx, AR, Wte, W, AW, Wx, Rke, R _{pke} , R _{vke} , Rmax, R3z, R3zm
	Graphics	Profil-W, Profil-R, Profil-P, Bearing area curve
	Cut-off length, mm	0,08 – 0,25 – 0,80 – 2,50 – 8,00 mm
	Number of cut-off	1 to 19 for cut off up to 2,5 mm; 1 to 5 for cut off of 8,00 mm
	Diamond or stylus tip (R = µm; angle °)	R = 5 µm, 90°
	Memory capacity	Max. 60'000 measurements with parameters
	Dimensions (mm)	270 x 140 x 90 mm
	Degree of protection of keyboard (IP XX)	IP67 (membrane keyboard)
	Digital output (USB)	USB cable connector to PC
	Weight, kg	3 kg
	Included in delivery	<ul style="list-style-type: none"> – RUGOSURF 90G – Roughness standard Ra = 2,97 µm – Standard probe SB60/10 with or without skid – Probe holder – Guiding column, vertical setting range 90 mm – Integrated rechargeable battery, 12 V – Charger for battery
	Measuring response time	–
	Probing speed, mm/s	0,5 mm/s or 1,0 mm/s selection options
	Units	mm or inch
	Power supply	100 ÷ 240 VAC / 50 ÷ 60 Hz; 18 V, 2,2 Ah



OPTIONAL ACCESSORIES:

06960062	Cable RUGOSURF 10G and RUGOSURF 90G to PC (connector v3)
06960033	Printer for RUGOSURF + cables
06960048	MEASUREMENT STUDIO software + dongle for RUGOSURF 90G
06960055	Granite 630 x 400 mm with vertical support H250mm, 60 kg, Grade 0 for RUGOSURF 90G
06960064	Roughness standard Ra = 0,1 µm (4 µin)
06960065	Roughness standard Ra = 0,5 µm (20 µin)
06960066	Roughness standard Ra = 1,0 µm (40 µin)
06960100	PROFILE SET 2 mm for profile measurement with RUGOSURF 90G
06960056	100 mm extension for probe with skid for RUGOSURF 20, 10G, 90G
06960067	SB60/10 2µm probe for RUGOSURF 90G as SB60/10 but R = 2 µm
06960050	SB20P probe for RUGOSURF 90G for grooves of depth < 5 mm
06960051	SB30P probe for RUGOSURF 90G for small bores with Ø > 4 mm
06960052	SB40P probe for RUGOSURF 90G V-shape for cylinders with Ø > 1 mm
06960053	SB50P probe for RUGOSURF 90G for concave surfaces and for measuring at 90° with RUGOSURF 90G
06960054	SB120P probe for RUGOSURF 90G for grooves of depth < 20 mm
06960058	SB120S probe without skid for RUGOSURF 90G for grooves of depth < 15 mm
06960061	SB60-D2-L30 probe, L = 30 mm for RUGOSURF 90G for small bores of Ø > 2 mm

STANDARD ACCESSORIES:

06960049	SB60/10 standard probe for RUGOSURF 90G R = 5 µm, 90° detachable skid
06960041	Roughness standard Ra = 2,97 µm (117 µin)
056645	Transport case with internal protective foam for RUGOSURF 90G





Roughness parameters according to: ISO 4287, ISO 13565-1, ISO 13565-2, ISO 12085, VDA 2007



Z = 2 mm
X = 50 mm



Z = 0,1 µm
X = 0,4 to 4,0 µm according to the length being measured



Z = 3,5 + 0,75*H microns, (H in the Z axis, in mm) X = 3,5 + L/10 microns (L in the X axis, in mm)



0,3 mg (0,003 mN) with the SB2000 probe



1 mm/s



Maximum angle of 70° (upward position); maximum angle of 85° (downward position)

TESA PROFILE SET 2 mm

PROFILE SET 2 mm for profile measurement (compatible with RUGOSURF 90G).

When equipped with the SB2000 probe and used with the PROFILE STUDIO software dedicated for profile measurement STUDIO PROFILE, the RUGOSURF 90G roughness gauge converts into a profile-measuring tool.

A simple, ingenious and accurate solution, this optional accessory measures lengths, radii and angles of parts which are sometimes impossible to verify by other means.

The setting up and the evaluation of measurements is simple and fast. Dimensions can be inserted into the measured profile after defining geometric elements (point, line, arc or intersection between two lines, for example). The tolerance values allow verification of the results at a glance. Rotation and symmetry of the profile also allows its orientation.

A previous measurement can be used as model for the repeated measurement of a part of identical geometry. This saves valuable time and facilitates operations as important manual measurements can be replicated automatically.

A standard profile with a measurement report is included in the PROFILE SET 2 mm set.

A detailed measurement report with customizable header can be generated from the PROFILE STUDIO software.

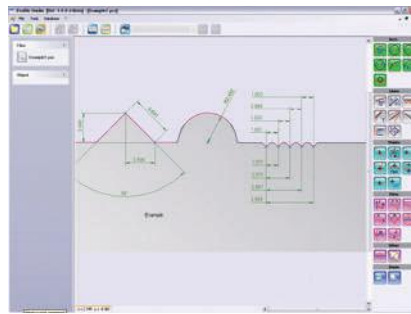

PROFILE STUDIO software

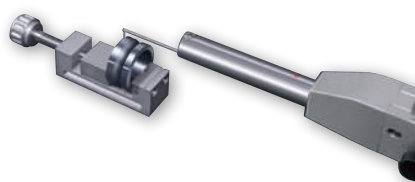
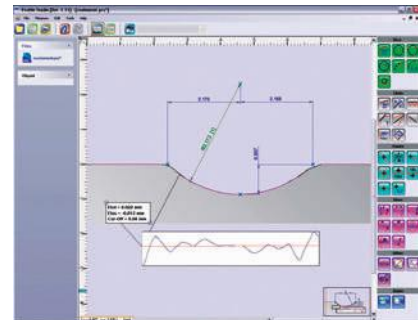

SB2000 probe

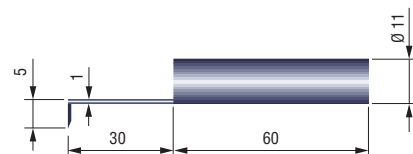

No

=

06960100 PROFILE SET 2 mm for profile measurement with RUGOSURF 90G

DELIVERED WITH THE FOLLOWING ACCESSORIES:

06960101 PROFILE STUDIO Software

06960102 SB2000 probe for PROFILE SET 2 mm, R = 15 µm, 20°

06960103 Setting master for PROFILE SET 2 mm

06960062 Cable RUGOSURF 10G and RUGOSURF 90G to PC (connector v3)



RUGOSOFT Software

Software for RUGOSURF 20 and RUGOSURF 10G.

Enables the user to import stored measurement values from the device to the computer for the management of a database.

Optimal and detailed visualization of the results: parameters, profiles (R roughness and P primary profile) or a combination of both.

Calculation of roughness parameters.

Statistical analysis of a set of measurements.

Creation and storage of measuring programs (instrument parameters and parameters to be measured) in the software, which can then be loaded onto the instrument.

Customizable measurement report.

Output from the PC

- measuring results with measuring parameters
- profiles as coordinates
- measuring report in format: .xls .pdf .doc .rpt (Crystal Report) or also .rtf (Rich Text Format)

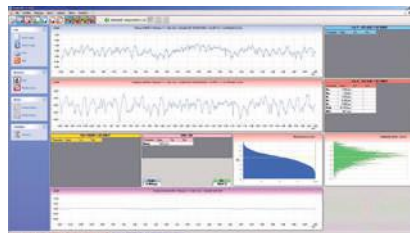

RUGOSOFT

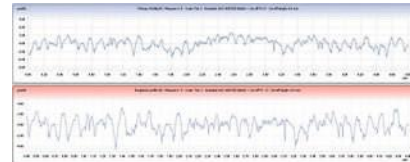

Roughness profile and primary profile



Statistics



Parameters and bearing area curve

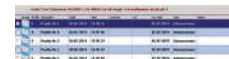

List of measurements



Included in delivery

06960034	RUGOSOFT Software + Dongle	<ul style="list-style-type: none"> - USB protection key (dongle) - Installation CD - User instructions plus online support (included in the installation CD)
-----------------	----------------------------	---

OPTIONAL ACCESSORIES:

04760099	Cable RUGOSURF 20 to PC
06960062	Cable RUGOSURF 10G and RUGOSURF 90G to PC (connector v3)



MEASUREMENT STUDIO Software

Software for RUGOSURF 90G.

Enables the import of stored measurement data from the device to the computer, for processing in a database.

Optimal and detailed visualization of the results: parameters, profiles (W undulation, P primary profile and R roughness) or the three.

Calculation of roughness parameters including VDA parameters.

Statistical analysis of a set of measurements.

Creation and storage of measuring programs in the software, which can then be loaded onto the instrument.

Customizable measurement report.

Output from the computer

- measuring results with measuring parameters
- profiles as coordinates
- measuring report in format .xls .pdf .doc .rpt (Crystal Report) or .rft (Rich Text Format)



MEASUREMENT STUDIO

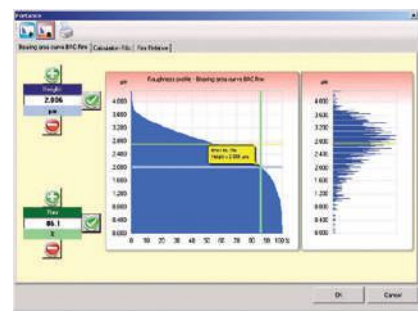

Bearing area curve

Parameter	Measurements	Average	Min	Max	Range	St
Pa	3	2.521	0.828	12.114	10.986	2.983
Pp	3	2.341	0.942	11.517	10.575	2.368
Ra	3	0.995	0.294	11.164	10.870	3.521
Rp	3	2.905	1.137	4.126	2.989	1.262
Rq	3	0.186	0.288	4.681	4.393	2.022
Rz	3	8.182	3.462	11.817	7.955	3.253
Rv	3	4.021	1.263	10.276	9.013	3.963
RSm	3	0	0	0	0	0
RSt	3	0.996	4.214	11.964	7.628	3.327
RStp	3	0	0	0	0	0
Pa	3	2.179	0.526	3.216	2.690	1.100
Pp	3	2.883	0.676	3.862	3.187	1.200
Ra	3	0.597	0.408	10.392	9.984	3.629
Rq	3	0.095	0.176	0.524	0.348	0.471
Rz	3	8.192	3.750	11.225	7.475	2.175
Rv	3	7.635	1.797	10.506	8.709	3.734
RSm	3	0	0	0	0	0
RSt	3	0.197	0.405	10.262	9.857	3.659
PPa	3	0	0	0	0	0
Ra	1	0.336	0.336	0.336	0.000	0.000
Rq	1	0.085	0.085	0.085	0.000	0.000
Rz	1	0.975	0.975	0.975	0.000	0.000
Rv	1	0.300	0.300	0.300	0.000	0.000
Rk1	1	0.938	0.938	0.938	0.000	0.000
Rk2	1	0.300	0.300	0.300	0.000	0.000
Rmax	0	16.301	8.216	12.829	8.373	2.769
Rmin	3	2.361	2.407	10.402	7.995	7.547
R10m	3	1.881	2.794	11.200	8.406	3.672
Wd1m	0	0.000	0.000	0.000	0.000	0.000
Wd1c	0	0.000	0.000	0.000	0.000	0.000
Wd1r	0	0.000	0.000	0.000	0.000	0.000

Statistics

Paw VDA 2007			
Parameter	Value	Tol-	Tol+
wD5m	0.273 µm		
wDc	0.571 µm		
wDt	2.243 µm		

VDA parameters

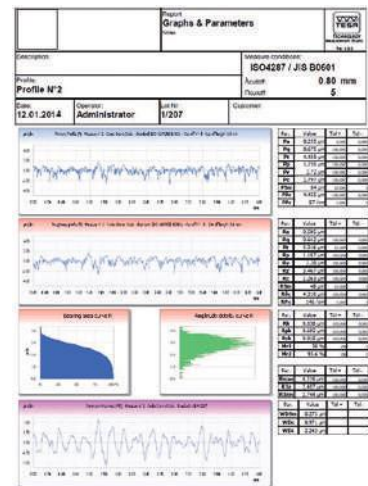

Measuring report with customisable header and logo



06960048 MEASUREMENT STUDIO software + dongle for RUGOSURF 90G

Included in delivery

- USB protection key (dongle)
- Installation CD, 6 languages
- User instructions (included on the installation CD)
- USB connection cable to the PC for RUGOSURF 10G and RUGOSURF 90G, length 1,80 m



PROFILE STUDIO Software

For profile measurement using the RUGOSURF 90G.

Allows evaluation of micro and macro geometric characteristics of a surface.

Measurement programme creation that can be saved for the same measurements on a batch of identical parts from the same set or for subsequent batch measurements: it is possible to use all the dimensions and tolerances of a reference profile for a measurement of a batch of the same part.

Measurement instructions and help assistance for calibration controlled from the PC.

Import and export of measurement parameters from and to the device.

Storage of measurement results and of the measured parameters as database.

Database search with filters (date, operator, batch, etc.).

Detailed visualization of the measured profile and geometric construction tools (arc, line, point, intersection, angle, etc.).

Measurements reports with customizable header.

Languages: English, German, French, Spanish, Italian, Portuguese, Slovenian.

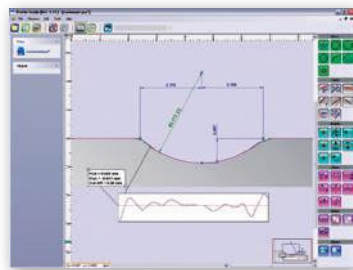

PROFILE STUDIO software

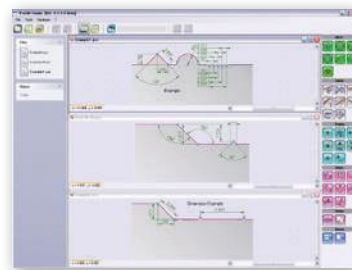

Measurement of geometric elements



No

=



Included in delivery

06960101

PROFILE STUDIO Software

CD with PROFILE STUDIO software

OPTIONAL ACCESSORIES:

06960102

SB2000 probe for PROFILE SET 2 mm, R = 15 µm, 20°

06960103

Setting master for PROFILE SET 2 mm

06960062

Cable RUGOSURF 10G and RUGOSURF 90G to PC (connector v3)

PROBES FOR TESA RUGOSURF

Standard probes for TESA RUGOSURF roughness gauges, available with different geometries and sizes according to the nature and type of surface being measured.

Standard Probes

Standard probes supplied with TESA surface roughness gauges and SB2000 probes for profile measurement

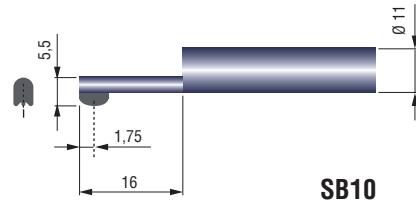

SB10

SB10 probe

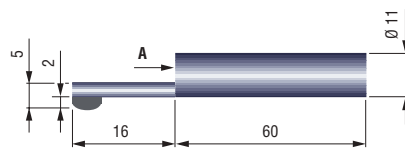

SB60/10 probe with removable skid for RUGOSURF 90G

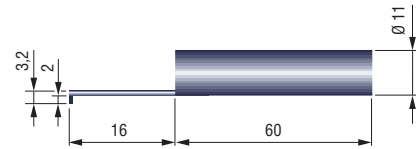

SB2000 probe without skid

No	=
06960036	SB10 standard probe for RUGOSURF 20 and 10G R = 5 µm, 90°
06960049	SB60/10 standard probe fur RUGOSURF 90G R = 5 µm, 90° detachable skid

Unless otherwise stated, 90° diamond tip, radius R = 5 µm



Optional Probes for RUGOSURF 20 and 10G

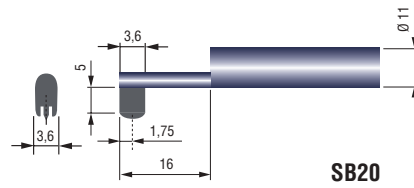

SB20

06960037

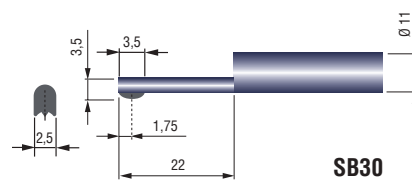

SB30

06960038

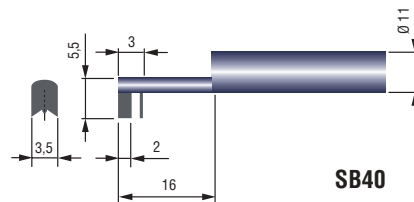

SB40

06960039

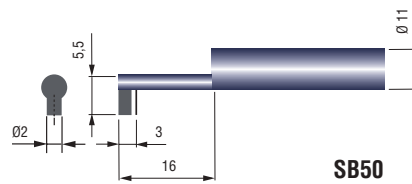

SB50

06960040

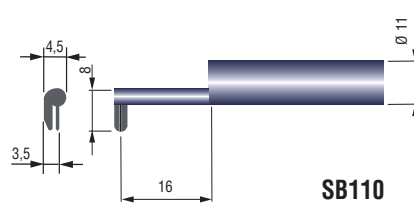

SB110

06960057

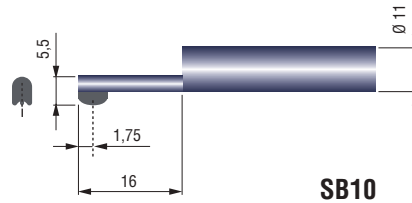

SB10

06960081 SB10 but R = 2 µm

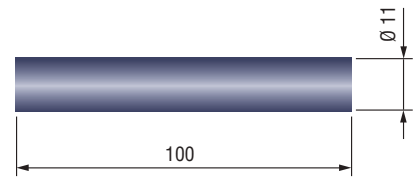

06960056

No	≡
06960037	SB20 probe for RUGOSURF 20 et 10G for grooves of depth < 5 mm
06960038	SB30 probe for RUGOSURF 20 and 10G for small bores of $\varnothing > 4$ mm
06960039	SB40 Probe for RUGOSURF 20 and 10G V-shape for cylinders of $\varnothing > 1$ mm
06960040	SB50 probe for RUGOSURF 20 and 10G for concave surfaces and for measuring at 90° with RUGOSURF 10G
06960057	SB110 probe for RUGOSURF 20 and 10G for concave or convex surfaces, R > 5 mm
06960081	Probe SB10 2µm for RUGOSURF 20 and 10G as SB10 but R = 2 µm
06960056	100 mm extension for probe with skid for RUGOSURF 20, 10G, 90G

Unless otherwise stated, 90° diamond tip, radius R = 5 µm



Optional Probes for RUGOSURF 90

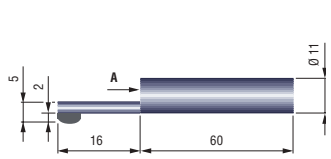

06960067

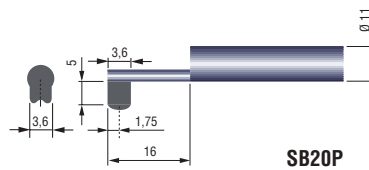

06960050

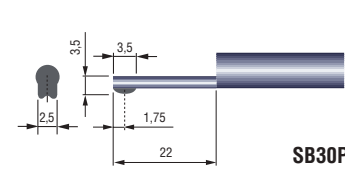

06960051

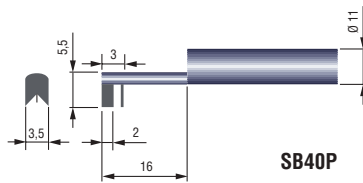

06960052

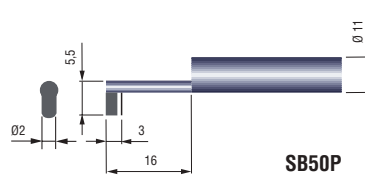

06960053

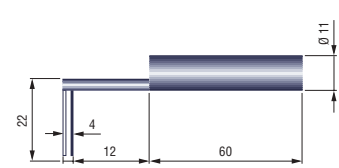

06960054

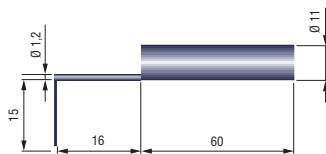

06960058

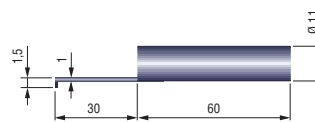

06960061

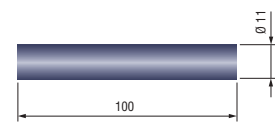

06960056



06960067	SB60/10 2µm probe for RUGOSURF 90G as SB60/10 but R = 2 µm
06960050	SB20P probe for RUGOSURF 90G for grooves of depth < 5 mm
06960051	SB30P probe for RUGOSURF 90G for small bores with $\varnothing > 4$ mm
06960052	SB40P probe for RUGOSURF 90G V-shape for cylinders with $\varnothing > 1$ mm
06960053	SB50P probe for RUGOSURF 90G for concave surfaces and for measuring at 90° with RUGOSURF 90G
06960054	SB120P probe for RUGOSURF 90G for grooves of depth < 20 mm
06960058	SB120S probe without skid for RUGOSURF 90G for grooves of depth < 15 mm
06960061	SB60-D2-L30 probe, L = 30 mm for RUGOSURF 90G for small bores of $\varnothing > 2$ mm
06960056	100 mm extension for probe with skid for RUGOSURF 20, 10G, 90G

Unless otherwise stated, 90° diamond tip, R = 5 µm



DOT MATRIX PRINTER FOR RUGOSURF

Dot matrix printer for TESA RUGOSURF portable roughness gauges and with built-in batteries, which enable the printing of measured parameters and roughness profiles regardless of the environment and the conditions.

It is also possible to print stored measurements data from the instrument memory.

PR Dot Matrix Printer

Dot matrix printer for TESA RUGOSOFT roughness gauges.

For printing measured parameters, and roughness profiles.

Also for printing measurement data saved in the instrument memory.



PR dot matrix portable printer for RUGOSURF

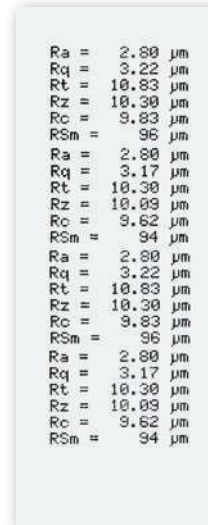

Roughness parameters measured



Measuring results and graphics with header

Roughness profile

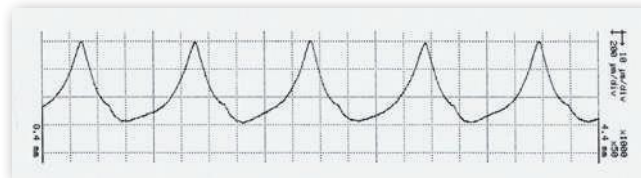

No	=	Characteristics	Dimensions L x W x H, mm	Weight, g	Included in delivery
06960033	Printer for RUGOSURF + cables	Print-out of measured parameters	165 x 120 x H100 mm (6.50 x 4.72 x H3.94 in)	760 g (only printer)	<ul style="list-style-type: none"> - Printer - Cables for connection to the RUGOSURF - Ink ribbon - Roll of paper - Rechargeable battery - User instructions - Transport case

DELIVERED WITH THE FOLLOWING ACCESSORIES:

- 056109 Connecting cable RUGOSURF 10G and RUGOSURF 90G to dot matrix printer
- 058213 Connecting cable RUGOSURF 20 to dot matrix printer



Accessories for PR Dot Matrix Printer

Ink ribbon for printer

Paper roll

Battery

Transport case



06960044



06960043	Set of 3x ink ribbons for dot matrix printer
06960044	Set of 10 paper rolls size 57 mm for dot matrix printer
056133	Power supply 100 ÷ 240 V, 50 ÷ 60 Hz, 0,5 Ah, Output 9 V DC, max. 18 W, 5,5 mm connector with EU and US adapter, for PR dot matrix printer
056223	Transport case with foam for internal protection of PR dot matrix printer



ACCESSORIES FOR TESA RUGOSURF, PROFILE SET 2 MM

Accessories for TESA RUGOSURF surface roughness testers, including Ra roughness specimens, granite bases with measuring supports, vertical supports for positioning, etc.

Other Accessories for RUGOSURF

External control for RUGOSURF 10G or 90G

Fixing pin Ø 8mm for universal support for RUGOSURF 20 ou 10G

Vertical positioning supports for RUGOSURF 20 or 10G

Probe holder for RUGOSURF 90G



06960042

No	=
056631	Adjustable vertical positioning supports (2 parts) V-form for cylinder Ø > 100 mm for RUGOSURF 10G
057655	Vertical and adjustable positioning supports (2 parts) V-form for cylinder Ø > 100 mm for RUGOSURF 20
056633	Fixing pin Ø 8 mm for universal support for RUGOSURF 20 and 10G
056641	Probe holder with two positions – blocked position for measuring with a probe without skid – free position for measuring with a probe with skid for RUGOSURF 90G
06960042	External control for RUGOSURF 10G and 90G
06960059	External control with PR dot matrix printer cable for RUGOSURF 10G and 90G

Chargers and Rechargeable Batteries



06960045

No	=
06960045	Battery NiMH 7,2 V, 300 mAh, format PP3, for RUGOSURF 20 et 10G
056224	Battery NiMH 12 V, 1800 mAh, for RUGOSURF 90G
06960046	Charger and power supply 100 ÷ 240 VAC, 50 ÷ 60 Hz, 12 V, 400 ÷ 600 mAh with EU and US adapter for RUGOSURF 20 and 10G
056639	Charger and power supply 100 ÷ 240 VAC, 50 ÷ 60 Hz, 18 V, 2,2 Ah with EU and US adapter for RUGOSURF 90G



Granite Bases with Measuring Support for RUGOSURF

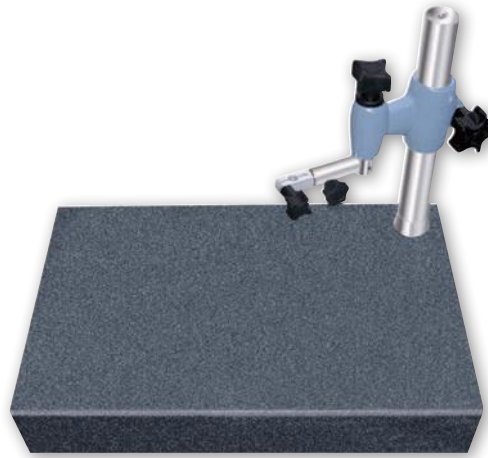

Granite base with measuring support for RUGOSURF 20 or 10G



Granite base with measuring support for RUGOSURF 90G with manual vertical positioning device



06960035

Granite 400 x 250 mm with vertical support H 150 mm,
25 kg, Grade 0 f
or Rugosurf 20 and 10G

06960055

Granite 630 x 400 mm with measuring support and manual vertical
positioning device H250mm, 60 kg, Grade 0
for RUGOSURF 90G



Ra Roughness Standards

As per EN ISO 5436-1 standard



Standard Ra = 2,97 μm

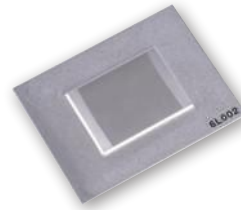

Standard Ra = 1,00 μm



Standard Ra = 0,50 μm



Standard Ra = 0,10 μm

No	=
06960041	Roughness standard Ra = 2,97 μm (117 μin)
06960066	Roughness standard Ra = 1,0 μm (40 μin)
06960065	Roughness standard Ra = 0,5 μm (20 μin)
06960064	Roughness standard Ra = 0,1 μm (4 μin)

Setting Standard for PROFILE SET

For profile measurement

No	=
06960103	Setting master for PROFILE SET 2 mm



RUGOTEST Roughness Comparison Specimens

For tactile and visual comparison of the workpiece surface finish according to various machining processes.

The specimen sets are according to individual machining processes.

ISO 2632-1 and 2632-2



ISO 2632
Parts 1 and 2

Rust-resistant
nickel

Specimens for
roughness com-
parison cannot be
used as reference
ones. Therefore, they
are not suitable for
calibrating surface
roughness testers.

Leather case

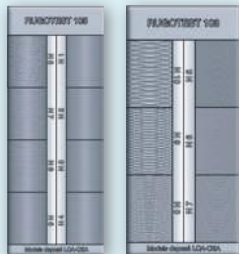

No	=	RUGOTEST N°	Number of samples	ISO roughness parameters	Dimensions, mm	g	Included in delivery
081112053		RUGOTEST 1	1	M1 - N10	135 x 105	160	Side milling (3 specimens), N8-N9-N10; Face milling (5 specimens), N6-N7-N8-N9-N10; Turning/Planing (5 specimens), N6-N7-N8-N9-N10; Grinding (6 specimens), N2-N3-N4-N5-N6-N7; Lapping (4 specimens), N2-N3-N4-N5; Finish grinding / honing (4 specimens), N1-N2-N3-N4
081112054		RUGOTEST 2	2	N6 - N11	120 x 90	160	
081112055		RUGOTEST 3	3	N6 - N11	120 x 90	190	With samples for shot blasting, spherical coarse grains (3 specimens), N9-N10-N11; With samples for shot blasting, spherical fine grains (6 specimens), N6-N7-N8-N9-N10-N11; With samples for shot blasting, angular coarse grains (3 specimens), N9-N10-N11; With samples for shot blasting, angular fine grains (6 specimens), N6-N7-N8-N9-N10-N11
081112056		RUGOTEST 4	4	N6 - N8	120 x 90	160	Straight filing (3 specimens), N6-N7-N8; Cross filing (3 specimens), N6-N7-N8
081112057		RUGOTEST 5	5	N0 - N4	120 x 90	200	Surface cylindrical form (5 specimens), N0-N1-N2-N3-N4; Surface flat form (5 specimens), N0-N1-N2-N3-N4;
081112058		RUGOTEST 101 Sanding	101	N6 - N11	110 x 50	110	
081112059		RUGOTEST 102 Turning	102	N5 - N10	110 x 50	105	
081112060		RUGOTEST 103 Face milling	103	N5 - N10	110 x 50	110	
081112061		RUGOTEST 104 Circular grinding	104	N1 - N8	130 x 50	125	
081112062		RUGOTEST 105 Spark erosion	105	N1 - N8	130 x 50	130	
081112063		RUGOTEST 107 Charmilles	107	N5 - N10	110 x 50	110	
081112344		RUGOTEST Spark erosion	12	12 to 45	127 x 27	60	
081112346		RUGOTEST A4 Set of 4 sets of surface specimens with RUGOTEST 1, 2, 3 and 4			330 x 250	710	
081112345		RUGOTEST A6 Set of 6 sets of surface specimens with RUGOTEST 101, 102, 103, 104, 105, 107			330 x 250	780	



ISO Roughness Parameters	Roughness Ra μm (μin)	Charmilles Roughness Parameters (VDI 3400)	Roughness Ra μm
N0	0,0125 (0.5)	12	0,40
N1	0,025 (1)	15	0,56
N2	0,05 (2)	18	0,80
N3	0,1 (4)	21	1,12
N4	0,2 (8)	24	1,60
N5	0,4 (16)	27	2,24
N6	0,8 (32)	30	3,15
N7	1,6 (63)	33	4,5
N8	3,2 (125)	36	6,3
N9	6,3 (250)	39	9,0
N10	12,5 (500)	42	12,5
N11	25,0 (1000)	45	18,0



ISO 2632 Parts 1 and 2



Rust-resistant nickel



The comparison specimens are not roughness standards. They should not be used for the calibration of surface roughness instruments



Leather case



Height Gauges



INSPECTION DURING THE COURSE OF THE MANUFACTURING PROCESS

Height gauges are single-axis handtools made to measure on a surface plate, preferably on granite. The TESA- μ HITE version being offered in this section clearly shows that combining a surface plate with any height gauge can create a complete measuring system.

Providing the necessary versatility, they are well suited for dimensional inspection directly on a machine or a group of machines, usually during the various setting and sampling operations throughout the whole manufacturing process.

They are specially made for checking parts that are difficult to machine due to their critical sizes.

TESA-HITE or TESA MICRO-HITE, whether manually operated or motor-driven, do not require any special skills. Nearly everyone working in the workshop can use them easily.



SCS Calibration Certificate

The newly implemented TESA-HITE and TESA MICRO-HITE production line now also includes its own temperature-controlled laboratory recently certified by the Swiss Accreditation Service (SCS), so that each height gauge comes with a SCS calibration certificate provided free of charge.

The negligible temperature variation ($20^{\circ}\text{C} \pm 0,1^{\circ}$) along with the use of high-precision step gauges allow the lowest uncertainty of measurement to be achieved during the calibration process.

As a first step, all values needed for automatic compensation for the systematic errors of the finished height gauge through Computer Aided Accuracy (CAA) are captured.

Once conveniently calculated, each single compensation value is then stored in the tool memory so as to allow the automatic calculation of the measured values during calibration.





Finally, the relevant calibration certificate is issued based on the values obtained during a new series of measurements taken at another measuring station, also equipped with step gauges. The applied calibration procedure together with the SCS based certification ensure that every TESA height gauge is traceable to national standards.

Height Gauges – One of TESA's Strengths

TESA offers the largest range of height gauges for reliable one or two-dimensional measurements. End users can choose the most suitable model not only according to the requirements of their metrology applications, but also according to their financial resources.

This wide range goes from the simple height and scribing gauge to the motorised vertical column suitable for high-precision measurements in two coordinate directions.



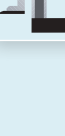













				1D				2D		Motorized
Height Gauges	µm (L in m)	Standard Accessory (mm)	Special Accessory (mm)							
 TESA-HITE Magna	8	870	1095	•	•					
 TESA-HITE	2,5 + 4L	870	1095	•	•	•				
 TESA-HITE plus M	2,5 + 3L	860	1085	•	•	•	•	•	•	•
 TESA MICRO-HITE	2 + 3L	1075	1300	•	•	•	•	•		
 TESA MICRO-HITE plus M	1,9 + 1,5L	1075	1300	•	•	•	•	•	•	•
 TESA-µHITE	1 or 2	160	360	•	•					•
 TESA-µHITE + POWER PANEL plus M	1 or 2	160	360	•	•		•	•	•	•
 ETALON height and scribing gauges	40	1000	-	•						



TESA-HITE Magna 400 and 700

Conceived using well-proven TESA technology, both the TESA-HITE magna 400 and 700 models are equipped with the TESA patented magna μ measuring system and can be used in the harshest workshop conditions, especially where the gauges are exposed to splashing liquids of any kind and the penetration of dust particles. Their unique characteristics means that the gauges offer the most favourable price/performance ratio found in the market and constitute an essential tool in the workshop. Robust and reliable, their futuristic design guarantees maximum strength when used near production machines. Each height gauge is provided with a rechargeable battery and can be used to measure height or step dimensions as well as diameters, centre to centre distance of bores or grooves, the size of grooves and much more.

- Wide application range, two sizes available with measuring span to 415 mm/ 16 in or 715 mm/28 in, respectively.
- Electronics totally protected against oil and water splashing or dust particles (IP65).
- Control panel with numerical display to 0,001 / 0,005/0,01 mm or 0,0001/0.0002/ 0.001 in.
- Dynamic probing of the workpiece with a constant measuring force.
- Easiness, high reliability when checking bores or shafts using TESA's unique device for automatic detection of the culmination point – patented.
- Acoustic signal to acknowledge value capture, also conveniently program-mable.
- Ability to measure parallelism errors.
- TESA's magnetic system, guaranteeing correct operating even in harsh workshop conditions – patented.
- Large LC display, also with symbols for the measuring functions.
- Zero-setting anywhere within the measuring range.
- PRESET function for entering any given value.
- Metric/inch conversion.
- RS 232 data output.
- SCS calibration certificate provided with each height gauge.

-  Factory standard
-  83 x 49 mm LC display, 7-decade plus minus sign. Also with graphical symbols for all active functions.
-  0,001 / 0,005 / 0,01 mm or 0,0001 / 0.0002 / 0.001 in
-  12 mm
-  Magnetic scale
-  Metric/Inch conversion
-  Nickel plated gauge base (chemical coating)
-  1,5 ± 0,5 N (at switch point)
-  500 mm/s 20 in/s
-  Measuring span, application range and precision: see relevant table on page N-5.
-  Probing head mounted on a ball-bearing, hand wheel for head displacement, fine setting. Head drive carriage can be locked.
-  RS232
-  Rechargeable batteries, 6V
-  ~ 60 h



- $(12 \pm 1,5) \times 10^{-6} K^{-1}$
- $-10^{\circ}C$ to $40^{\circ}C$
- $-10^{\circ}C$ to $60^{\circ}C$
- 100 %
- IP55 or IP65 for both electronics and measuring system (IEC 60529)
- EN 61326, Class B (with disconnected charger)
- See table
- Shipping packaging
- Identification number
- Declaration of conformity
- SCS calibration certificate

No	=		
		mm	in
00730047	Height gauge TESA-HITE magna 400	415	16
00730059	Height gauge TESA-HITE magna 700	715	28
CONSISTING OF:		400	700
00760143	Standard probe insert holder	●	●
00760157	Rechargeable battery, 6V	●	●
00760164	Standard probe insert with 5mm dia. tungsten carbide ball tip	●	●
00760231	Master piece for establishing the probe constant, nominal dimension 6,350 mm / 0.250 in	●	●
04761054	Mains adapter 100 ÷ 200 VAC / 50 ÷ 60 Hz	●	●
04761055	Cable EU for mains adapter	●	●
04761056	Cable US for mains adapter	●	●
OPTIONAL ACCESSORIES:			
04761052	Extension cable, Sub-D 9p/f to 9p/m, 2 m		
04761063	Sub-D 9p/m to USB cable, 2 m		

Technical Data

Models	TESA-HITE magna		
	400	700	
	mm	415	715
	in	16	28
With standard accessory	mm	0 ÷ 570	0 ÷ 870
	in	0 ÷ 22	0 ÷ 34
With probe insert holder No. 00760057	mm	0 ÷ 625	0 ÷ 925
	in	0 ÷ 24	0 ÷ 36
With probe insert holder No. S07001622	mm	0 ÷ 795	0 ÷ 1095
	in	0 ÷ 31	0 ÷ 43
With standard accessory	µm	< 8	< 8
	in	< 0.0003	< 0.0003
With standard accessory	On flat surfaces:		
	$2\sigma < 3\mu m / < 0.00015$ in		
	Into bores:		
	kg	15	18

Standard Accessories

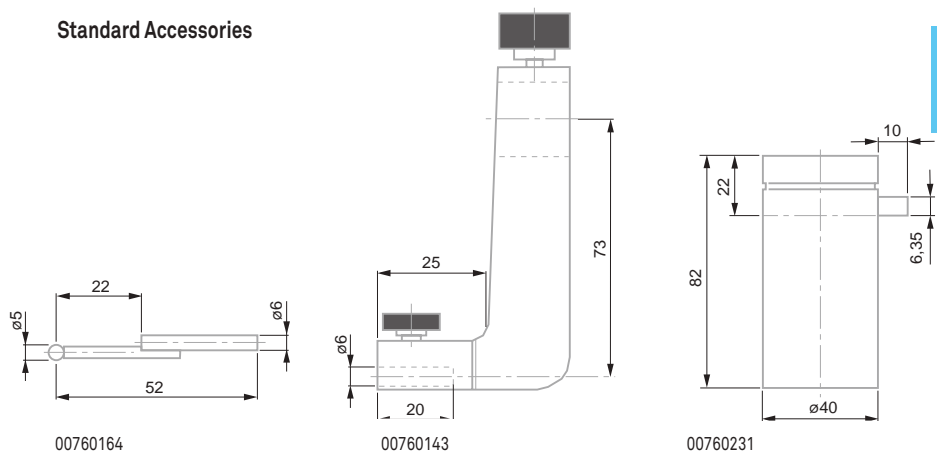

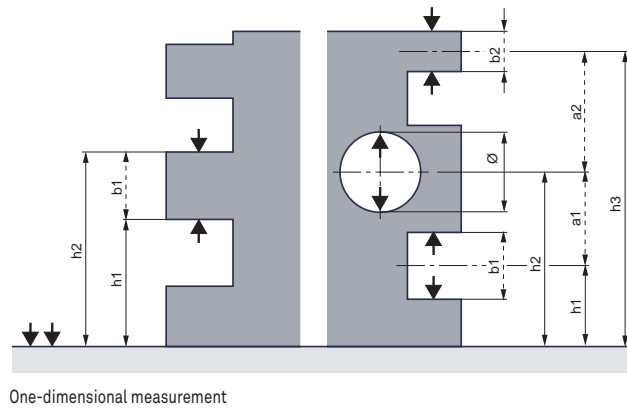
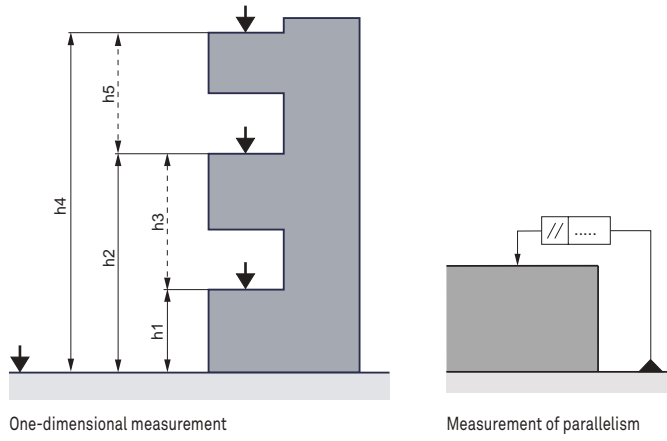

One-dimensional measurement





N Factory standard



83 x 49 mm LC display. 7-decade plus minus sign. Also with graphical symbols for all active functions.



0,0001 / 0,001 / 0,01 mm or 0,00001 / 0,0001 / 0,001 in



12 mm



Incremental glass scale, opto-electronic



mm/in conversion



Frontal, model 400 <math>< 9 \mu\text{m}</math>, model 700 <math>< 13 \mu\text{m}</math>



Nickel plated gauge base (chemical coating) with bottom face including 3 resting points, finely lapped.



1,5 ± 0,5 N (at switch point)



500 mm/s 20 in/s



Air-cushion for easy displacement over the surface plate. Measuring span, application range and precision: see table on page N-8.



Probing head mounted on a ball-bearing, hand wheel for head displacement, fine setting. Head drive carriage can be locked.



RS232



Rechargeable batteries, 6V



≈ 60 h

TESA-HITE 400 / 700

By their robustness and reliability, the TESA-HITE 400 and 700 provided with its optoelectronic incremental rule (TESA patented) measurement system are ideally suited for applications in the workshop.

Their battery power gives them full autonomy.

Each version allows, among other things, the entry height dimensions or staged, the diameter, the distance between two grooves or two holes and groove width.

- Integrated air-bearing for easy displacement across the granite plate.
- Electronics totally protected against oil and water splashing, dust particles (IP65).
- Control panel with numerical display to 0,0001 / 0,001 / 0,01 mm or 0.00001 / 0.0001 / 0.001 in.
- Dynamic probing of the workpiece with a constant measuring force.
- Easiness, high reliability when checking bores or shafts using TESA's unique device for automatic detection of the culmination point – patented.
- Acoustic signal to acknowledge value capture, also conveniently programmable.
- Ability to measure any deviation in parallelism.
- Possible use of a digital sensor for determining perpendicularity errors with stated angle of the linear regression line.
- Patented TESA's opto-electronic system. Long-lasting stability of the glass scale for unbroken high accuracy.
- Large LC display with symbols for the measuring functions.
- Zero-setting anywhere within the measuring range.
- PRESET function for entering any given value.
- Metric/inch conversion.
- RS 232 data output.
- SCS calibration certificate provided with each height gauge.



00730043	TESA-HITE 400	415	16
00730044	TESA-HITE 700	715	28
CONSISTING OF:		400	700
00760143	Standard probe insert holder	●	●
00760157	Rechargeable battery, 6V	●	●
00760219	Master piece for establishin the probe constant, nominal dimension to 6,350 mm / 0.250 in	●	●
00760226	Electric pump for creating the air-cushion beneath the gauge base, already mounted	●	●
00760227	Standard probe insert with shank and 5 mm dia. ball tip in tungsten carbide	●	●
04761054	Mains adapter 100 ÷ 200 VAC / 50 ÷ 60 Hz	●	●
04761055	Cable EU for mains adapter	●	●
04761056	Cable US for mains adapter	●	●
OPTIONAL ACCESSORIES:			
04761052	Extension cable, Sub-D 9p/f to 9p/m, 2 m		
04761063	Sub-D 9p/m to USB cable, 2 m		
04760070	RS port, used to connect a digital sensor for perpendicularity measurement		

- $(12 \pm 1,5) \times 10^{-6} \text{ K}^{-1}$
- 10 °C to 40 °C
- 10 °C to 60 °C
- 80 %, non-condensing
- IP40, electronics to IP65 (IEC 60529)
- EN 61326, Class B (with disconnected charger)
- See table opposite
- Shipping packaging
- Identification number
- Declaration of conformity
- SCS calibration certificate

Technical data

	Models		TESA-HITE 400	TESA-HITE 700
		mm	415	715
		in	16	28
	With standard accessory	mm	0 ÷ 570	0 ÷ 870
		in	0 ÷ 22	0 ÷ 34
	With probe insert holder No. 00760057	mm	0 ÷ 625	0 ÷ 925
		in	0 ÷ 24	0 ÷ 36
	With probe insert holder No. S07001622	mm	0 ÷ 795	0 ÷ 1095
		in	0 ÷ 31	0 ÷ 43
	With standard accessory	μm	(2,5 + 4 L) μm (L in m)	
	With standard accessory	in	(0.0001 + 0.000004 L) in (L in in)	
		On flat surfaces: 2 σ < 2 μm / < 0.0001 in Into bores: 2 σ < 3 μm / < 0.00015 in		
	Frontal, mechanical	μm	9	13
		in	0.00035	0.0005
		kg	27	32

Standard Accessories

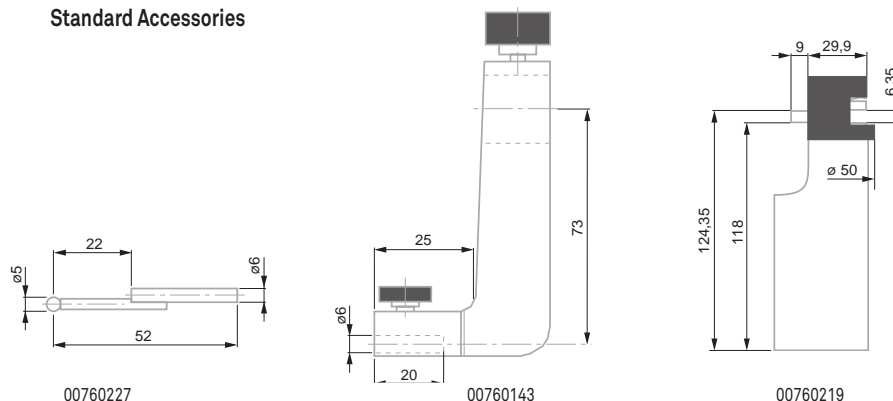

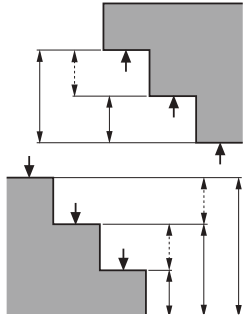

One-dimensional measurement

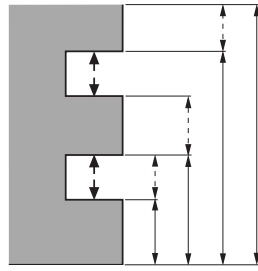

One-dimensional measurement

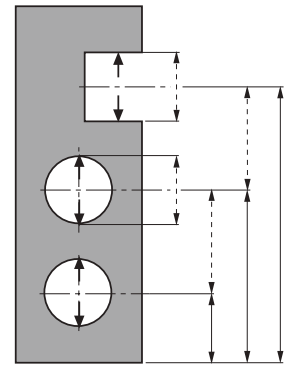

One-dimensional measurement

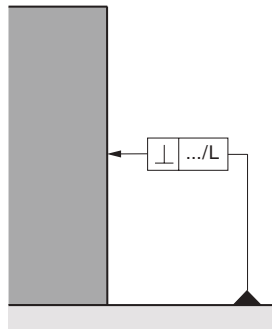

Perpendicularity measurement

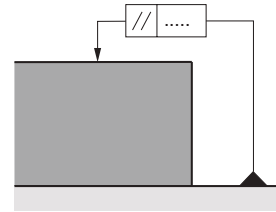

Parallelism measurement

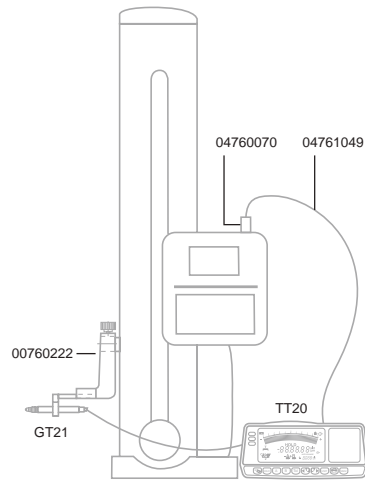

Configuration for perpendicularity measurement

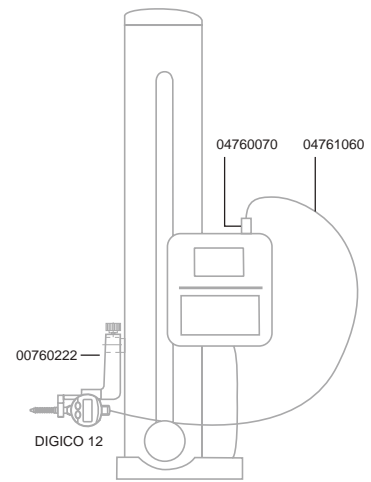

Configuration for perpendicularity measurement

















TESA-HITE Plus M 400 / 700

The added value of the motorised TESA-HITE plus M 400 / 700 is not only noticeable in their technical features, but also in their ease of use. Combine with the programming function, this solution is ideal for recurrent measurements in the shop floor environment.

Advanced functions allow for complex calculations such as those required for two-axis or perpendicularity measurement. These height gauges with outstanding features offer the most attractive price/performance relationship, making them indispensable for the workshop.

- Wide application range.
- Electronics entirely protected from the penetration of liquids and dust particles.
- Integrated air cushion, mounted control panel.
- Easy, intuitive use of the rotary power control.
- Provide all the measuring functions of a dedicated motorised column, including height, diameter, distance, parallelism, perpendicularity, straightness, angle and 2D measurement besides programming, automatic probing cycles, statistical value processing.
- TESA's patented measuring system, opto-electronic.
- Probe insert holder and inserts compatible with those of TESA MICRO-HITE.
- SCS calibration certificate attached to each height gauge.



-  Factory standard
-  Dual LC display, 128 x 63 mm in size.
-  Dual LC display, 128 x 63 mm in size.
- 
 - Upper display field for length values (7 segments/sign) also with symbols for the functions.
 - Lower full dot display field for perpendicularity and straightness along with symbols for all operator-controlled function keys.
 - 7 segment display plus minus sign for the measured values
-  0,0001 / 0,001 / 0,01 mm or 0.00001 / 0.0001 / 0.001 in
-  Incremental glass scale, opto-electronic data capture
-  Main display with a size to 12,7 x 6,4 mm or 6,3 x 4,2 mm for auxiliary display
-  Frontal for models 400 = < 8 µm 700 = < 12 µm
-  Rugged nickel plated gauge base having 3 resting points, finely lapped.
-  1 N. Coupled servomotor for triggering the measuring force.
-  Air bearing for easy displacement on the granite plate. For measuring span, application range and precision: see the table on page N-11. 30 function keys available on the keyboard.
-  Measuring head mounted on a ball-bearing. Electro-motorised head displacement at varying speeds from 7,5 up to 40 mm/s. Manual displacement: ≤ 600 mm/s. Automatic value acquisition with a constant measuring force.
-  RS232
-  Rechargeable batteries, 6V
-  ≈ 60 h, full charging takes 8 hours



- $(12 \pm 1,5) \times 10^{-6} \text{ K}^{-1}$
- 10 °C to 40 °C
- 10 °C to 60 °C
- 80 %, non-condensing
- IP40, IP65 for the electronic control panel (IEC 60529)
- EN 61326, class B (with disconnected battery charger)
- See table opposite
- Shipping packaging
- Identification number
- Declaration of conformity
- SCS calibration certificate

00730045	TESA-HITE plus M 400	405	16
00730046	TESA-HITE plus M 700	705	27
00730057	TESA-HITE plus M 400 + printer	405	16
00730058	TESA-HITE plus M 700 + printer	705	27
CONSISTING OF:		400	700
00760143	Standard probe insert holder	●	●
00760157	Rechargeable battery, 6V	●	●
00760219	Master piece for establishin the probe constant, nominal dimension to 6,350 mm / 0.250 in	●	●
00760226	Electric pump for creating the air-cushion beneath the gauge base, already mounted	●	●
00760227	Standard probe insert with shank and 5 mm dia. ball tip in tungsten carbide	●	●
04761054	Mains adapter 100 ÷ 200 VAC / 50 ÷ 60 Hz	●	●
04761055	Cable EU for mains adapter	●	●
04761056	Cable US for mains adapter	●	●
OPTIONAL ACCESSORIES:			
04760070	RS port, used to connect a digital sensor for perpendicularity measurement		
04761052	Extension cable, Sub-D 9p/f to 9p/m, 2 m		
04761063	Sub-D 9p/m to USB cable, 2 m		
04765008	Thermal paper 57 MM		

Technical Data

	Models		TESA-HITE plus M 400	TESA-HITE plus M 700
		mm	405	705
		in	16	27
	With standard accessory	mm	0 ÷ 560	0 ÷ 860
		in	0 ÷ 22	0 ÷ 33
	With probe insert holder No. 00760057	mm	0 ÷ 615	0 ÷ 915
		in	0 ÷ 24	0 ÷ 35
	With probe insert holder No. S07001622	mm	0 ÷ 785	0 ÷ 1085
		in	0 ÷ 31	0 ÷ 42
	With standard accessory	µm	(2,5 + 3 L) µm (L in m)	
		in	(0.0001 + 0.000003 L) in (L in in)	
	With standard accessory		On flat surfaces: 2 σ = < 1 µm / < 0.00005 in	
			Into bores: 2 σ = < 2 µm / < 0.0001 in	
	Frontal, mecanical	µm	8	12
		in	0.00031	0.00047
		kg	27	32

Standard Accessories

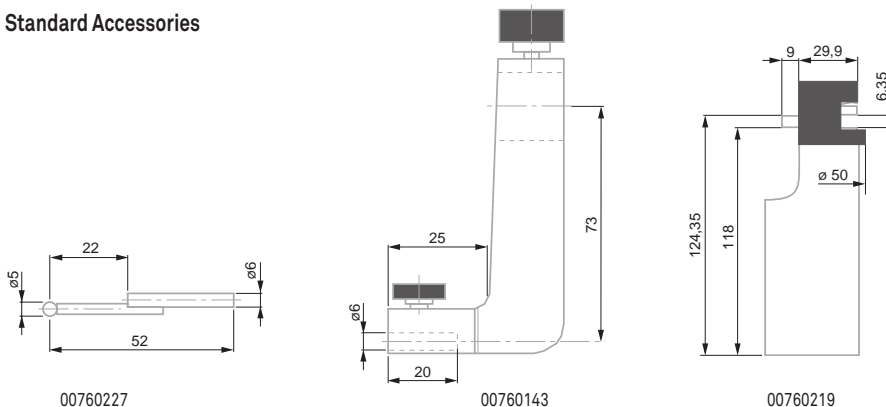

TESA MICRO-HITE 350 / 600 / 900

Autonomous instruments for measurement in one or two coordinate directions of inside dimensions, outside, step, height, depth and distance on geometric elements with flat, parallel or cylindrical surfaces.

The culmination point is automatically entered on the bores and shafts - With memory function "max.", "min." and "max.-min." as dynamic measurement. The use of digital probe TESA IG-13 can also capture perpendicularity, rectitude and parallelism differences, as well as errors of radial and axial runout. Operating results in accordance with ISO 1101.



TESA IG-13

- State-of-the-art concept associated with a high-quality design is the fruit of years of experience in the manufacture of electronic height gauges.
- Ideal for dimensional inspection close to the manufacturing cell. No cumbersome cables to clutter up the working area.
- Fast, simple and reliable probing of the workpiece or holes, especially.
- 3 main gauges available with either a 365, 615 or 920 mm measuring span.
- Numerical display to 0,0005, 0,001, 0,01 and 0,1 mm, or equivalent inch units.
- Extremely accurate measuring of deviations from length, straightness and perpendicularity due to the automatic correction of the bias errors through CAA (Computer Aided Accuracy).
- Coefficient of linear expansion identical to steel ($11,5 \times 10^{-6} K^{-1}$).
- POWER PANEL for value processing and output with interactive display to guide the operator.
- No manual calculation.
- 99 workpiece oriented measurement cycles, programmable. Each cycle includes a number of 64 features with related limits of size.
- Built-in printer for result output or possible use of an external printer unit to get a hard copy in A4 format.
- RS232 data output.
- Every height gauge comes with a SCS calibration certificate.

TESA MICRO-HITE – Power and performance



- Factory standard
- Incremental glass scale with reference point, dividing period of 20 μm . Opto-electronic value capture (TESA patent).
- Frontal, model 350 < 7 μm , model 600 < 9 μm , model 900 < 11 μm
- Rugged nickel plated base with bottom face including 3 resting points finely lapped
- 1,6 \pm 0,25 N (at switch point for value capture)
- 300 mm/s 12 in/s
- Air cushion usable for easy move of the height gauge over the surface plate.
- Measuring span, application range and accuracy as stated in technical data table
- RS232, opto-electronic
- Rechargeable batteries, 6 V, 3,0 Ah or mains adapter
- \approx 12 hours for one battery pack; \approx 2 hours for the pump used to form the air cushion
- $11,5 \times 10^{-6} K^{-1}$
- 10°C to 40°C
- 10°C to 60°C
- 80 % non-condensing
- IP40 (IEC 60529)
- EN 61326-1, Class B (with disconnected charger)
- Net weight (w/o panel nor battery pack) Main gauges 350: 33 kg 600: 38 kg 900: 45 kg
- Shipping packaging
- Identification number
- SCS calibration certificate



No	=			
		mm	in	
00730033	SET MICRO-HITE 350	365	14	
00730034	SET MICRO-HITE 600	615	24	
00730035	SET MICRO-HITE 900	920	36	
CONSISTING OF:		350	600	900
00730021	TESA MICRO-HITE 350 main gauge	●		
00730022	TESA MICRO-HITE 600 main gauge		●	
00730023	TESA MICRO-HITE 900 main gauge			●
00760141	Rechargeable battery pack	●	●	●
00760142	Electric pump for creating the air-cushion beneath the gauge base, already mounted	●	●	●
00760143	Standard probe insert holder	●	●	●
00760150	Master piece for establishing the probe constant, nominal dimension to 20,000 mm / 0.78740 in	●	●	●
00760151	Dust cover for TESA MICRO-HITE 350	●		
00760152	Dust cover for TESA MICRO-HITE 600		●	
00760153	Dust cover for TESA MICRO-HITE 900			●
00760227	Standard probe insert with shank and 5 mm dia. ball tip in tungsten carbide	●	●	●
04761054	Mains adapter 100 ÷ 200 VAC / 50 ÷ 60 Hz	●	●	●
04761055	Cable EU for mains adapter	●	●	●
OPTIONAL ACCESSORIES:				
00760144	Add-on fine adjust device for extra fine movement of the measuring head, complete			
00760157	Rechargeable battery, 6V			
04761023	Cable: miniDIN 8p/m to Sub-D 9p/f, 2m for TT10 and MICRO-HITE manual versions 10/11/12			
04761056	Cable US for mains adapter			

Technical Data

Models		MICRO-HITE	MICRO-HITE	MICRO-HITE
		350	600	900
	mm	365	615	920
	in	14	24	36
With standard accessory	mm	0 ÷ 520	0 ÷ 770	0 ÷ 1075
	in	0 ÷ 20	0 ÷ 30	0 ÷ 42
With probe holder No. 00760057	mm	0 ÷ 575	0 ÷ 825	0 ÷ 1130
	in	0 ÷ 22	0 ÷ 32	0 ÷ 44
With probe holder No. S07001622	mm	0 ÷ 745	0 ÷ 995	0 ÷ 1300
	in	0 ÷ 29	0 ÷ 39	0 ÷ 51
With standard accessory		(2 + 3 L) μm (L in m) (0.0001 + 0.000003 L) in (L in in)		
With standard accessory		2σ = ≤ 1 μm / ≤ 0.00005 in		
Frontal, mechanical	μm	7	9	11
	in	0.00028	0.00035	0.00043
Frontal and lateral with TESA IG-13 probe	μm	6	8	10
	in	0.00024	0.00031	0.00039

Standard Accessories

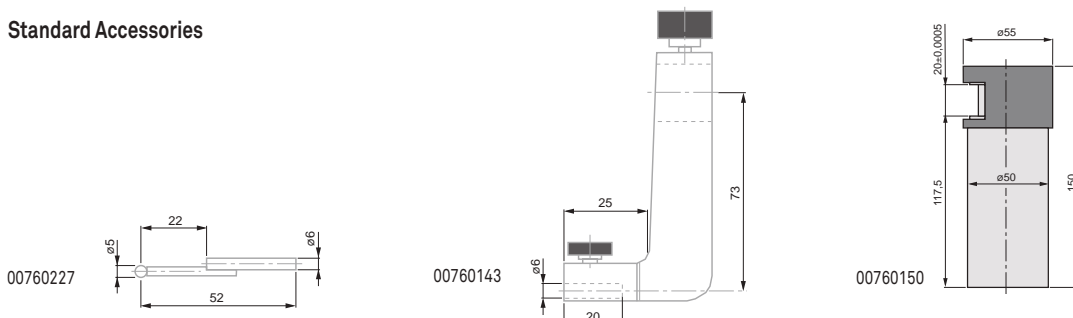

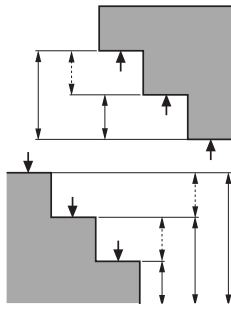

One-dimensional measurement

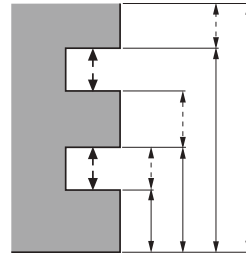

One-dimensional measurement

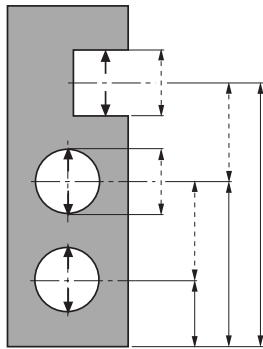

One-dimensional measurement

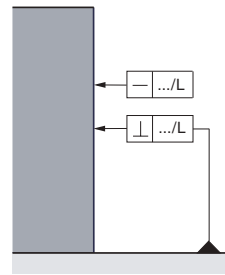

Programme functions for the detection of form and position errors.
With use of a TESA IG-13 digital probe.

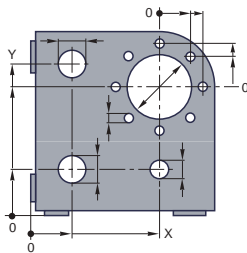

Two-Dimensional Measurement

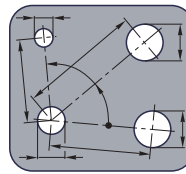

Two-Dimensional Measurement

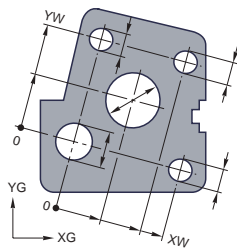

Two-Dimensional Measurement

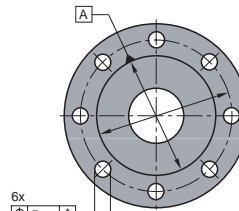

Two-Dimensional Measurement



Control Panel for TESA MICRO-HITE 350 / 600 / 900



See below

Main Display 12,7 x 6,4 mm, 6,3 x secondary display 4,2 mm.

Floating zero

Conversion mm/in

Through TESA MICRO-HITE

IP40 (CEI 60529)



Dual LCD display size 128 x 63 mm.

- Measurement of lengths value display (7 segments / sign) and function symbols (top).
- Measurement of squareness / rectitude display values and symbols (function keys, control by the operator display (points))
- Measured: 7 decades Reduce sign.

PRESET function for entering a given value. Continuous displaying. Manual or automatic triggering of data transfer. Output of pre-defined report with headers in 5 languages plus A4 format using an external printer unit.

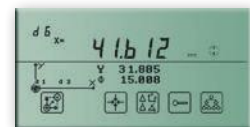

No	=	mm	in
00760163	Power Panel	0,0005 / 0,001 / 0,01 / 0,1	0,00002 / 0,0001 / 0,001 / 0,01 / 0,1
OPTIONAL ACCESSORY:			
04765008	Thermal paper, 57 mm wide		





TESA MICRO-HITE Plus M 350 / 600 / 900

All TESA MICRO-HITE plus M height gauges are unique in that they have exceptional metrological capabilities and can be used intuitively with ease.

This method allows form and position error to be easily and quickly detected by means of a lever-type dial indicator – Check deviations from straightness or parallelism according to ISO 1101 when used in conjunction with TESA IG-13 linked to the Power panel plus M.

- Modular design descending from the successful TESA MICRO-HITE dynasty.
- Also equipped with the unique rotary power control located close to the rugged base. This feature serves for guiding the column that moves on an air cushion, commanding fast motion of the probe insert and triggering all main measuring functions. Its intuitive use allows accurate, easy handling of the column. A simple rotation causes the measuring head to move rapidly, approach the contact point quickly or slowly, probe up- or downward or execute bore measurement.
- Available in three different sizes with a measuring span of 365, 615 or 920 mm.
- Choice between two control panels for value processing and output.
- Metric and inch LC display with a resolution to 0,0001 and 0,001 mm, or inch equivalent.
- Autonomous run through batteries. No cumbersome cable.
- Built-in air bearing for easy displacement over the surface plate.
- Motorised measuring head for fast, accurate probing at each contact point with a constant measuring force.
- TESA μ system for matchless reliability and simplicity.
- High precision through CAA (Computer Aided Accuracy). All correction values stored in the memory still add to the mechanical precision.
- Coefficient of linear expansion matching that of steel ($11,5 \times 10^{-6} \text{ K}^{-1}$).
- RS232 data output.
- SCS calibration certificate delivered with every height gauge.



Factory standard



Incremental glass scale with opto-electronic data acquisition. Grating period: 20 μm . Opto-electronic input (TESA Patent)



Frontal, for model 350 < 5 μm , 600 < 7 μm , 900 < 9 μm .



Rugged nickel plated gauge base having 3 resting points, finely lapped



1 N Coupled for triggering the measuring force



Built-in air-bearing for easy move of the column over the surface plate



Measuring head mounted on a ball-bearing. Motorised head displacement at a varying speed from 7,5 up to 40 mm/s. Manual displacement: $\leq 600 \text{ mm/s}$. Automatic value capture with a constant measuring force.



Field measurement application range and accuracy: see technical data table



Rechargeable 6 V, 3.0 Ah or network adapter 100 ÷ 240 Vac/50 ÷ 60 Hz



$\approx 12 \text{ h}$ after 8 h of charging



TESA μ System



Perpendicularity using TESA IG-13



Perpendicularity using TESATAST

TESA MICRO-HITE plus M

Unrivalled Power, Performances, Ease of use



- 11,5 x 10⁻⁶ K⁻¹
- 10 °C to 40 °C
- 10 °C to 60 °C
- 80 %, no condensation
- IP40 (CEI 60529)
- EN 61326-1, Class B (offline charging)
- Net weight without desks or block batteries. Basic instrument 350: 33 kg, 600: 38 kg, 900: 45 kg
- Shipping packaging
- ID Number
- Declaration of conformity
- Calibration certificate SCS

00730063	Set MICRO-HITE plus M 350	365	14	
00730064	Set MICRO-HITE plus M 600	615	24	
00730065	Set MICRO-HITE plus M 900	920	36	
CONSISTING OF:		350	600	900
00730060	TESA MICRO-HITE plus M 350 main gauge	●		
00730061	TESA MICRO-HITE plus M 600 main gauge		●	
00730062	TESA MICRO-HITE plus M 900 main gauge			●
00760141	Rechargeable battery pack	●	●	●
00760142	Electric pump for creating the air-cushion beneath the gauge base, already mounted	●	●	●
00760143	Standard probe insert holder	●	●	●
00760219	Master piece for establishing the probe constant, nominal dimension to 6,350 mm / 0.250 in	●	●	●
00760151	Dust cover for TESA MICRO-HITE 350	●		
00760152	Dust cover for TESA MICRO-HITE 600		●	
00760153	Dust cover for TESA MICRO-HITE 900			●
00760227	Standard probe insert with shank and 5 mm dia. ball tip in tungsten carbide	●	●	●
04761054	Mains adapter 100 ÷ 200 VAC / 50 ÷ 60 Hz	●	●	●
04761055	Cable EU for mains adapter	●	●	●
04761056	Cable US for mains adapter	●	●	●
OPTIONAL ACCESSORY:				
00760157	Rechargeable battery, 6V			

Technical data

	Models		MICRO-HITE plus M 350	MICRO-HITE plus M 600	MICRO-HITE plus M 900
		mm	365	615	920
		in	14	24	36
	With standard accessory	mm	0 ÷ 520	0 ÷ 770	0 ÷ 1075
		in	0 ÷ 20	0 ÷ 30	0 ÷ 42
	With probe insert holder No. 00760057	mm	0 ÷ 575	0 ÷ 825	0 ÷ 1130
		in	0 ÷ 22	0 ÷ 32	0 ÷ 44
	With probe insert holder No. S07001622	mm	0 ÷ 745	0 ÷ 995	0 ÷ 1300
		in	0 ÷ 29	0 ÷ 39	0 ÷ 51
	With standard accessory		(1,9 + 1,5 L) µm (L in m) (0.0001 + 0.0000015 L) in (L in in)		
	With standard accessory		On flat surfaces: 2 σ ≤ 0,5 µm / ≤ 0.000025 in Into bores: 2 σ ≤ 1 µm / ≤ 0.00005 in		
	Frontal, mechanical	µm	5	7	9
	Frontal and lateral using TESA IG-13	in	0,00020	0,00028	0,00035

Standard Accessories

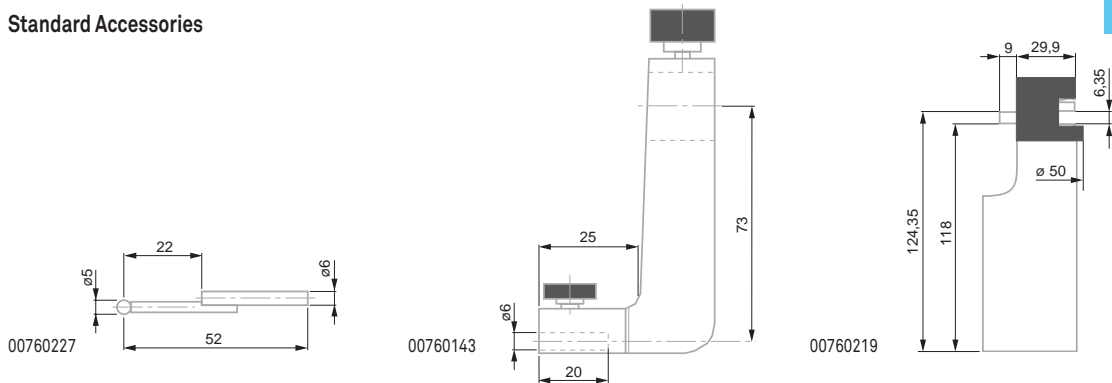

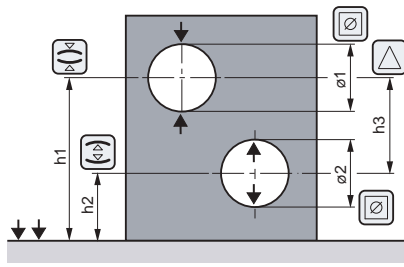

Measurement with change of the probe direction
Probe constant included, considering the culmination point

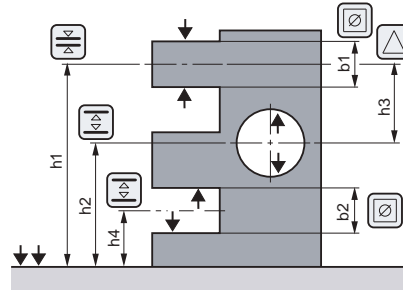

Measurement with change of the probe direction
Probe constant included, disregarding the culmination point

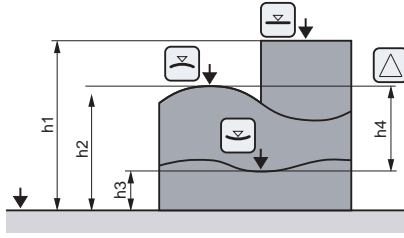

Measurement without change of the probe direction
Probe constant excluded

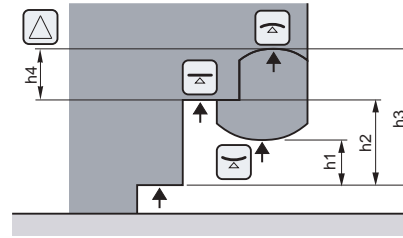

Measurement without change of the probe direction
Probe constant excluded

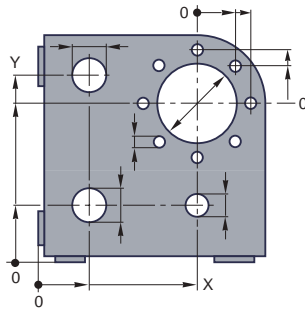

Two-Dimensional Measurement

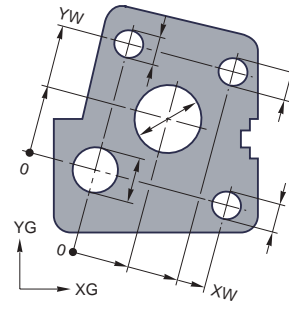

Two-Dimensional Measurement

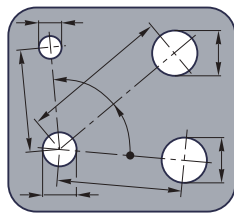

Two-Dimensional Measurement

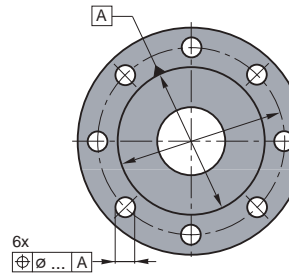

Two-Dimensional Measurement

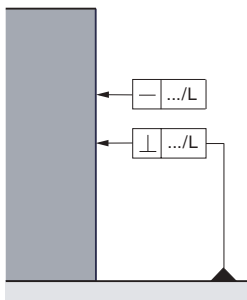

Measurement of form and position errors

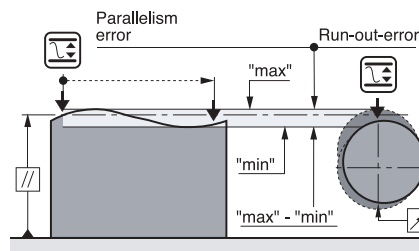

Measurement of form and position errors



Control Panels for TESA MICRO-HITE Plus M 350 / 600 / 900



See opposite



12,7 x 6,4 mm main display, 6,3 x 4,2 or 3,8 x 2,9 mm auxiliary display



mm/in conversion



Via TESA MICRO-HITE plus M



IP50 (IEC 60529)



Declaration of conformity



Keypad with 42 softkeys



Bidirectional RS232, optoelectronic and Centronics



LC dual display, 128 x 63 mm in size.

- Length measurement: 7-segment/digit upper display field for values plus symbols for the functions.

- Straightness or perpendicularity measurement: display field for values plus symbols (function keys). Operator controlled operations (full dot display).

- Measured values: 7-decade display plus minus sign.



PRESET function for entering a given value. Acoustic signal. Manual or automatic triggering of data transfer. Output of predefined reports with headers in 5 languages (plus a programmable one) using an external printer unit (A4 format).



mm



in

00760220

Power Panel for MICRO-HITE plus M with printer

0,0001 / 0,001 / 0,01

0.00001 / 0.0001 / 0.001

00760221

Power Panel for MICRO-HITE plus M

0,0001 / 0,001 / 0,01

0.00001 / 0.0001 / 0.001

OPTIONAL ACCESSORIES:

04765008

Thermal paper, 57 mm wide

04761052

Extension cable, Sub-D 9p/f to 9p/m, 2 m

04761063

Sub-D 9p/m to USB cable, 2 m



TESA IG-13 Probe Set for Perpendicularity Measurement



Factory standard



Shipping packaging

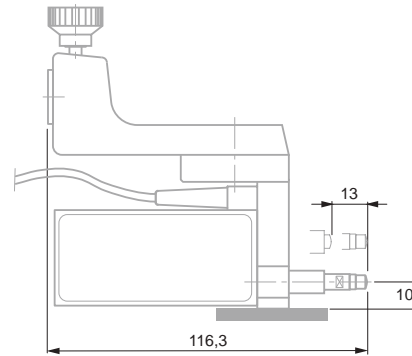

00760140

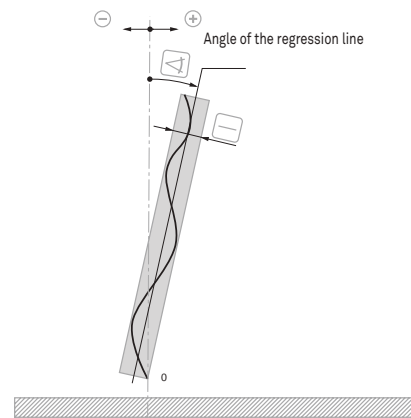
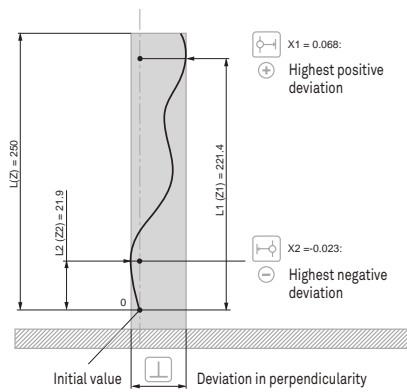

00760140 TESA IG-13 Probe set

CONSISTING OF:

00760138 TESA IG-13 Attachment

00760139 TESA IG-13 Digital probe

OPTIONAL ACCESSORIES:

01960005 Retraction lever

04761047 Connecting cable IG-13/Power Panel plus M 1 m (mini-DIN)



- Factory standard
- 100 mm / 4 in
- 0 to 160 mm 0 to 6.3 in
- 0,001 mm and 0,0001 mm or 0.0001 in and 0.00001 in
- Incremental glass scale with opto-electronic data acquisition. Grating period: 20 µm.
- Error max. tolerated G: see table
- Repeatability limit: see table
- Accuracy class according to DIN 876, Part 1
- finely lapped
- Measuring table (L x P x H) 200 x 300 x 50 mm, Ø column 50 x 300 mm.
- Granite measuring table; dull-chrome plated steel column, hardened and ground.
- 0,63 ± 0,1 N and 1 ± 0,1 N, switchable. Electromotorised activation.
- Numerical interval to 0,001 mm/ 0,0001 in = 10 mm/s; to 0,0001 mm/ 0,00001 in = 5 mm/s; fast displacement = 30 mm/s
- Electro-motorised gauge head displacement; can also be moved manually.
- Via the control panel
- 11,5 x 10⁻⁶ K⁻¹

TESA-µHITE

Compact design with measuring stand included – Sensor equipped with a system for coaxial measuring according to the Abbe principle or using an offset probe relative to the gauge axis. Measures internal, external, height, depth, step and distance dimensions on geometric elements having either a flat, parallel or cylindrical surface – Automatic detection of the culminating point on bores or shafts – Dynamic probing with memory functions "max.", "min." and "max.-min.". The whole system provides the best solution for measuring straightness, flatness and parallelism or inspecting axial and radial runouts depending on the chosen tool configuration.

- Ideal for workpiece inspection close to the production area.
- 100 mm measuring span.
- 0,001 mm and 0,0001 mm or 0.0001 in and 0.00001 in scales intervals.
- Max. perm. error as low as 2 µm (or 1 µm when checking coaxiality).
- Integrated temperature sensor so that the coefficient of linear expansion of each gauge unit matches that of steel (11,5 x 10⁻⁶ K⁻¹).
- Motorised measuring head for fast probing at each point.
- Automatic value capture, controlled over the stability of the measuring force, but also all measured values.
- Constant measuring force through the motor-driven actuator. Switchable.
- No manual calculation needed.
- RS232 data output with direct connection to TESA PRINTER SPC.
- Memory capacity for 99 single values.

Accuracy

Insert's position relative to the axis of the measuring bolt				
	µm	in	µm	in
Coaxial	1,0	0.00005	0,5	0.00002
Offset	2,0	0.0001	1,0	0.00004

Applicable with used standard accessory

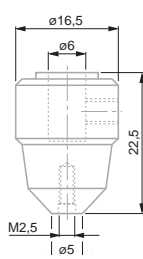

00760195

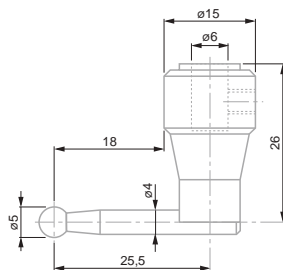

00760197

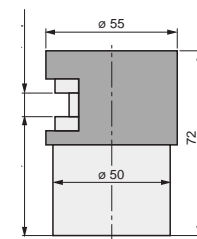

00760192

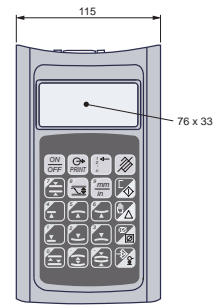

00760204

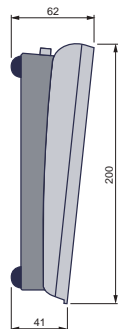

No	TESA-μHITE	mm 0 ÷ 160	in 0 ÷ 6,3	μm Coaxial tip: 1,0 off-centre tip 2,0	μm / in Coaxial tip: 0,5 / 0.00002; off-centre tip 1,0 / 0,00004
----	------------	---------------	---------------	--	---

CONSISTING OF:

- 00760203 TESA measuring support, granite measuring table, size 200 x 300 x 50 mm
- 00730054 TESA-μHITE electronic measuring equipment

CONSISTING OF:

- 038407 1 plastic case
- 00730050 TESA-μHITE probe
- 00760191 Connecting cable Panel / TESA-μHITE
- 00760192 Master piece for establishing the probe constant, nominal dimension 10 mm / 0.39370 in
- 00760195 Axial insert holder M2,5
- 00760197 Probe insert with a 5 mm dia. tungsten carbide ball tip, offset
- 00760204 Control panel, to be connected to TESA-μHITE
- 03510002 Measuring insert TN10W
- 04761054 Mains adapter 100 ÷ 200 VAC / 50 ÷ 60 Hz
- 04761055 Cable EU for mains adapter
- 04761056 Cable US for mains adapter

OPTIONAL ACCESSORIES:

- 00760186 Set of probe inserts for TESA-μHITE
- 04761052 Extension cable, Sub-D 9p/f to 9p/m, 2 m
- 04761063 Sub-D 9p/m to USB cable, 2 m

- 5°C to 40°C
- 10°C to 60°C
- 80 %, non-condensing
- IP50 (IEC 60529)
- EN 61326-1, Class B
- Net weight 16,2 kg (measuring support No. 00760203), net weight 2,6 kg (TESA-μHITE No. 00730050), net weight 1,45 kg (control panel No. 00760204 with cable No. 00760191)
- Shipping packaging
- Identification number
- Declaration of conformity
- SCS calibration certificate

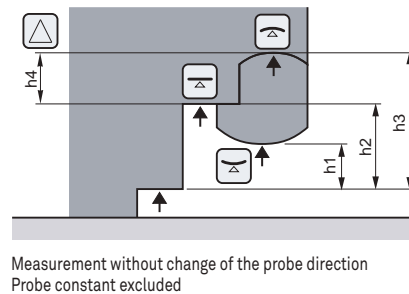
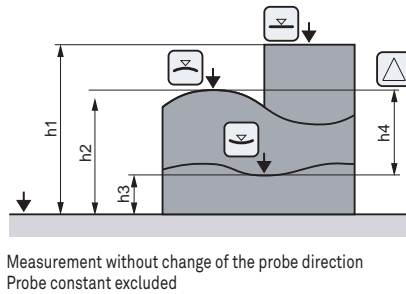

Measurement with change of the probe direction
Probe constant included, considering the culmination point

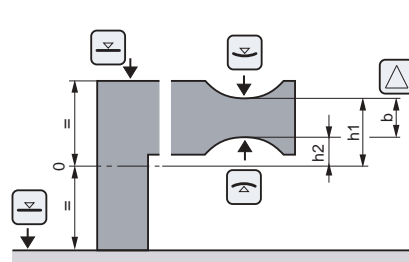
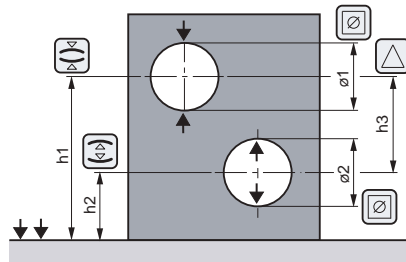

Measurement with change of the probe direction
Probe constant included, disregarding the culmination point

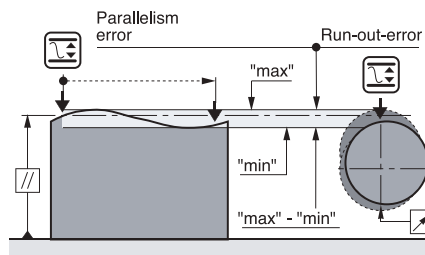
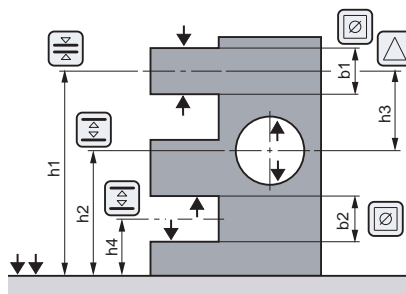



Shipping packaging



Declaration of conformity

Optional Accessories for TESA-μHite



00760194	Axial probe holder for probe inserts with a M1,4 thread
00760196	Axial probe holder for probe inserts with a M3 thread
00760198	Radial probe holder with a 4 mm dia. mounting bore
00760199	Universal probe insert holder with a 4 mm dia. clamping shank (used in conjunction with radial probe holder No. 00760198). M1,4 plus M3 threads (2 x 2) for the probe inserts
00760200	Probe insert with a 5 mm dia. tungsten carbide ball tip. Also with a 4 mm dia. fixing rod for use with radial probe holder insert No. 00760198.
00760201	Probe insert with a 3 mm dia. tungsten carbide ball tip. Also with a 4 mm dia. fixing rod for use with radial probe holder No. 00760198.
00760202	Spare batteries for control panel No. 00760204, 6 Vdc/1,2 Ah.
00760207	Swivel support for control panel

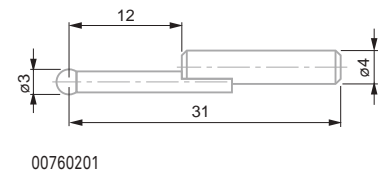
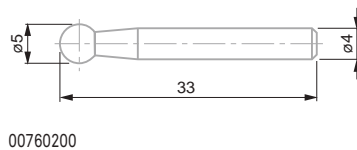
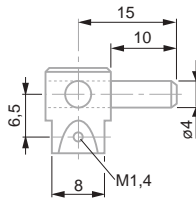
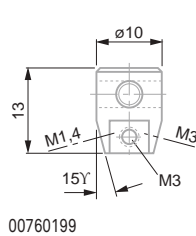
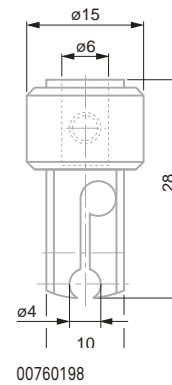
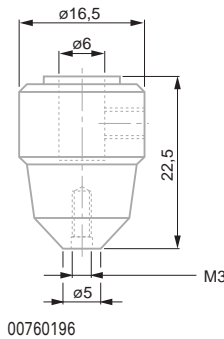
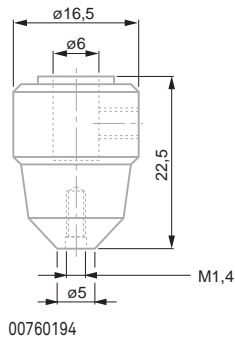

Sets of Accessories for Height Gauges



Shipping packaging



Declaration of conformity



00760232 Starter accessory kit with 4 elements for TESA Height Gauges

CONSISTING OF:

00760061 Probe insert with a 3 mm dia. carbide ball tip

00760075 Probe insert with a carbide disc tip E = 2 mm / Ø 14 mm for grooves, slots, centering shoulders etc.

00760082 2 mm dia. probe insert with a small cyl. carbide face

00760094 Probe inserts with a stainless steel shank, hardened. Also with one flat and one spherical carbide measuring face. Interchangeable shank.

059215 Plastic box

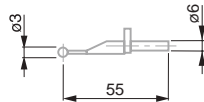

00760061

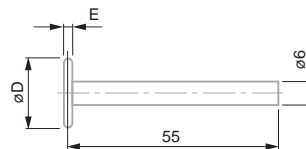

00760075

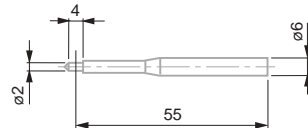

00760082

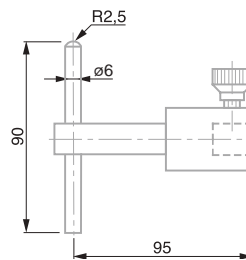

00760094





Shipping packaging

Declaration of conformity

Sets of Accessories for Height Gauges

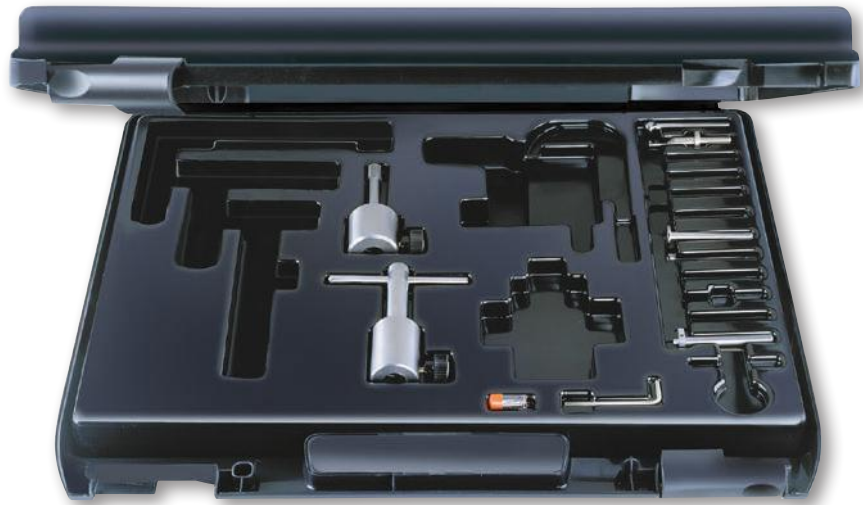

No =

00760173 Starter accessory kit with 8 elements for TESA Height Gauges

CONSISTING OF:

- 00760061** Probe insert with a 3 mm dia. carbide ball tip
- 00760060** Probe insert with a 10 mm dia. carbide ball tip
- 00760075** Probe insert with a carbide disc tip E = 2 mm / Ø 14 mm for grooves, slots, centering shoulders etc.
- 00760093** Probe insert with a cylindrical, tungsten carbide measuring face (10 mm dia., 12 mm long). Stainless steel body, hardened.
- 00760094** Probe inserts with a stainless steel shank, hardened. Also with one flat and one spherical carbide measuring face. Interchangeable shank.
- 00760228** Probe insert dia. 1 mm with shank and ball tip in tungsten carbide
- 00760229** Probe insert dia. 2 mm with shank and ball tip in tungsten carbide
- 00760230** Probe insert dia. 3 mm with shank and ball tip in tungsten carbide

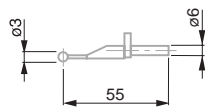

00760061

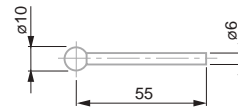

00760060

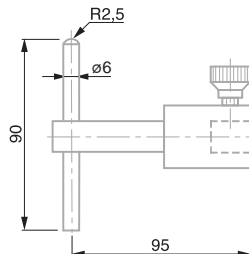

00760094

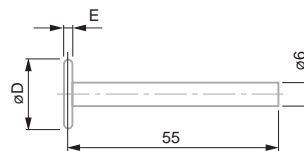

00760075

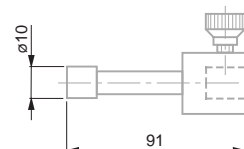

00760093

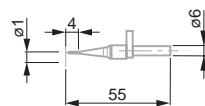

00760228

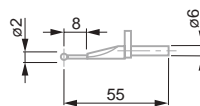

00760229

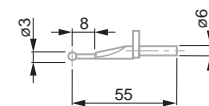

00760230



Sets of Accessories for Height Gauges



Shipping packaging



Declaration of conformity

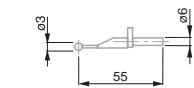

00760061

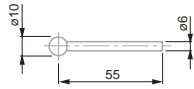

00760060

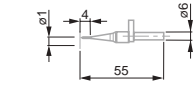

00760228

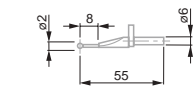

00760229

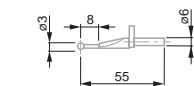

00760230

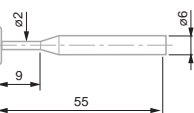

00760074

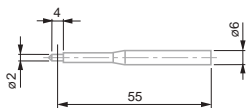

00760082

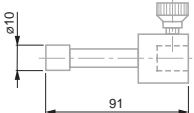

00760093

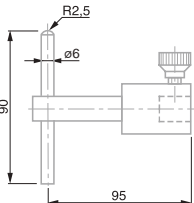

00760094



00760148 Full accessory set with 17 elements for TESA Height Gauges

CONSISTING OF:

- 00760057** Probe insert holder for extending the application range
- 00760060** Probe insert with a 10 mm dia. carbide ball tip
- 00760061** Probe insert with a 3 mm dia. carbide ball tip
- 00760066** Probe insert \varnothing 2,2 mm (for M3 to M16 threads) with carbide, barrel-shaped measuring faces for cylindrical bores as well as for determining the position of metric inside threads (or similar).
- 00760067** Probe insert \varnothing 4,5 mm (for M6 to M48 threads) with carbide, barrel-shaped measuring faces for cylindrical bores as well as for determining the position of metric inside threads (or similar).
- 00760068** Probe insert \varnothing 9,7 mm (for M12 to M150 threads) with carbide, barrel-shaped measuring faces for cylindrical bores as well as for determining the position of metric inside threads (or similar).
- 00760074** Probe insert with a carbide disc tip $E = 1$ mm / \varnothing 4,5 mm for grooves, slots, centering shoulders etc.
- 00760075** Probe insert with a carbide disc tip $E = 2$ mm / \varnothing 14 mm for grooves, slots, centering shoulders etc.
- 00760076** Probe insert with a carbide disc tip $E = 3$ mm / \varnothing 19 mm for grooves, slots, centering shoulders etc.
- 00760082** 2 mm dia. probe insert with a small cyl. carbide face
- 00760086** Probe insert holder for depth up to 110 mm ($L = 75$ mm)
- 00760087** Probe insert holder for depth up to 185 mm ($L = 150$ mm)
- 00760094** Probe inserts with a stainless steel shank, hardened. Also with one flat and one spherical carbide measuring face. Interchangeable shank.
- 00760228** Probe insert dia. 1 mm with shank and ball tip in tungsten carbide
- 00760229** Probe insert dia. 2 mm with shank and ball tip in tungsten carbide
- 00760230** Probe insert dia. 3 mm with shank and ball tip in tungsten carbide

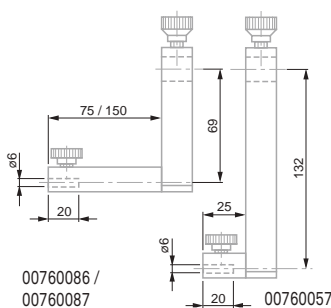

00760086 /
00760087

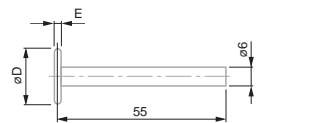

00760076

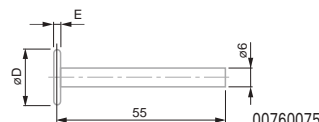

00760075

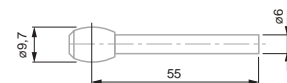

00760068

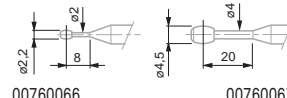

00760066

00760067





Shipping packaging

Declaration of conformity

Sets of Accessories for Height Gauges



00760175 Set of probe inserts for TESA-HITE, TESA-HITE plus M, TESA-HITE magna, MICRO -HITE and MICRO-HITE plus M

CONSISTING OF:

00760177 Probe insert holder

00760178 Hardened steel rod for grooves, centring shoulders, blind bores etc, angled through 8°

00760179 Tungsten carbide cylindrical rod for depth measurement

00760180 Probe inserts with a 0,9 mm dia. hardened steel ball tip

00760181 Probe inserts with a 1,9 mm dia. hardened steel ball tip

00760182 Probe inserts with a 1,9 mm dia. hardened steel ball tip

00760183 Hardened steel probe insert with a cone-shaped measuring face, 8 mm dia.

00760184 Extension, 20 mm, with a M3 thread for inserts with M3 thread

00760185 Extension, 20 mm, with a M3 thread for inserts with M2,5 thread

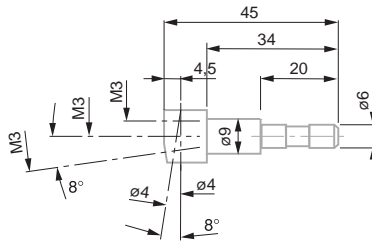

00760177

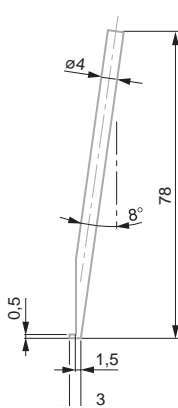

00760178

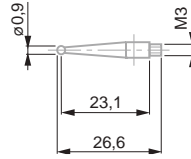

00760180

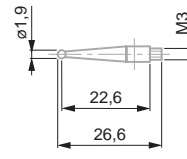

00760181

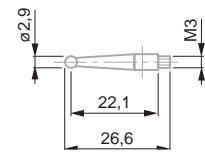

00760182

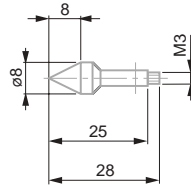

00760183

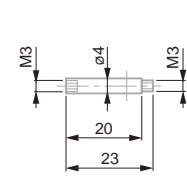

00760184

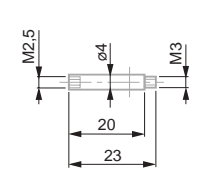

00760185

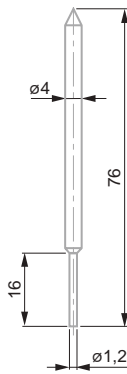

00760179

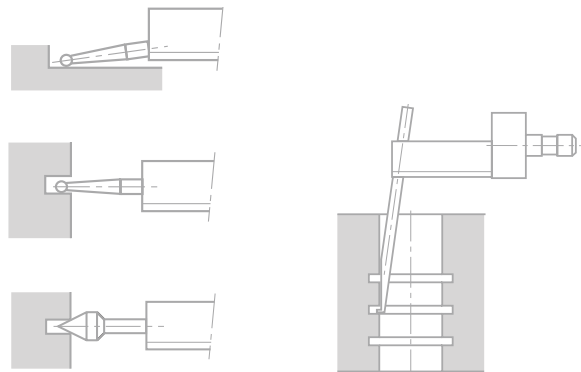

Sets of Accessories for Height Gauges



00760186	Set of probe inserts for TESA-μHITE
<i>CONSISTING OF:</i>	
00760178	Hardened steel rod for grooves, centring shoulders, blind bores etc, angled through 8°
00760179	Tungsten carbide cylindrical rod for depth measurement
00760180	Probe inserts with a 0,9 mm dia. hardened steel ball tip
00760181	Probe inserts with a 1,9 mm dia. hardened steel ball tip
00760182	Probe inserts with a 2,9 mm dia. hardened steel ball tip
00760183	Hardened steel probe insert with a cone-shaped measuring face, 8 mm dia.
00760184	Extension, 20 mm, with a M3 thread for inserts with M3 thread
00760185	Extension, 20 mm, with a M3 thread for inserts with M2,5 thread
00760187	Probe insert holder



Shipping packaging



Declaration of conformity

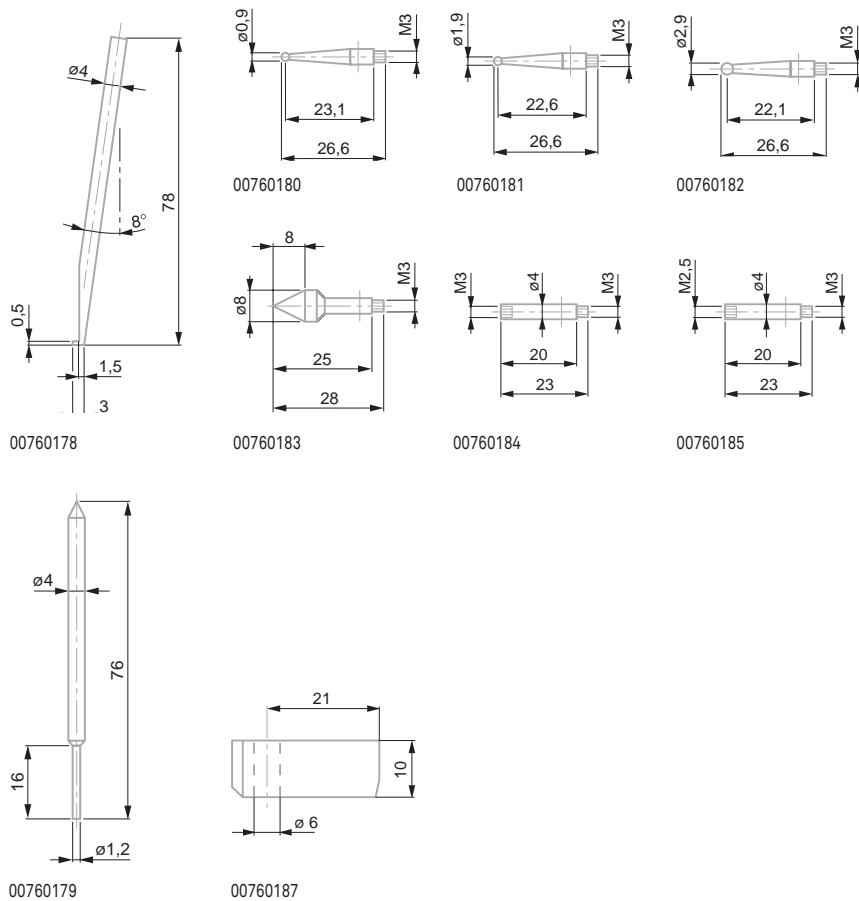

- Factory standard
- Shipping packaging

Probe Holder No. 00760223 for Inserts with 8 mm Diameter



00760223 Probe holder for inserts with 8 mm diameter

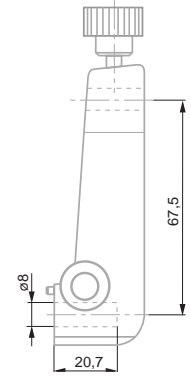

- Factory standard
- Shipping packaging

Optional Accessories for Use with Insert Holder No. 00760223



- 0071684815 Probe insert with a 4 mm dia. tungsten carbide ball tip
- 0071684816 Probe insert with a 6 mm dia. tungsten carbide ball tip
- 0071684817 Long probe insert with a 10 mm dia. tungsten carbide ball tip
- 0071684818 Probe insert with a 1 mm dia. steel tip, hardened. Also with adjustable shank for depth measurement.
- 0071684819 Probe insert with cone-shaped measuring face in hardened steel for $\varnothing 5 \div 20$ mm
- 0071684820 Probe insert with cylindrical measuring face in hardened steel, $\varnothing 10$ mm, 12 mm long
- 0071684822 Probe insert with cone-shaped measuring face in hardened steel, $\varnothing 0,5 \div 5,5$ mm
- 0071684825 Probe insert with a 6 mm dia. tungsten carbide ball tip
- 0071684826 Attachment for interchangeable inserts with M1,4 thread. Supplied with 1 insert No. 01860201 having a 1 mm dia. carbide ball tip.
- 0071684827 Probe insert with disc-shaped face $\varnothing 12$ mm, 3 mm wide
- 0071684828 Attachment for interchangeable insert with M1,4 thread. Supplied with 2 probe inserts No. 0186020 having a 2 mm dia. carbide ball tip
- 0071684829 Probe insert with a 10 mm dia. tungsten carbide ball tip
- 0071684832 Probe insert with a 8 mm dia. tungsten carbide ball tip

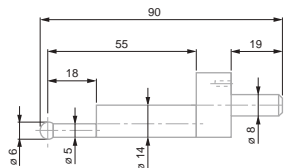
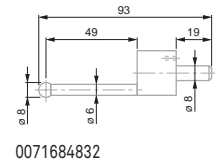
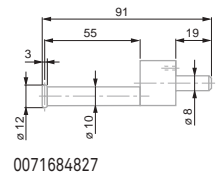
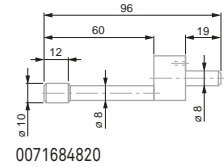

0071684825

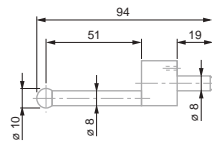

0071684829

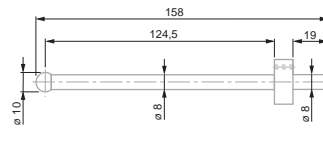

0071684817

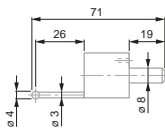

0071684815

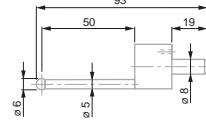

0071684816

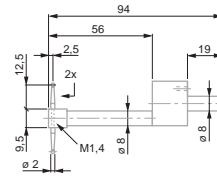

0071684828

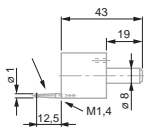

0071684826

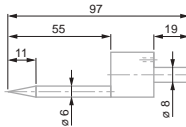

0071684822

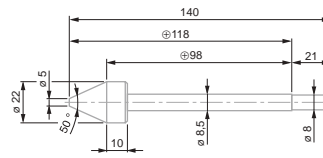

0071684819

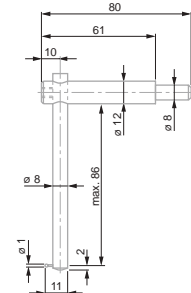

0071684818



Accessories for Measuring Perpendicularity by Means of a Dial Test Indicator

Used with TESA MICRO-HITE plus M, TESA MICRO-HITE, TESA-HITE 400/ 700 and TESA-HITE plus M 400/ 700.

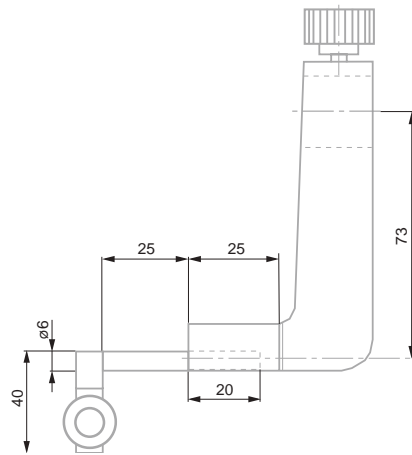

00760222 Probe insert holder for a dial test indicator (lever-type)



- Factory standard
- Floating zero
- DIN 862
For lengths up to
600 mm = 30 µm
1000 mm = 40 µm
- Steel base,
hardened
- Wooden case
- Declaration of
conformity
- Identification
number
- Slider with inter-
changeable scriber.
Also with back
mounted clamping
holder having
a 8 mm diameter.
Slider with locking
screw and fine
adjust device.
Base has a ground
face with dust
grooves. Top face
also ground.
- Preset and Hold
functions



ETALON Height and Scribing Gauges with Digital Display

Electronic height and scribing gauges

- Resolution to 0,01 mm/0.005 in
- RS232 interface

No	mm	in	Column, mm	Base (L x H x W) mm
07739001	0 ÷ 300	0 ÷ 12	25 x 6	60 x 40 x 100
07739002	0 ÷ 600	0 ÷ 24	30 x 12	110 x 50 x 160
07739003	0 ÷ 1000	0 ÷ 40	30 x 12	110 x 50 x 160

Accessories for ETALON Height and Scribing Gauges with Digital Display



07769005



07769006

No				
		Suitable for models	Length, mm	
07769001	Scriber for 300 mm length 65 mm	300	65	
07769003	Scriber for 6 to 1000 mm, length 75 mm	600, 1000	75	
07769005	Holder to replace the scriber			
07769006	Rotating and tilting version with a 8 mm dia. shank. To be used with No. 07769005			





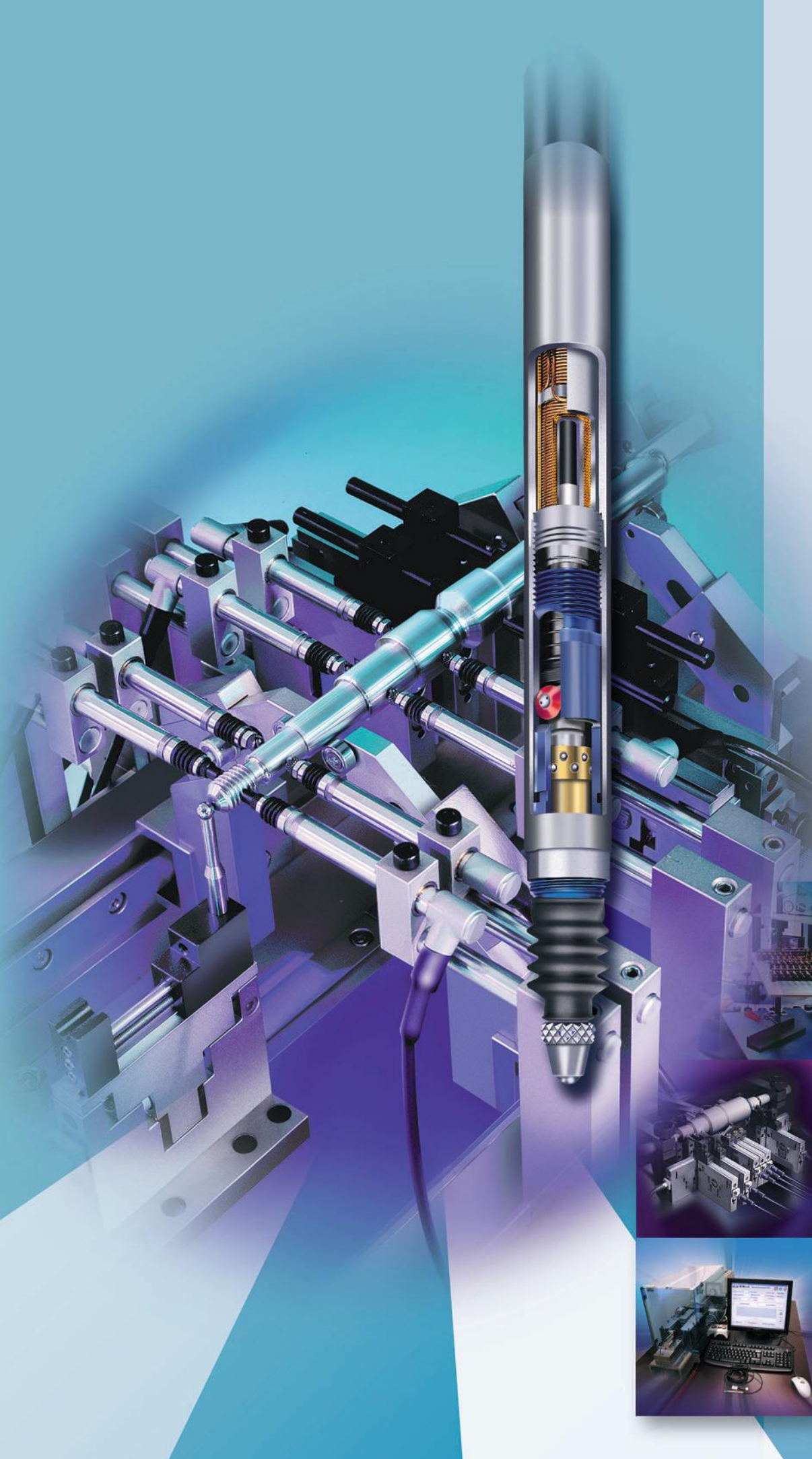

Electronic Length Measuring Equipment



TESA INDUCTIVE PROBES AND ELECTRONIC EQUIPMENT

TESA probes: At the cutting edge of technology

TESA develops, manufactures and remains a leader in the inductive probe sector with an experience of more than 40 years. It offers a complete and unique line of probes designed to meet the requirements of varied as well as demanding applications.

Dimensional inspection of medium and large batches of parts in multigauging fixtures represents a major application area where measuring speed coupled with a high level of accuracy is needed.

High precision inductive probes (type GTL-21 HP) are, for example, also suited for the measurement of gauge blocks. The display resolution can reach a digital step of $0,01 \mu\text{m}$!

On request, TESA probes can be supplied in versions compatible with the electronic equipment of other suppliers.

Typical qualities of TESA inductive probes : excellent repeatability, durability and longevity

All TESA inductive axial movement are mounted on a ball bearing with the exception of miniature models.

The ball bearing guidance system is insensitive to any radial force exerted on the probe housing. An anti-rotation guiding system ensures perfect movement of the mechanical guide.

The axial probe guide system is effectively protected against penetration of liquids (oils) or solids (dust) by sealing bellows of high elastic quality. Under normal conditions, the standard nitrile elastomer bellows provide sufficient protection against oils and solvents. For applications where the probes remain in prolonged contact with coolants or lubricants and aggressive chemicals, Viton bellows are recommended. Viton is a fluorelastomer resistant to the heat of oils and aggressive chemicals.

The retraction (lifting) of the measuring bolt rod can be made by the suction of air (vacuum) accumulated within the probe thanks to the airtightness provided by the sealing bellows. This method of working principle does not use any mechanical device ensures the operation of the guidance system in an optimal manner. Similarly, the probe can be moved into its measuring position by a pneumatic activation (pressure), depending on the probe model.

Inserts (measuring inserts) can be replaced or exchanged. A wide choice of geometrical forms and sizes are available

The measuring force can be adjusted by changing the spring, depending on the probe model.

The probes integrate an electronic amplifier of the signal without relying on any mechanical conversion device. Thus, these probes are distinguished by their high repeatability and very low hysteresis errors.

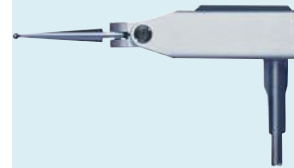
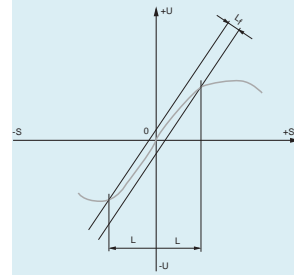

GT-31

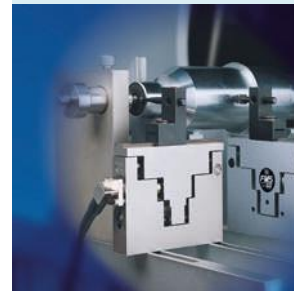

Probe FMS



TT20



USB probe



Wireless probe



Application examples of measuring functions

Measuring external dimensions with use of a measuring stand, snap gauge etc.

Single measurements with positive polarity sign (+A)

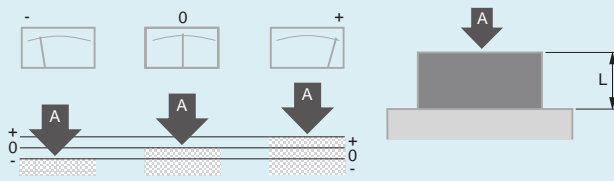

Inversion of polarity with displayed value equal to bore or diameter

Single measurements with negative polarity sign (-A)

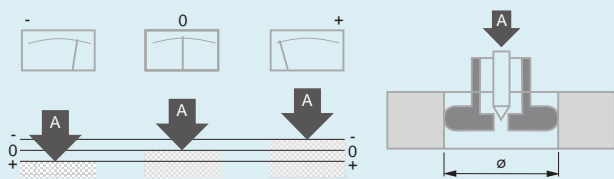

Measuring external dimensions regardless of form and position errors

Sum measurements with positive polarity signs (+A +B)

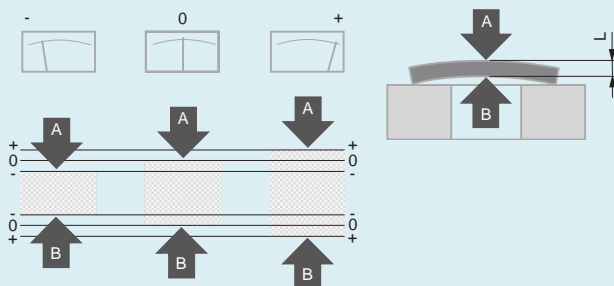

Cone, inclination and step measurements.

Difference measurements with opposite polarity signs (+A -B)

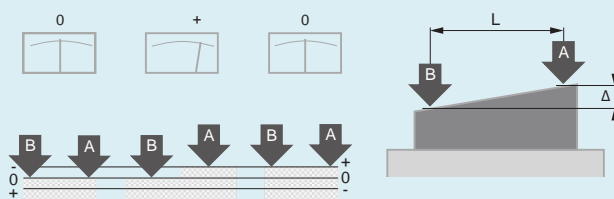

Establishing form and position errors with "max - min" memory function as in the example for runout errors

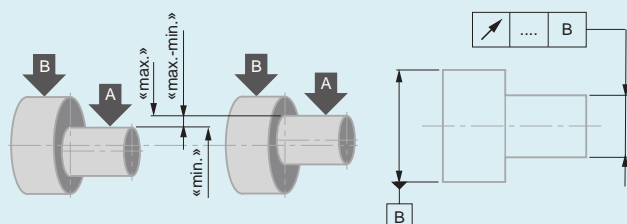

For the acquisition of measured values, TESA offers a complete family of probes and measuring instruments for the most demanding applications. The probes, supplied in standard execution, do not need any form of adaptation. They function on the inductive half-bridge principle.

The market offers other equipment using probes that partly operate on the principle of a differential transformer and these are known as LVDT (Linear Variable Differential Transformer) probes.

TESA also offers a range of probes compatible with other electronic equipment, using an adaptor and a connector depending on the origin of the equipment. A description of TESA standard half-bridge and LVDT probes is provided below.

Standard half-bridge probes for TESA equipment

OPERATING PRINCIPLE

All TESA electronic probes (value sensors) work based on the inductive principle with mechanical contact of the workpiece.

They are fitted with a coil system inducing an alternating output voltage that depends on the the position of the ferro magnetic core. When symmetrically positioned – i.e. at electrical zero – no voltage is impressed. A move of the core, which may be attached to the measuring bolt while the measurand is being taken, causes the inductance to change. This change generates a signal that is amplified and rectified before being displayed and further output. Depending on the instrument type, the analogue signal will be shown on a voltmeter or a numerical display after a digital transformation.

Unambiguous assessment of the measurand (at bolt position) to the signal (displayed value) is the main characteristic of analogue value acquisition. One of its distinct advantages lies in the value primarily displayed, which will be reproduced in the event of a power cut (switch-off or power failure).

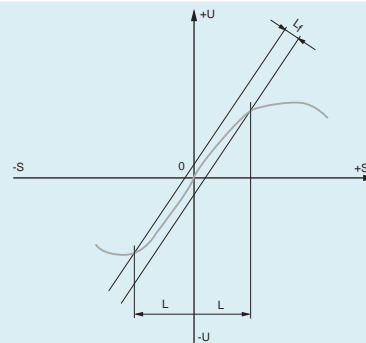

Inductive measuring
 S: Travel
 U: Output current
 0: Electrical zero
 L: Linearity range
 Lf: Linearity error

TESA Standard Half-Bridge Probes for TESA Electronic Equipment

These probes have two serial coils with middle output mounted side by side, which are energized by a sinusoidal alternation signal at 13 kHz. Both are linked together to a Wheatstone bridge over an additional half-bridge.

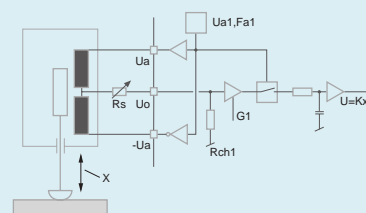

Wiring plan of half-bridge probes

TESA LVDT Probes

These probes are based on a Linear Variable Differential Transformer (LVDT). They have three coils, i.e. one primary coil being energized by a sinusoidal alternation at 5 kHz, and two secondary coils connected in opposite phase, which generate the output current proportional to the measuring travel.

Available upon request.

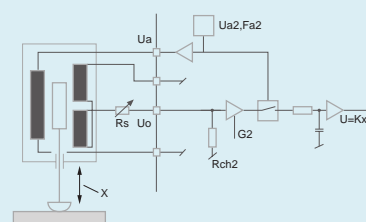

Wiring plan of LVDT probes



Multiple application possibilities

TESA probes have been designed for applications for use with instruments for internal and external measurements, measuring supports or special measuring systems. For such applications, different probe executions can be supplied such as probes with an axial measuring bolt or parallel guides, refer also to angle lever probes. In addition, there are also special executions developed for multi-gauging inspection fixtures or 'in-process' inspection stations, which enable an economy in the number of components needed. Apart from a few exceptions, the measuring operations executed are always comparative measurements with reference to a standard such as a gauge block, a setting ring or any other component that can be used as a master.

The measurements are extremely accurate. Bias error influence is negligible compared to the budget for measuring uncertainty given the fact that the comparison is being established between two almost practically equal values

Random errors also lose their influence in a procedure where the display setting is made under the same conditions as the subsequent probing measurements

TESA measuring instruments are equipped with an analogue and/or digital display, depending on the model.

Internal processing of measured values

Depending on the application, the electrical signals are processed in different ways within the instrument.

Mathematical Data Processing

The signals can be processed with positive polarity sign as well as negative polarity sign. The use of a single probe enables single measurement of internal or external dimensions while the combination of the signals of two probes produces either a "sum measurement" or a "difference measurement".

Value Storage

The storage of measured values in the memory ensures the reliability of dynamic measuring cycles. The characteristic values are the two minimum and maximum values or the difference between the smallest and largest value acquired while measuring form or position errors.

Classification of Values

The measured values can be classified after the entering of limit deviations. In this case, the control signals can be used by an external peripheral unit.

Components of a TESA inductive probe

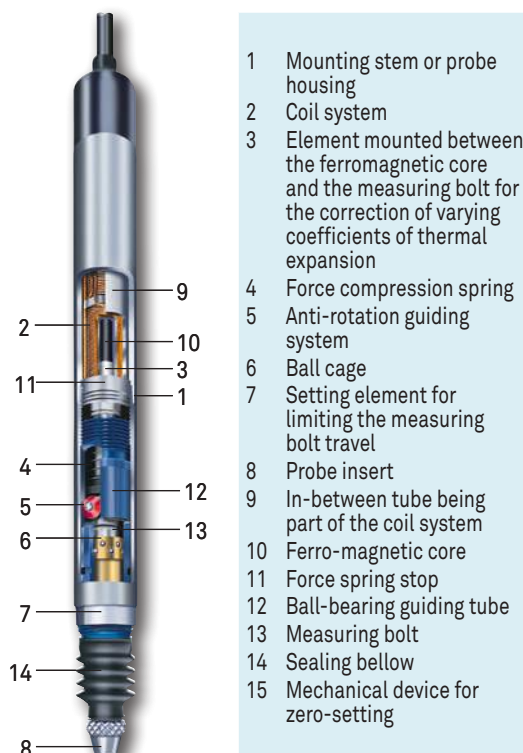

Sensitivity of TESA half-bridge probes for TESA electronic interfaces and electronic displays

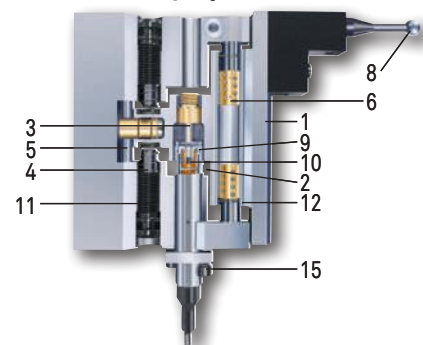

Sensitivity	73,75 mV/V/mm
	29,50 mV/V/mm (GT 61, GT 62)
	7,375 mV/V/mm (GT 61S, GT 62S)
	49,17 mV/V/mm (FMS 130, FMS 132)
All given values are valid for the following reference conditions :	
Drive voltage	3 V
Drive frequency	13 kHz
Adjustment load	2 kΩ









Probes with Axial Movement, Ø 8 mm

							
	No	=	Measuring range, mm	Measuring bolt travel, mm	Cable output	Measuring bolt retraction	Sealing bellows
	03210904	GT 21	± 1 mm	4,3	Axial	Mechanical	Nitrile
	03210924	GT 22	± 1 mm	4,3	Radial	Mechanical or vacuum	Nitrile
	03230057	GTL 21	± 2 mm	4,3	Axial	Mechanical	Viton
	03230072	GTL 211	± 2 mm	4,3	Axial	Vacuum	Viton
	03230056	GTL 22	± 2 mm	4,3	Radial	Vacuum	Viton
	03230027	GT 27	± 2 mm	10,3	Axial	Mechanical	Viton
	03230073	GT 271	± 2 mm	10,3	Axial	Mechanical / vacuum	Viton
	03230026	GT 28	± 2 mm	10,3	Radial	Mechanical / vacuum	Viton
	03230041	GT 61	± 5 mm	10,3	Axial	Mechanical	Viton
	03230042	GT 62	± 5 mm	10,3	Radial	Mechanical / vacuum	Viton
	03230036	GT 21 HP	± 0,2 mm	4,3	Axial	Mechanical	Nitrile
	03230021	GT 22 HP	± 0,2 mm	4,3	Radial	Mechanical or vacuum	Nitrile



* Nominal value of the measuring force at electrical zero, max. deviation $\pm 25\%$

** For an amplitude of 10 % to the last value of the measuring range

 Nominal measuring force*, N	 Mobile weight, g	 Mechanical limit max frequency** (Hz)	 Partially removable	 Répeatability, μm	 Max. permissible error for deviations in linearity, μm (L in mm)	 Hysteresis, μm	 Protection level (IP XX), as per IEC 60529
0,63	6	60	Yes	0,01 μm	$0,2 + 3 \cdot L^3 \mu\text{m}$	0,02	IP65
0,63	6	60	Yes	0,01 μm	$0,2 + 3 \cdot L^3 \mu\text{m}$	0,02	IP65
0,63	6	60	Yes	0,01 μm	$0,2 + 2,4 \cdot L^2 \mu\text{m}$ BPX: $0,2 + 0,8 \cdot L \mu\text{m}$	0,02	IP65
0,63	6	60	Yes	0,01 μm	$0,2 + 2,4 \cdot L^2 \mu\text{m}$ BPX: $0,2 + 0,8 \cdot L \mu\text{m}$	0,02	IP65
0,63	6	60	Yes	0,01 μm	$0,2 + 2,4 \cdot L^2 \mu\text{m}$ BPX: $0,2 + 0,8 \cdot L \mu\text{m}$	0,02	IP65
0,63	8	60	Yes	0,05 μm	$0,2 + 3 \cdot L^3 \mu\text{m}$	0,05	IP65
0,63	8	60	Yes	0,05 μm	$0,2 + 3 \cdot L^3 \mu\text{m}$	0,05	IP65
0,63	8	60	Yes	0,05 μm	$0,2 + 3 \cdot L^3 \mu\text{m}$	0,05	IP65
0,90	8	60	Yes	0,05 μm	$1 + 4 \cdot L \mu\text{m}$ BPX: $0,6 + 0,8 \cdot L \mu\text{m}$	0,05	IP65
0,90	8	60	Yes	0,05 μm	$1 + 4 \cdot L \mu\text{m}$ BPX: $0,6 + 0,8 \cdot L \mu\text{m}$	0,05	IP65
0,63	6	60	No	0,01 μm	$0,07 + 0,4 \cdot L \mu\text{m}$	0,01	IP64
0,63	6	60	No	0,01 μm	$0,07 + 0,4 \cdot L \mu\text{m}$	0,01	IP64











Probes with Axial Movement, Ø 8 mm, with Activation of the Measuring Bolt by Pneumatic Pressure

			 Measuring range, mm	 Measuring bolt travel, mm	 Cable output	 Sealing bellows
	03230060	GTL 212	± 1,5 mm	3,2	Axial	Viton
	03230054	GTL 222	± 1,5 mm	3,2	Radial	Viton
	03230067	GTL 212-A	± 1,5 mm	3,2	Axial	Without bellows
	03230063	GTL 222-A	± 1,5 mm	3,2	Radial	Without bellows
	03230061	GT 272	± 2 mm	10,3	Axial	Viton
	03230053	GT 282	± 2 mm	10,3	Radial	Viton
	03230068	GT 272-A	± 2 mm	10,3	Axial	Without bellows
	03230069	GT 282-A	± 2 mm	10,3	Radial	Without bellows
	03230062	GT 612	± 5 mm	10,3	Axial	Viton
	03230055	GT 622	± 5 mm	10,3	Radial	Viton
	03230070	GT 612-A	± 5 mm	10,3	Axial	Without bellows
	03230071	GT 622-A	± 5 mm	10,3	Radial	Without bellows



* Nominal value of the measuring force at electrical zero, max. deviation $\pm 25\%$

** For an amplitude of 10% to the last value of the measuring range

 Measuring force, nominal*, N	 Mobile weight, g	 Max. mechanical frequency limit** (Hz)	 Partially removable	 Repeatability, μm	 Max. permissible error for deviations in linearity, μm (L in mm)	 Hysteresis, μm	 Protection level (IP XX), as per IEC 60529
1,2	6	60	Yes	0,015 μm	$0,2 + 2,4 \cdot L^2 \mu\text{m}$ BPX: $0,2 + 0,8 \cdot L \mu\text{m}$	0,02	IP65
1,2	6	60	Yes	0,015 μm	$0,2 + 2,4 \cdot L^2 \mu\text{m}$ BPX: $0,2 + 0,8 \cdot L \mu\text{m}$	0,02	IP65
0,2	6	60	Yes	0,015 μm	$0,2 + 2,4 \cdot L^2 \mu\text{m}$ BPX: $0,2 + 0,8 \cdot L \mu\text{m}$	0,02	IP50
0,2	6	60	Yes	0,015 μm	$0,2 + 2,4 \cdot L^2 \mu\text{m}$ BPX: $0,2 + 0,8 \cdot L \mu\text{m}$	0,02	IP50
1,0	8	60	Yes	0,05 μm	$0,2 + 3 \cdot L^3 \mu\text{m}$	0,05	IP65
1,0	8	60	Yes	0,05 μm	$0,2 + 3 \cdot L^3 \mu\text{m}$	0,05	IP65
0,85	8	60	Yes	0,05 μm	$0,2 + 3 \cdot L^3 \mu\text{m}$	0,05	IP50
0,85	8	60	Yes	0,05 μm	$0,2 + 3 \cdot L^3 \mu\text{m}$	0,05	IP50
2,0	8	60	Yes	0,05 μm	$1 + 4 \cdot L \mu\text{m}$ BPX: $0,6 + 0,8 \cdot L \mu\text{m}$	0,05	IP65
2,0	8	60	Yes	0,05 μm	$1 + 4 \cdot L \mu\text{m}$ BPX: $0,6 + 0,8 \cdot L \mu\text{m}$	0,05	IP65
1,0	8	60	Yes	0,05 μm	$1 + 4 \cdot L \mu\text{m}$ BPX: $0,6 + 0,8 \cdot L \mu\text{m}$	0,05	IP50
1,0	8	60	Yes	0,05 μm	$1 + 4 \cdot L \mu\text{m}$ BPX: $0,6 + 0,8 \cdot L \mu\text{m}$	0,05	IP50











USB, DC, Wireless Probes

							
			Measuring range, mm	Max. plunger travel, mm	Cable output	Bolt retraction	Sealing bellows
	03230500	GTL 21 W	± 2 mm	4,3	Without cable	Mechanical	Viton
	03230502	GT61 W	± 5 mm	10,3	Without cable	Mechanical	Viton
	03230501	GTL 212 W	± 1,5 mm	4,3	Without cable	Pressure (bolt activation), below spring (bolt retraction)	Viton
	03230503	GT 612 W	± 5 mm	10,3	Without cable	Pressure (bolt activation), below spring (bolt retraction)	Viton
	03230201	GTL 22 USB	± 2 mm	4,3	Radial	Mechanical	Viton
	03230200	GTL 21 USB	± 2 mm	4,3	Axial	Mechanical	Viton
	03230204	GT 61 USB	± 5 mm	10,3	Axial	Mechanical	Viton
	03230205	GT 62 USB	± 5 mm	10,3	Radial	Mechanical / vacuum	Viton
	03230202	GTL 222 USB	± 1,5 mm	3,1	Radial	Pressure (bolt activation), below spring (bolt retraction)	Viton
	03230058	GTL 22 DC	± 2 mm	4,3	Radial	Mechanical / vacuum	Viton
	03230059	GTL 21 DC	± 2 mm	4,3	Axial	Mechanical	Viton
	03230087	GT 62 DC	± 5 mm	10,3	Radial	Mechanical / vacuum	Viton
	03230086	GT 61 DC	± 5 mm	10,3	Axial	Mechanical	Viton
	03230085	GT 44 DC	± 1 mm	2,1	Radial	Mechanical / vacuum	Viton
	03230081	GT 31 DC	± 0,3 mm	0,7	Angled	Without retraction	Without bellows













* Nominal value of the measuring force at electrical zero, max. deviation $\pm 25\%$

** For an amplitude of 10% to the last value of the measuring range



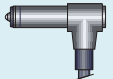

 Nominal measuring force*, N	 Mobile weight, g	 Max. mechanical frequency limit**, (Hz)	 Partially removable	 Repeatability, μm	 Maximum permissible error, μm (L in mm)	 Hysteresis, μm	 Level of protection (IP XX), as per IEC 60529
0,63	6	60	No	0,10 μm	$0,4 + 0,8 \cdot L \mu\text{m}$	0,5	IP54
0,9	8	60	No	0,24 μm	$0,8 + 0,8 \cdot L \mu\text{m}$	0,5	IP54
1,2	6	60	No	0,10 μm	$0,4 + 0,8 \cdot L \mu\text{m}$	0,5	IP54
2,0	8	60	No	0,24 μm	$0,8 + 0,8 \cdot L \mu\text{m}$	0,5	IP54
0,63	6	60	No	0,1 μm	$0,4 + 0,8 \cdot L \mu\text{m}$	0,5	IP65
0,63	6	60	No	0,1 μm	$0,4 + 0,8 \cdot L \mu\text{m}$	0,5	IP65
0,90	8	60	No	0,24 μm	$0,8 + 0,8 \cdot L \mu\text{m}$	0,5	IP65
0,90	8	60	No	0,24 μm	$0,8 + 0,8 \cdot L \mu\text{m}$	0,5	IP65
1,2	6	60	No	0,1 μm	$0,4 + 0,8 \cdot L \mu\text{m}$	0,5	IP64
0,63	6	60	Yes	0,1 μm	$0,2 + 3,5 \cdot L^2 \mu\text{m}$		IP65
0,63	6	60	Yes	0,1 μm	$0,2 + 3,5 \cdot L^2 \mu\text{m}$		IP65
0,9	8	60	No	0,1 μm	$1 + 4 \cdot L \mu\text{m}$		IP65
0,9	8	60	Yes	0,1 μm	$1 + 4 \cdot L \mu\text{m}$		IP65
0,4	2	60	No	0,1 μm	$0,2 + 5 \cdot L^2 \mu\text{m}$		IP65
0,1	12	25	No	0,1 μm	$0,2 + 50 \cdot L^2 \mu\text{m}$		IP50



Probes with Axial Movement, $\varnothing 8$ mm

							
			Measuring range, mm	Measuring bolt travel, mm	Cable output	Bolt retraction	Sealing bellows
	03230001	GT 41	$\pm 0,3$ mm	0,7	Axial	None	Nitrile
	03230002	GT 42	$\pm 0,3$ mm	0,7	Radial	Vacuum	Nitrile
	03230035	GT 43	± 1 mm	2,1	Axial	Mechanical	Viton
	03230017	GT 44	± 1 mm	2,1	Radial	Vacuum	Viton

Unbranded Axial Probes with Measuring Bolt Mounted on a Ball-bearing

	96410012	410	± 1 mm	2,5	Axial and radial	Mechanical	Nitrile
	96160013	160	± 1 mm	3,3	Axial	Mechanical	Viton
	96430029	430	$\pm 0,5$ mm	1,25	Axial	Mechanical	Nitrile
	96441041	451	$\pm 0,5$ mm	2,10	Radial	Mechanical	Nitrile



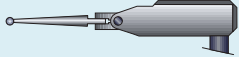





Probe with Inclinable Lever

	03210802	GT 31	$\pm 0,3$ mm	0,7	Angled	Without	Without bellows
---	----------	-------	--------------	-----	--------	---------	-----------------



* Nominal value of the measuring force at electrical zero, max. deviation $\pm 25\%$

** For an amplitude of 10 % to the last value of the measuring range

 Nominal measuring force*, N	 Mobile weight, g	 Max. mechanical frequency limit**, (Hz)	 Partially removable	 Repeatability, μm	 Max. permissible error for deviations in linearity, μm (L en mm)	 Hysteresis, μm	 Level of protection (IP XX), as per IEC 60529
0,63	2	60	No	0,01 μm	$0,2 + 5 \cdot L^2 \mu\text{m}$	0,01	IP65
0,63	2	60	No	0,01 μm	$0,2 + 5 \cdot L^2 \mu\text{m}$	0,01	IP65
0,4	2	60	No	0,1 μm	$0,2 + 5 \cdot L^2 \mu\text{m}$	0,15	IP65
0,4	2	60	No	0,1 μm	$0,2 + 5 \cdot L^2 \mu\text{m}$	0,15	IP65

0,60	3,1	60	No	0,1 μm	0,2 % (for a measuring span of ± 1 mm) μm		IP62
0,60	2,5	60	No	0,1 μm	0,2 % (for a measuring span of ± 1 mm) μm		IP62
0,75	1,9	60	No	0,2 μm	0,2 % (for a measuring span of $\pm 0,5$ mm) μm		IP62
0,60	3,0	60	No	0,1 μm	0,2 % (for a measuring span of $\pm 0,5$ mm) μm		IP62

0,1	12	25	No	0,1 μm	$0,2 + 50 \cdot L^2 \mu\text{m}$	0,25	IP40
-----	----	----	----	-------------------	----------------------------------	------	------











Universal FMS Probes

			 Measuring range, mm	 Measuring bolt travel, mm	 Cable output	 Bolt retraction	 Sealing bellows
	03230019	FMS 100	± 2 mm	5,8	Parallel	Retraction by air pressure (optional)	Without bellows
	03230049	FMS 130	± 2,9 mm	5,8	Parallel	Retraction by air pressure (optional)	Without bellows
	03230028	FMS 102	± 2 mm	5,8	Parallel	Retraction by air pressure (optional)	Without bellows
	03230050	FMS 132	± 2,9 mm	5,8	Parallel	Retraction by air pressure (optional)	Without bellows
	03230037	FMS100-P	± 2 mm	5,8	Parallel	Retraction by air pressure (optional)	Without bellows
	03230051	FMS130-P	± 2,9 mm	5,8	Parallel	Retraction by air pressure (optional)	Without bellows
	03230038	FMS102-P	± 2 mm	5,8	Angled	Retraction through air pressure (optional)	Without bellows
	03230052	FMS132-P	± 2,9 mm	5,8	Angled	Retraction through air pressure (optional)	Without bellows



* Nominal value of the measuring force at electrical zero, max. deviation $\pm 25\%$

** For an amplitude of 10% to the last value of the measuring range

 Nominal measuring force*, N	 Mobile weight, g	 Max. mechanical frequency limit**, Hz	 Partially removable	 Repeatability, μm	 Max. permissible error for deviation in linearity, μm (L in mm)	 Hysteresis, μm	 Protection level (IP XX), as per IEC 60529
2	110	25	Yes	0,5 μm	0,2 + 3 · L ³ μm	0,5	IP50
2	110	25	Yes	0,5 μm	0,2 + 3 · L ³ μm	0,5	IP50
2	110	25	Yes	0,5 μm	0,2 + 3 · L ³ μm	0,5	IP50
2	110	25	Yes	0,5 μm	0,2 + 3 · L ³ μm	0,5	IP50
2	110	25	Yes	0,5 μm	0,2 + 3 · L ³ μm	0,5	IP54
2	110	25	Yes	0,5 μm	0,2 + 3 · L ³ μm	0,5	IP54
2	110	25	Yes	0,5 μm	0,2 + 3 · L ³ μm	0,5	IP54
2	110	25	Yes	0,5 μm	0,2 + 3 · L ³ μm	0,5	IP54



Standard Probes, ± 1 mm, 4,3 mm Travel (GT21)

Universal probes for standard and continuous use applications.

- 8 mm diameter probe housing. Can be clamped over its entire length.
- Measuring bolt mounted on a ball bearing.
- Both the probe housing and ball-bearing guide are separate from one another, so that the measuring bolt moves easily even if the probe is not clamped appropriately.
- Degree of protection IP65 according to IEC 60529.
- Wide range of accessories including measuring inserts, spring sets, etc.
- LVDT probes compatible with measuring equipment from other makers available on request.



GT21

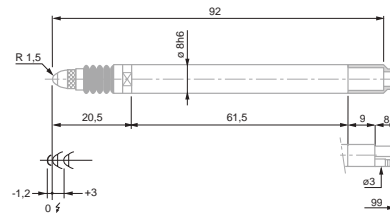

GT 21

No	=	Measuring range, mm	Nominal measuring force*, N	Measuring bolt retraction	Sealing bellows
03210904	GT 21	± 1	0,63	Mechanical	Nitrile
03210905	GT 21	± 1	1,00	Mechanical	Nitrile
03210906	GT 21	± 1	1,60	Mechanical	Nitrile
03210907	GT 21	± 1	2,50	Mechanical	Nitrile
03210908	GT 21	± 1	4,00	Mechanical	Nitrile

	=	Measuring bolt travel, mm	Max. permissible error for deviations in linearity, µm (L in mm)	Repeatability, µm	Hysteresis, µm	Setting of the lower bolt stop***, mm (factory setting)	Cable output	Data Sheet No.
GT 21	4,3	0,2 + 3 · L ³	0,01	0,02	-2,2 to 0,1 (factory setting -1,2)	Axial	03200249	

* Electrical zero (N) ± 25 % deviation limit. Valid in vertical mounting position, measuring bolt lowered and in static measuring.

** For an amplitude of 10 % to the last value of the measuring range.

*** Distance from electrical zero.



DIN 32876 Part 1



See table



Nickel-plated housing. Stainless steel measuring bolt, hardened. Nitrile sealing bellows = resistant elastomer



Fixing shank Ø 8 mm. Measuring bolt guided on ball-bearing. Distance from electrical zero of both stops is either adjustable (downward) or depending on the position of the lower stop (upward). Interchangeable inserts. M2,5 thread. Carbide ball tip Ø 3 mm. 2 m long cable. 5-pin DIN 45322 connector.



Supply frequency: 13 kHz (± 5 %). Max mechanical frequency** 60 Hz.



0,15 µm/°C



20 ± 0,5°C



-10°C to 65°C



80 %



Protection level IP65 (IEC 60529)



Mobile weight: 6 g



Transport packaging



Identification number



Inspection report with a declaration of conformity



Standard Probes, ± 1 mm, 4,3 mm Travel (GT22)

Universal probes for common but constraining applications.

- 8 mm diameter probe housing. Can be clamped over its entire length.
- Measuring bolt mounted on a ball bearing.
- Both the probe housing and ball-bearing guide are separate from one another, so that the measuring bolt moves easily even if the probe is not clamped appropriately.
- Degree of protection IP65 according to IEC 60529.
- Wide range of accessories including measuring inserts, spring sets, etc.
- LVDT probes compatible with measuring equipment from other makers available on request.

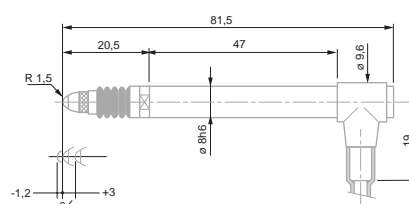

GT 22

GT 22



DIN 32876 Part 1



See table



Nickel-plated housing. Stainless steel measuring bolt, hardened. Nitrile sealing bellows = resistant elastomer



Fixing shank Ø 8 mm. Measuring bolt guided on ball-bearing. Distance from electrical zero of both stops is either adjustable (downward) or depending on the position of the lower stop (upward). Interchangeable inserts. M2,5 thread. Carbide ball tip Ø 3 mm. 2 m long cable. 5-pin DIN 45322 connector.



Supply frequency: 13 kHz (± 5 %). Max mechanical frequency** 60 Hz.



0,15 µm/°C



20 ± 0,5°C



-10°C to 65°C



80 %



Protection level IP65 (IEC 60529)



Mobile weight: 6 g



Transport packaging



Identification number



Inspection report with a declaration of conformity

		Measuring range, mm	Nominal measuring force*, N	Measuring bolt retraction	Sealing bellows
03210924	GT 22	± 1	0,63	Mechanical or vacuum	Nitrile
03210921	GT 22	± 1	0,16	Mechanical or vacuum	Nitrile
03210922	GT 22	± 1	0,25	Mechanical or vacuum	Nitrile
03210923	GT 22	± 1	0,40	Mechanical or vacuum	Nitrile
03210925	GT 22	± 1	1,00	Mechanical	Nitrile
03210926	GT 22	± 1	1,60	Mechanical	Nitrile
03210927	GT 22	± 1	2,50	Mechanical	Nitrile
03210928	GT 22	± 1	4,00	Mechanical	Nitrile

	Measuring travel, mm	Max. permissible error for deviations in linearity, µm (L in mm)	Repeatability, µm	Hysteresis, µm	Setting of the lower bolt stop***, mm (factory setting)	Cable output	Data Sheet No.
GT 22	4,3	0,2 + 3 · L ³	0,01	0,02	-2,2 to 0,1 (factory setting -1,2)	Radial	03200250

* Electrical zero (N) ± 25 % deviation limit. Valid in vertical mounting position, measuring bolt lowered and in static measuring.

** For an amplitude of 10 % to the last value of the measuring range.

*** Distance from electrical zero.



Standard Probes ± 2 mm, 4,3mm Bolt Travel, Linear Travel

Universal probes for standard and continual usage applications.

- Probe housing Ø 8 mm with possibility of clamping over its entire length.
- Measuring bolt mounted on a ball bearing.
- Both the probe housing and ball-bearing guide are separate from one another, so that the measuring bolt moves easily even if the probe is not clamped appropriately.
- Degree of protection IP65 according to IEC 60529.
- Wide range of accessories including measuring inserts, spring sets, etc.
- LVDT probes compatible with measuring equipment from other makers available on request.

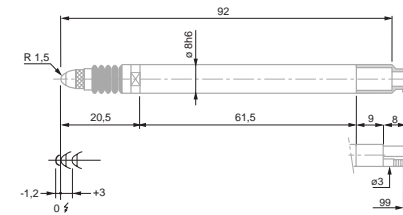

GTL 21
GTL 211

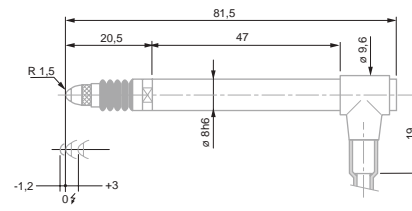

GTL 22



GTL 21
GTL 211



GTL 22

No	=	Measuring range, mm	Nominal measuring force*, N	Measuring bolt retraction	Sealing bellows
03230057	GTL 21	± 2	0,63	Mechanical	Viton
03230072	GTL 211	± 2	0,63	Vacuum	Viton
03230056	GTL 22	± 2	0,63	Vacuum	Viton

	Measuring bolt travel, mm	Max. permissible error for deviation in linearity, µm (L in mm)	Repeatability, µm	Hysteresis, µm	Setting of measuring bolt lower stop***, mm (factory setting)	Cable output	Data Sheet No.
GTL 21	4,3	0,2 + 2,4 · L ² (BPX: 0,2 + 0,8 · L)	0,01	0,02	-2,2 to 0,1 (factory setting -1,2)	Axial	03200391
GTL 211	4,3	0,2 + 2,4 · L ² (BPX: 0,2 + 0,8 · L)	0,01	0,02	-2,2 to 0,1 (factory setting -1,2)	Axial	03200435
GTL 22	4,3	0,2 + 2,4 · L ² (BPX: 0,2 + 0,8 · L)	0,01	0,02	-2,2 to 0,1 (factory setting -1,2)	Radial	03200392

* Electrical zero (N) ± 25 % deviation limit. Valid in vertical mounting position, measuring bolt lowered and in static measuring.

** For an amplitude of 10 % to the last value of the measuring range.

*** Distance from electrical zero.



DIN 32876 Part 1



See table



Nickel-plated housing, Stainless steel measuring bolt, hardened. Viton sealing bellows = highly resistant fluor elastomer



Fixing shank Ø 8 mm. Measuring bolt guided on ball-bearing. Distance from electrical zero of both stops is either adjustable (downward) or depending on the position of the lower stop (upward). Interchangeable inserts. M2,5 thread. Carbide ball tip Ø 3 mm. 2 m long cable, 5-pin DIN 45322 connector.



Supply frequency: 13 kHz (± 5 %) Max. mechanical frequency** 60 Hz.



0,2 µm/°C



20 ± 0,5°C



-10°C to 65°C



80 %



Protection level IP65 (IEC 60529)



Mobile weight: 6 g



Transport packaging



Identification number



Inspection report with a declaration of conformity



Standard Probes, ± 2 mm, 10,3 mm Travel, with Long Retraction Travel

Universal inductive probes for various applications, especially for use with multi-gauging inspection fixtures.

- Long retraction travel to prevent the probe from being damaged.
- Protection level IP65 as per IEC 60529.
- Large choice of accessories: measuring inserts, spring sets, etc.
- LVDT probes compatible with measuring equipment from other suppliers also available on request.



DIN 32876 Part 1



See table



Nickel-plated housing. Stainless steel measuring bolt, hardened. Viton bellows = high-resistance fluor elastomer



Fixing shank Ø 8 mm. Measuring bolt guided on ball-bearing. Distance from electrical zero of both stops is either adjustable (downward) or depending on the position of the lower stop (upward). Interchangeable inserts. M2,5 thread. Carbide ball tip Ø 3 mm. 2 m long cable. 5-pin DIN 45322 connector.



Supply frequency: 13 kHz (± 5 %) Max. mechanical frequency** 60 Hz.



0,15 µm/°C



20 ± 0,5°C



-10°C to 65°C



80 %



Protection level IP65 (IEC 60529)



Mobile weight: 8 g



Transport packaging



Identification number



Inspection report with a declaration of conformity



GT 27



GT 271



GT 28

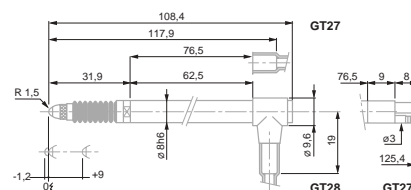

GT 27/ 28
GT 271

No	=	Table	Hand	Lightning bolt	Sealing bellows
		Measuring range, mm	Nominal measuring force*, N	Measuring bolt retraction	
03230027	GT 27	± 2	0,63	Mechanical	Viton
03230073	GT 271	± 2	0,63	Mechanical / vacuum	Viton
03230026	GT 28	± 2	0,63	Mechanical / vacuum	Viton

=	Table	0/3	Up/Down	Hysteresis	A	Lightning bolt	Warning
Measuring bolt travel, mm	Max. permissible error for deviations in linearity, µm (L in mm)	Repeatability, µm	Hysteresis, µm	Setting of measuring bolt lower stop***, mm (factory setting)	Cable output	Data Sheet No.	
GT 27	10,3	0,2 + 3 · L ³	0,05	0,05	-2,2 to 0,1 (factory setting -1,2)	Axial	03200251
GT 271	10,3	0,2 + 3 · L ³	0,05	0,05	-2,2 to 0,1 (factory setting -1,2)	Axial	03200436
GT 28	10,3	0,2 + 3 · L ³	0,05	0,05	-2,2 to 0,1 (factory setting -1,2)	Radial	03200252

* Electrical zero (N) ± 25 % deviation limit. Valid in vertical mounting position, measuring bolt lowered and in static measuring.

** For an amplitude of 10 % to the last value of the measuring range.

*** Distance from electrical zero



Standard Probes ± 5 mm, 10,3 mm Bolt Travel, Extended Range

- Designed for long measuring travels and low resolution of values
- Specially suited for use on multigauging inspection fixtures.
- Correction factor applied to get the true value is 2,5x (10x for the S probe version).
- Protection level IP 65 as per IEC 60529.
- Large choice of accessories: Measuring inserts, spring sets, etc.
- LVDT probes compatible with measuring equipment from other suppliers also available on request.



GT 61



GT 62

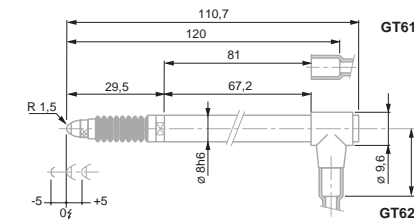

GT 61 / GT 62

		Measuring range, mm	Nominal measuring force*, N	Measuring bolt retraction	Sealing bellows
03230041	GT 61	± 5	0,90	Mechanical	Viton
03230042	GT 62	± 5	0,90	Mechanical / vacuum	Viton

Measuring bolt travel, mm	Max. permissible error for deviations in linearity, µm (L in mm)	Repeatability, µm	Hysteresis, µm	Measuring bolt***, mm (factory setting)	Cable output	Data Sheet No.	
GT 61	10,3	1 + 4 · L (BPX: 0,2 + 0,8 · L)	0,05	0,05	Lower - 5,1 upper + 5,2 (factory setting -5)	Axial	03200294
GT 62	10,3	1 + 4 · L (BPX: 0,2 + 0,8 · L)	0,05	0,05	Lower - 5,1 upper + 5,2 (factory setting -5)	Radial	03200295

* Electrical zero (N) ± 25 % deviation limit. Valid in vertical mounting position, measuring bolt lowered and in static measuring.
 ** For an amplitude of 10 % to the last value of the measuring range.
 *** Distance from electrical zero.

- DIN 32876 Part 1
- See table
- Nickel-plated housing, Stainless steel measuring bolt, hardened. Viton bellows = highly resistant fluoroe-lastomer
- Fixing shank Ø 8 mm. Measuring bolt guided on ball-bearing. Distance from electrical zero of both stops is either adjustable (downward) or depending on the position of the lower stop (upward). Interchangeable inserts. M2,5 thread. Carbide ball tip Ø 3 mm. 2 m long cable, 5-pin DIN 45322 connector.
- Supply frequency: 13 kHz (± 5 %) Max. mechanical frequency** 60 Hz.
- 0,09 µm/°C
- 20 ± 0,5°C
- 10°C to 65°C
- 80 %
- Protection level IP65 (IEC 60529)
- Mobile weight: 8 g
- Transport packaging
- Identification number
- Inspection report with a declaration of conformity



GT 21 HP High Precision Probes, ± 0,2 mm, 4,3 mm Travel

- Universal probe for common and continuous use applications.
- Very high precision probe suited for the measurement of gauge blocks.
- 8 mm diameter probe housing. Can be clamped over its entire length.
- Measuring bolt mounted on a ball bearing.
- Both the probe housing and ball-bearing guide are separate from one another, so that the measuring bolt moves easily even if the probe is not clamped appropriately.
- Level of protection IP65 according to IEC 60529.
- Wide range of accessories including measuring inserts, spring sets, etc.
- LVDT probes compatible with measuring equipment from other makers available on request.



GT 21 HP

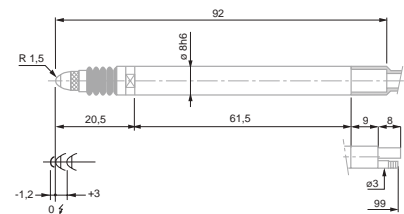

GT 21 HP

- DIN 32876 Part 1
- See table
- Nickel-plated housing. Stainless steel measuring bolt, hardened. Nitrile sealing bellow = resistant elastomer
- Fixing shank Ø 8 mm. Measuring bolt guided on ball-bearing. Distance from electrical zero of both stops is either adjustable (downward) or depending on the position of the lower stop (upward). Interchangeable inserts. M2,5 thread. Carbide ball tip Ø 3 mm. 2 m long cable. 5-pin DIN 45322 connector.
- Supply frequency: 13 kHz (± 5 %) Max. mechanical frequency** 60 Hz.
- 0,15 µm/°C
- 20 ± 0,5°C
- 10°C to 40°C
- 80 %
- Protection level IP65 (IEC 60529)
- Mobile weight: 6 g
- Transport packaging
- Identification number
- Inspection report with a declaration of conformity

03230036	GT 21 HP	Measuring range, mm	Measuring force, nominal*, N	Bolt retraction	Sealing bellows
		± 0,2	0,63	Mechanical	Nitrile

GT 21 HP	Measuring bolt travel, mm	Max. permissible error for deviations in linearity, µm (L in mm)	Repeatability, µm	Hysteresis, µm	Setting of lower stop of measuring bolt***, mm (factory setting)	Cable output	Data Sheet No.
	4,3	07 + 0,4 · L	0,01	0,01	-2,2 to +0,1 (factory setting -1,2)	Axial	03200264

* Electrical zero (N) ± 25 % deviation limit. Valid in vertical mounting position, measuring bolt lowered and in static measuring.
 ** For an amplitude of 10 % to the last value of the measuring range.
 *** Distance from electrical zero.



GT 22 HP High Precision Probe, ± 0,2 mm, 4,3 mm Travel

Universal probe for standard and continuous use applications.

- Very high precision probe suitable for the measurement of gauge blocks.
- 8 mm diameter probe housing. Can be clamped over its entire length.
- Measuring bolt mounted on a ball bearing.
- Both the probe housing and ball-bearing guide are separate from one another, so that the measuring bolt moves easily even if the probe is not clamped appropriately.
- Level of protection IP65 according to IEC 60529.
- Wide range of accessories including measuring inserts, spring sets, etc.
- LVDT probes compatible with measuring equipment from other makers available on request.



GT 22 HP

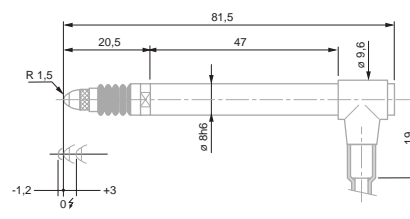

GT 22 HP

No	=	Measuring range, mm	Measuring force, nominal*, N	Bolt retraction	Sealing bellows
03230021	GT 22 HP	± 0,2	0,63	Mechanical or vacuum	Nitrile

	=	Measuring travel, mm	Max. permissible error for deviations in linearity, µm (L in mm)	Repeatability, µm	Hysteresis, µm	Setting of lower stop of the measuring bolt***, mm (factory setting)	Cable output	Data Sheet No.
GT 22 HP	4,3	0,07 + 0,4 · L	0,01	0,01	-2,2 to +0,1 (usine -1,2)	Radial	03200265	

* Electrical zero (N) ± 25 % deviation limit. Valid in vertical mounting position, measuring bolt lowered and in static measuring.

** For an amplitude of 10 % to the last value of the measuring range.

*** Distance from electrical zero.



DIN 32876 Part 1



See table



Nickel-plated housing. Stainless steel measuring bolt, hardened. Nitrile sealing bellows = resistant elastomer



Fixing shank Ø 8 mm. Measuring bolt guided on ball-bearing. Distance from electrical zero of both stops is either adjustable (downward) or depending on the position of the lower stop (upward). Interchangeable inserts. M2,5 thread. Carbide ball tip Ø 3 mm. 2 m long cable. 5-pin DIN 45322 connector.



Supply frequency: 13 kHz (± 5 %) Max. mechanical frequency*** 60 Hz.



0,15 µm/°C



20 ± 0,5°C



10°C to 40°C



80 %



Protection level IP65 (IEC 60529)



Mobile weight: 6 g



Transport packaging



Identification number



Inspection report with a declaration of conformity



Pneumatic Probes ± 1,5 mm, 3,2 mm Bolt Travel, Linear

Probes for use with measuring fixtures or inspection machines integrating semi-automated or automated measuring routines.

- 8 mm diameter probe housing. Can be clamped over its entire length.
- Measuring bolt mounted on a ball bearing.
- Both the probe housing and ball-bearing guide are separate from one another, so that the measuring bolt moves easily even if the probe is not clamped appropriately.
- Degree of protection IP65 according to IEC 60529.
- Wide range of accessories including measuring inserts, etc.
- LVDT probes compatible with measuring equipment from other makers available on request.

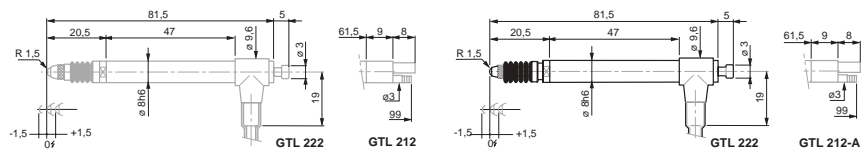

GTL 212 / GTL 222

GTL 212-A / GTL 222-A



GTL 222



GTL 212



GTL 212-A



GTL 222-A



DIN 32876 Part 1



See table



Nickel-plated housing. Stainless steel measuring bolt, hardened. Viton sealing bellow = highly resistant fluoroelelastomer



Fixing shank Ø 8 mm. Measuring bolt guided on ball-bearing. Distance from electrical zero of both stops is either adjustable (downward) or depending on the position of the lower stop (upward). Interchangeable inserts. M2,5 thread. Carbide ball tip Ø 3 mm. 2 m long cable. 5-pin DIN 45322 connector.



Supply frequency: 13 kHz (± 5 %) Max. mechanical frequency** 60 Hz.



0,2 µm/°C



20 ± 0,5°C



-10°C to 65°C



80 %



Protection level: IP65 (IEC 60529) or IP50 for GTL 212-A and GTL 222-A



Mobile weight: 6 g



Transport packaging



Identification number



Inspection report with a declaration of conformity

No	Measuring bolt travel, mm	Measuring range, mm	Measuring force, nominal*, N	Measuring bolt retraction	Sealing bellows	Nominal/Maximal pressure, bar
03230060	GTL 212	± 1,5	1,2	Pressure (bolt activation), spring (bolt retraction)	Viton	0,7 / max 1,0
03230054	GTL 222	± 1,5	1,2	Pressure (bolt activation), spring (bolt retraction)	Viton	0,7 / max 1,0
03230067	GTL 212-A	± 1,5	0,2	Pressure (bolt activation), spring (bolt retraction)	Without bellows	0,25 / max 6,0
03230063	GT 222-A	± 1,5	0,2	Pressure (bolt activation), spring (bolt retraction)	Without bellows	0,25 / max 6,0

Measuring bolt travel, mm	Max. permissible error for deviations in linearity, µm (L in mm)	Repeatability, µm	Hysteresis, µm	Cable output	Data Sheet No.
GTL 212	0,2 + 2,4 · L ² (BPX: 0,2 + 0,8 · L)	0,015	0,02	Axial	03200413
GTL 222	0,2 + 2,4 · L ² (BPX: 0,2 + 0,8 · L)	0,015	0,02	Radial	03200393
GTL 212-A	0,2 + 2,4 · L ² (BPX: 0,2 + 0,8 · L)	0,015	0,02	Axial	03200430
GT 222-A	0,2 + 2,4 · L ² (BPX: 0,2 + 0,8 · L)	0,015	0,02	Radial	03200422

* Electrical zero (N) ± 25 % deviation limit. Valid in vertical mounting position, measuring bolt lowered and in static measuring.

** For an amplitude of 10 % to the last value of the measuring range.



Pneumatic Probes ± 2 mm, 10,3 mm Bolt Travel, with Long Retraction Travel

These probes are intended for use with measuring fixtures or machines integrating automated and semi-automated measuring routines.

- 8 mm diameter probe housing. Can be clamped over its entire length.
- Measuring bolt mounted on a ball bearing.
- Both the probe housing and ball-bearing guide are separate from one another, so that the measuring bolt moves easily even if the probe is not clamped appropriately.
- Degree of protection IP65 according to IEC 60529.
- Wide range of accessories including measuring inserts, etc.
- LVDT probes compatible with measuring equipment from other makers available on request.



GT 282-A

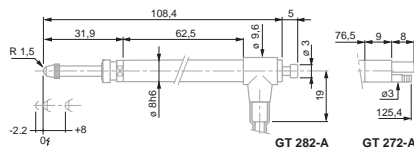

GT 282-A / GT 272-A

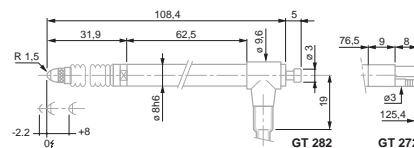

GT 282 / GT 272



GT 282



GT 272



GT 272-A

		Measuring range, mm	Measuring force, nominal*, N	Bolt retraction	Sealing bellows	Nominal/Maximal pressure, bar
03230061	GT 272	± 2	1,0	Pressure (bolt activation), spring (bolt retraction)	Viton	1,1 / max 1,5
03230053	GT 282	± 2	1,0	Pressure (bolt activation), spring (bolt retraction)	Viton	1,1 / max 1,5
03230068	GT 272-A	± 2	0,85	Pressure (bolt activation), spring (bolt retraction)	Without bellows	1,0 / max 6,0
03230069	GT 282-A	± 2	0,85	Pressure (bolt activation), spring (bolt retraction)	Without bellows	1,0 / max 6,0

	Measuring bolt travel, mm	Max. permissible error for deviations in linearity, µm (L in mm)	Repeatability, µm	Hysteresis, µm	Cable output	Data Sheet No.
GT 272	10,3	0,2 + 3 · L ³	0,05	0,05	Axial	03200414
GT 282	10,3	0,2 + 3 · L ³	0,05	0,05	Radial	03200390
GT 272-A	10,3	0,2 + 3 · L ³	0,05	0,05	Axial	03200431
GT 282-A	10,3	0,2 + 3 · L ³	0,05	0,05	Radial	03200432

* Electrical zero (N) ± 25 % deviation limit. Valid in vertical mounting position, measuring bolt lowered and in static measuring.

** For an amplitude of 10 % to the last value of the measuring range.



DIN 32876 Part 1



See table



Nickel-plated housing. Stainless steel measuring bolt, hardened. Viton sealing bellows = highly resistant fluoroelelastomer



Fixing shank Ø 8 mm. Measuring bolt guided on ball-bearing. Distance from electrical zero of both stops is either adjustable (downward) or depending on the position of the lower stop (upward). Interchangeable inserts. M2,5 thread. Carbide ball tip Ø 3 mm. 2 m long cable, 5-pin DIN 45322 connector.



Supply frequency: 13 kHz (± 5 %) Max. mechanical frequency** 60 Hz.



0,15 µm/°C



20 ± 0,5°C



-10°C to 65°C



80 %



Protection level: IP65 (IEC 60529), IP64 for GT 21 HP



Mobile weight: 8 g



Transport packaging



Identification number



Inspection report with a declaration of conformity



Pneumatic Probes ± 5 mm, 10,3 mm Bolt Travel, Long Travel

These probes are designed for use with measuring fixtures and machines with integrated automatic or semi-automatic measuring routines.

- Probes with long measuring travel and low resolution of values 8 mm dia. fixing shank.
- Suitable for multi-gauging inspection fixtures.
- Protection level IP65 ou IP50 as per IEC 60529.
- Wide range of accessories including measuring inserts, etc.
- LVDT probes compatible with measuring equipment from other suppliers available on request.



DIN 32876 Part 1



See table



Nickel-plated housing. Stainless steel measuring bolt, hardened. Viton sealing bellows = highly resistant fluoroelastomer



Fixing shank Ø 8 mm. Measuring bolt guided on ball-bearing. Distance from electrical zero of both stops is either adjustable (downward) or depending on the position of the lower stop (upward). Interchangeable inserts. M2,5 thread. Carbide ball tip Ø 3 mm. 2 m long cable. 5-pin DIN 45322 connector.



Supply frequency: 13 kHz (± 5 %) Max. mechanical frequency** 60 Hz.



0,09 µm/°C



20 ± 0,5°C



-10°C to 65°C



80 %



Protection level: IP65 (IEC 60529),



Mobile weight: 8 g



Transport packaging



Identification number



Inspection report with a declaration of conformity

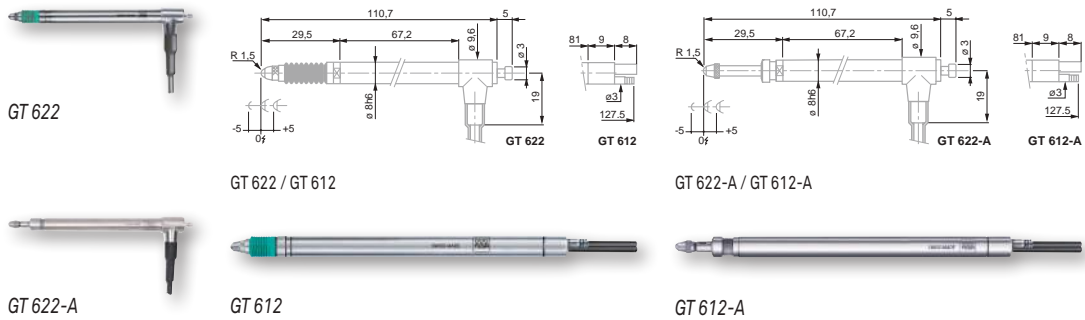

No	=	Measuring range, mm	Measuring force, nominal*, N	Bolt retraction	Sealing bellows	Nominal/Maximal pressure, bar
03230062	GT 612	± 5	2,0	Pressure (bolt activation), spring (bolt retraction)	Viton	1,1 / max 1,5
03230055	GT 622	± 5	2,0	Pressure (bolt activation), spring (bolt retraction)	Viton	1,1 / max 1,5
03230070	GT 612-A	± 5	1,0	Pressure (bolt activation), spring (bolt retraction)	Without bellows	1,0 / max 6,0
03230071	GT 622-A	± 5	1,0	Pressure (bolt activation), spring (bolt retraction)	Without bellows	1,0 / max 6,0

=	Measuring bolt travel, mm	Max. permissible error for deviations in linearity, µm (L in mm)	Repeatability, µm	Hysteresis, µm	Cable output	Data sheet No.
GT 612	10,3	1 + 4 · L (BPX: 0,6 + 0,8 · L)	0,05	0,05	Axial	03200415
GT 622	10,3	1 + 4 · L (BPX: 0,6 + 0,8 · L)	0,05	0,05	Radial	03200394
GT 612-A	10,3	1 + 4 · L (BPX: 0,6 + 0,8 · L)	0,05	0,05	Axial	03200433
GT 622-A	10,3	1 + 4 · L (BPX: 0,6 + 0,8 · L)	0,05	0,05	Radial	03200434

* Electrical zero (N) ± 25 % deviation limit. Valid in vertical mounting position, measuring bolt lowered and in static measuring.
** For an amplitude of 10 % to the last value of the measuring range.



Wireless Probe ± 2 mm

Probes developed for devices requiring a greater freedom of movement during the measurement or for parts with large dimensions.

Bidirectional and wireless communication synchronized with the TWIN-STATION Receiver.

- Resolution 0,1 μ m.
- Range of 8 m, depending on environment.
- TESA wireless communication protocol independent of WiFi or Bluetooth.
- Autonomy 40 hours (rechargeable battery).
- Mounting stem \varnothing 8 mm with clamping possible over entire length.
- Measuring bolt mounted on ball bearing.
- Ball bearing guide separated from mounting stem in order not to negatively influence the movement of the measuring bolt in the event of improper clamping of the probe body.
- Level of protection IP54 according to IEC 60529.
- Wide range of measurement inserts.
- Swiss made.
- The TWIN-STATION (part number 05030012) manages and synchronizes up to 8 wireless probes.
- Interface Software TIS included in delivery content of the TWIN-STATION (part number 05030012): display of measured values, possibility to indicate tolerances, simple functions +A, -A, +A+B, +A-B, and export of values as a .csv file.

Note: The sale is limited to EU countries, Switzerland, USA, Canada and China.



GTL 21 W

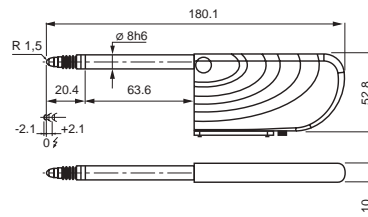

GTL 21 W

03230500	GTL 21 W	Measuring range, mm ± 2	Nominal measuring force*, N 0,63	Bolt retraction Mechanical	Sealing bellows Viton
OPTIONAL ACCESSORY: 05030012 TWIN Station Interface for wireless probes					

Max. plunger travel, mm	Maximum permissible error, μ m (L in mm)	Repeatability, μ m	Hysteresis, μ m	Setting of lower stop of the measuring bolt***, mm	Cable output	Data sheet No.	
GTL 21 W	4,3	0,4 + 0,8 · L	0,10	0,5	Fixed stops: lower -2,1 upper +2,1	Without cable	03200602

* Electrical zero (N) \pm 25 % deviation limit. Valid in vertical mounting position, measuring bolt lowered and in static measuring.
 ** For an amplitude of 10 % to the last value of the measuring range.
 *** Distance from electrical zero.

-
- DIN 32876 Part 1
- See table
- Nickel-plated housing
Stainless steel measuring bolt, hardened
Viton sealing bellows = highly resistant fluoroe-lastomer
- Fixing body nickel \varnothing 8 mm
Stainless steel measuring bolt, hardened and ball bearing guided
Fixed upper and lower stops
Interchangeable inserts
M2,5 thread
Carbide ball \varnothing 3 mm
Mini jack connector for charger.
- Mechanical max. frequency**: 60 Hz
Power supply: 100 \div 240 VAC, 50 \div 60 Hz; 240 mAh
Rechargeable battery: 3,7 V, min. 550 mAh or 800 mAh
Frequency band: 2,4 GHz Range: 8 m, depending on environment.
- $\pm 0,2$ μ m/ $^{\circ}$ C
- $20 \pm 0,5$ $^{\circ}$ C
- 10° C to 40° C
- 80 %
- Protection level IP54 (IEC 60529)
- GTL 21 W: 6g
- Transport packaging
- Identification number
- Inspection report with a declaration of conformity



Wireless Probe ± 5 mm, Large Measuring Range

Probes developed for devices requiring a greater freedom of movement during the measurement or for parts with large dimensions.

Bidirectional and wireless communication synchronized with the TWIN-STATION Receiver.

- Resolution 0,1 µm.
- Range of 8 m, depending on environment.
- TESA wireless communication protocol independent from WiFi or Bluetooth.
- Autonomy 40 hours (rechargeable battery).
- Mounting body Ø 8 mm with possibility of clamping over entire length.
- Measuring bolt mounted on ball bearing.
- Separate guide bearing on the mounting body in order not to negatively influence the movement of the measuring bolt in the event of improper clamping on the probe body.
- Level of protection IP54 according to IEC 60529.
- Wide range of measurement probes.
- Swiss made.
- The TWIN-STATION (part number 05030012) manages and synchronizes up to 8 wireless probes.
- Interface Software TIS included in supply content of the TWIN-STATION (part number 05030012): display of measured values, possibility to indicate tolerances, simple functions +A, -A, +A+B, +A-B, and export of values in a .csv file.

Note: The sale is limited to EU countries, Switzerland, USA, Canada and China.



DIN 32876 Part 1

See table

Nickel-plated housing
Stainless steel measuring bolt, hardened. Viton = highly resistant fluoroelelastomer

Fixing shank Ø 8 mm. Measuring bolt guided on ball-bearing. Distance from electrical zero of both stops is either adjustable (downward) or depending on the position of the lower stop (upward). Interchangeable inserts. M2,5 thread. Carbide ball tip Ø 3 mm. Connector Mini-jack for charger.

Mechanical max. frequency**: 60 Hz
Power supply: 100 ÷ 240 VAC, 50 ÷ 60 Hz; 240 mAh
Rechargeable battery: 3,7 V, min. 550 mAh or 800 mAh
Frequency band: 2,4 GHz
Range: 8 m, depending on environment.

± 0,2 µm/°C

20 ± 0,5°C

10°C to 40°C

80 %

Protection operating envelope IP54 (IEC 60529)

GT 61 W: 8 g

Transport packaging

Identification number

Inspection report with a declaration of conformity



GT 61 W

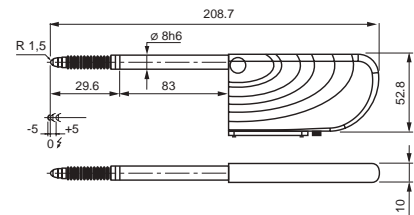

GT 61 W

No	=	Measuring range, mm	Nominal measuring force*, N	Bolt retraction	Sealing bellows
03230502	GT 61 W	± 5	0,9	Mechanical	Viton
OPTIONAL ACCESSORY:					
05030012	TWIN Station Interface for wireless probes				

	=	Max. bolt travel, mm	Maximum permissible error, µm (L in mm)	Repeatability, µm	Hysteresis, µm	Setting of lower stop of measuring bolt***, mm	Cable output	Data sheet No.
GT 61 W		10,3	0,8 + 0,8- L	0,24	0,5	Fixed stops lower -5 upper +5	Without cable	03200621

* Electrical zero (N) ± 25 % deviation limit. Valid in vertical mounting position, measuring bolt lowered and in static measuring.

** For an amplitude of 10 % to the last value of the measuring range.

*** Distance from electrical zero.



Wireless Pneumatic Probe $\pm 1,5$ mm

Probes developed for devices requiring a greater freedom of movement during the measurement or for parts with large dimensions.

Bidirectional and wireless communication synchronized with the TWIN-STATION Receiver.

- Resolution 0,1 μ m.
- Range of 8 m, depending on environment.
- TESA wireless communication protocol independent from WiFi or Bluetooth
- Autonomy 40 hours (rechargeable battery).
- Support structure \varnothing 8 mm with enhanced clamping over its entire length
- Measuring rod mounted on ball bearing.
- Separate guide bearing on the holding body in order not to negatively influence the movement of the measuring rod in the event of improper clamping of the probe beads.
- Level of protection IP54 according to IEC 60529.
- Wide range of measurement probes.
- Swiss made.
- The TWIN-STATION (part number 05030012) manages and synchronizes up to 8 wireless probes.
- Interface Software TIS included in delivery content of the TWIN-STATION (art. 05030012): display of measured values, possibility to indicate tolerances, simple functions +A, -A, +A+B, +A-B, and export of values in a .csv file.

Note: The sale is limited to EU countries, Switzerland, USA, Canada and China.



GTL 212 W

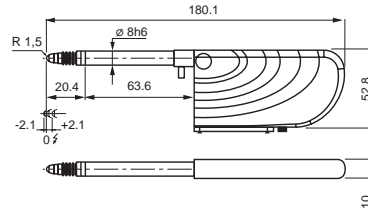

GTL 212 W

		Measuring range, mm	Nominal measuring force*, N	Bolt retraction	Sealing bellows	Nominal/maximal pressure, bar
03230501	GTL 212	$\pm 1,5$	1,2	Pressure (bolt activation), spring (bolt retraction)	Viton	0,7 / max. 1,0

OPTIONAL ACCESSORY:

05030012 TWIN Station Interface for wireless probes

	Max. measuring bolt travel, mm	Maximum permissible error, μ m (L in mm)	Repeatability, μ m	Hysteresis, μ m	Setting of lower stop of the measuring bolt***, mm	Cable output	Data sheet No.
GTL 212 W	4,3	0,4 + 0,8 · L	0,10	0,5	Fixed stops: lower -2,1 upper +2,1	Without cable	03200620

* Electrical zero (N) ± 25 % deviation limit. Valid in vertical mounting position, measuring bolt lowered and in static measuring.

** For an amplitude of 10 % to the last value of the measuring range.

*** Distance from electrical zero.



DIN 32876 Part 1



See table



Nickel-plated housing
Stainless steel measuring bolt, hardened
Viton sealing bellows = highly resistance fluororelastomer



Fixing body nickel \varnothing 8 mm
Stainless steel measuring bolt, hardened and ball bearing guided
Fixed upper and lower stops
Probe interchangeable
M2,5 thread
Carbide ball \varnothing 3 mm
Mini jack connector for charger.



Mechanical max. frequency**: 60 Hz
Power supply: 100 \div 240 VAC, 50 \div 60 Hz; 240 mAh
Rechargeable battery: 3,7 V, min. 550 mAh or 800 mAh
Frequency band: 2,4 GHz
Range: 8 m, depending on environment.



$\pm 0,2$ μ m/ $^{\circ}$ C



$20 \pm 0,5$ $^{\circ}$ C



10 $^{\circ}$ C to 40 $^{\circ}$ C



80 %



Protection IP54 (IEC 60529)



GTL 212 W: 6g



Transport packaging



Identification number



Inspection report with a declaration of conformity



Wireless Pneumatic Probe ± 5 mm, Large Measuring Range

Probes developed for devices requiring a greater freedom of movement during the measurement or for pieces with large dimensions.

Bidirectional and wireless communication synchronized with the TWIN-STATION Receiver.

- Resolution 0,1 µm.
- Range of 8 m, depending on environment.
- TESA wireless communication protocol independent from WiFi or Bluetooth.
- Autonomy 40 hours (rechargeable battery).
- Mounting body Ø 8 mm with enhanced clamping over its entire length.
- Measuring bolt mounted on ball bearing.
- Separate guide bearing on the holding body in order not to negatively influence the movement of the measuring bolt in the event of improper clamping on the probe body.
- Level of protection IP54 according to IEC 60529.
- Wide range of measurement probes.
- Swiss made.
- The TWIN-STATION (part number 05030012) manages and synchronizes up to 8 wireless probes.
- Interface Software TIS included in delivery content of the TWIN-STATION (art. 05030012): display of measured values, possibility to indicate tolerances, simple functions +A, -A, +A+B, +A-B, and export of values in a .csv file.

Note: The sale is limited to EU countries, Switzerland, USA, Canada and China.



GT 612 W

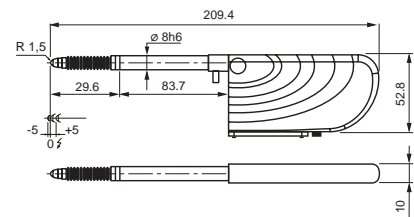

GT 612 W

- DIN 32876 Part 1
- See table
- Nickel-plated housing
Stainless steel measuring bolt, hardened
Viton sealing bellows = highly resistance fluororelastomer
- Fixing body nickel Ø 8 mm
Stainless steel measuring bolt, hardened and ball bearing guided
Fixed upper and lower stops
Probe interchangeable
M2, 5 thread
Carbide ball Ø 3 mm
Mini jack connector for charger
- Mechanical max. frequency**: 60 Hz
Power supply: 100 ÷ 240 VAC, 50 ÷ 60 Hz; 240 mAh
Rechargeable battery: 3,7 V, min. 550 mAh or 800 mAh
Frequency band: 2,4 GHz
Range: 8 m, depending on environment.
- Wireless transmission, TWIN-STATION Receiver (05030012)
- ± 0,2 µm/°C
- 20 ± 0,5°C
- 10°C to 40°C
- 80 %
- Protection level IP54 (IEC 60529)
- GT 612 W: 8 g
- Transport packaging
- Identification number
- Inspection report with a declaration of conformity

		Measuring range, mm	Nominal measuring force*, N	Bolt retraction	Sealing bellows	Nominal/maximal pressure, bar
03230503	GT 612 W	± 5	2,0	Pressure (bolt activation), spring (bolt retraction)	Viton	1,1 / max. 1,5

OPTIONAL ACCESSORY:
05030012 TWIN Station Interface for wireless probes

	Max. bolt travel, mm	Maximum permissible error (L in mm)	Repeatability, µm	Hysteresis, µm	Setting of lower stop of measuring bolt***, mm	Cable output	Data sheet No.
GT 612 W	10,3	0,8 + 0,8 · L	0,24	0,5	Fixed stops: lower -5 upper +5	Without cable	03200622

* Electrical zero (N) ± 25 % deviation limit. Valid in vertical mounting position, measuring bolt lowered and in static measuring.
** For an amplitude of 10 % to the last value of the measuring range.
*** Distance from electrical zero.



USB Probes ± 2 mm, 4,3 mm Range

Universal probes for applications aided by a USB connection.

- Probe mounting body Ø 8 mm with enhanced clamping over its entire length.
- Measuring bolt mounted on ball bearing.
- Separate guide bearing on the mounting body in order not to negatively influence the movement of the measuring bolt in the event of improper clamping of the probe beads.
- Level of protection IP65 according to IEC 60529.
- Wide range of measurement inserts.
- TSIP software interface included in supply 1 to 4 USB probes display.
- Possibility of indicating tolerances and simple functions + A, -A, + A + B + AB.
- To manage more than 4 probes USB, use the DataDirect (part number 04981001) or StatExpress software (part number 04981002), available as an option.



TSIP Software



GTL 21 USB

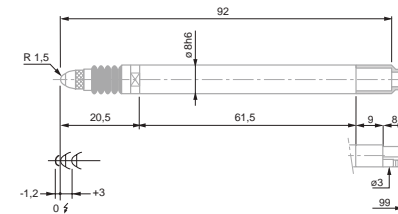

GTL 21 USB



GTL 22 USB

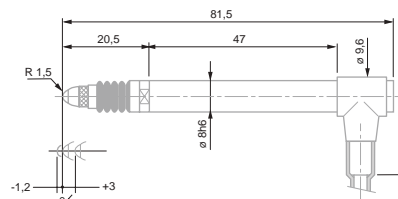

GTL 22 USB

			Measuring range, mm	Nominal measuring force*, N	Bolt retraction	Sealing bellows
03230200		GTL21 USB	± 2	0,63	Mechanical	Viton
03230201		GTL 22 USB	± 2	0,63	Mechanical/vacuum	Viton

	Measuring bolt travel, mm	Max. permissible error, µm (L in mm)	Repeatability, µm	Hysteresis, µm	Setting of lower stop of measuring bolt*** mm	Cable output	Data sheet No.	
GTL21 USB	4,3	0,4 + 0,8 · L	0,1	0,5	Fixed stops: lower -2,0 upper +2,0	Axial	03200587	
GTL 22 USB	4,3	0,4 + 0,8 · L	0,1	0,5	Fixed stops: lower -2,0 upper +2,0	Radial	03200588	

* Electrical zero (N) ± 25 % deviation limit. Valid in vertical mounting position, measuring bolt lowered and in static measuring.

** For an amplitude of 10 % to the last value of the measuring range.

*** Distance from electrical zero.



DIN 32876 Part 1



See table



Nickel-plated housing, Stainless steel measuring bolt, hardened. Viton sealing bellows = highly resistant fluoroelelastomer



Fixing body Ø 8 mm. Measuring bolt guided on ball bearing. Fixed upper and lower stops. Interchangeable inserts. M 2,5 thread. Carbide ball Ø 3 mm. Cable length: 2,9 m. USB Type A plug connector



Max. mechanical frequency** 60 Hz.
Consumption: 70 mAh, 5V
Normal measuring interval = 80ms (optimal accuracy)
Minimal measuring interval = 20ms (most rapid transfer of data)
Stabilisation time after switching power on = 12 min.



0,2 µm/°C



20 ± 0,5°C



10°C to 40°C



80 %



IP65 (IEC 60529)



Mobile weight: 6 g



Transport packaging



Identification number



Inspection report with a declaration of conformity



USB Pneumatic Probes ± 1,5 mm, 3,1 mm Bolt Travel

Universal probes for applications facilitated by a USB connection

- Mounting body Ø 8 mm with possibility of clamping over its entire length.
- Measuring rod mounted on ball bearing.
- Separate guide bearing on the holding body in order not to negatively influence the movement of the measuring bolt in the event of improper clamping of the probe beads.
- Level of protection IP65 or IP50 according to IEC 60529.
- Wide range of measurement inserts.
- TSIP software interface included in supply: display 1 to 4 USB probes. Possibility of indicating tolerances and simple functions + A, -A, + A + B + AB.
- To manage more than 4 probes USB, use the DataDirect (part number 04981001) or StatExpress software (part number 04981002), available as an option.



DIN 32876 Part 1



See table



Nickel-plated housing. Stainless steel measuring bolt, hardened. Viton sealing bellows = highly resistant fluoroe elastomer



Fixing shank Ø 8 mm. Measuring bolt on ball bearing guide. Fixed lower and upper stops. Interchangeable measuring insert. Thread M2,5. Carbide ball Ø 3 mm Cable length: 2,9 m USB type A connector



Max. mechanical frequency** 60 Hz.
Consumption: 70 mAh, 5V
Normal measuring interval = 80 ms (optimal accuracy)
Minimal measuring interval = 20 ms (most rapid transfer of data)
Stabilisation time after switching power on = 12 min.
Remark: Compressed air supply must be generated through a filter and precision regulator. The air should have a humidity of < 60 % and be filtered to < 0,5 µm.



0,2 µm/°C



20 ± 0,5°C



10°C to 40°C



80 %



IP65 (IEC 60529) or IP50 for GTL 222-A



Mobile weight: 6 g



Transport packaging



Identification number



Inspection report with a declaration of conformity



GTL 222 USB

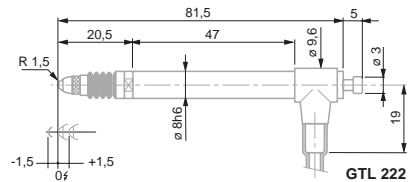

GTL 222 USB



TSIP Software

No	=	Table	Hand	Gear	Gear	Gear
03230202	GTL222 USB	Measuring range, mm	Nominal measuring force*, N	Bolt retraction	Sealing bellows	Nominal/Maximal Pressure, bar
		± 1,5	1,2	Pressure (bolt activation), spring (bolt retraction)	Viton	0,7 / max 1,0

=	Table	0.5	Hand	Hand	Gear	Warning
GTL222 USB	Measuring bolt travel, mm	Max. permissible error, µm (L in mm)	Repeatability, µm	Hysteresis, µm	Cable output	Data sheet No.
	3,1	0,4 + 0,8 · L	0,1	0,5	Radial	03200589

* Electrical zero (N) ± 25 % deviation limit. Valid in vertical mounting position, measuring bolt lowered and in static measuring.

** For an amplitude of 10 % to the last value of the measuring range.



USB Probes ± 5 mm, 10,3 mm Bolt Travel, Extended Measuring Range

USB universal probes for applications facilitated by a USB connection.

- Probes designed for long measuring travel and low resolution measurement values.
- Probe mounting body Ø 8 mm with possibility of clamping over its entire length.
- Measuring bolt mounted on ball bearing.
- Separate guide bearing on the holding body in order not to negatively influence the movement of the measuring bolt in the event of improper clamping of the probe beads.
- Level of protection IP65 according to IEC 60529.
- Wide range of measurement inserts.
- TSIP software interface included in supply 1 to 4 USB probes display. Possibility of indicating tolerances, simple functions + A, -A, + A + B + AB.
- To manage more than 4 USB probes, use the DataDirect (part number 04981001) or StatExpress software (part number 04981002), available as an option.



GT 61 USB

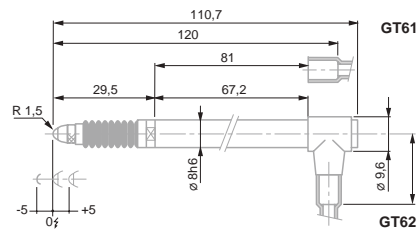

GT 61 USB / GT 62 USB



TSIP Software

No	=	Measuring range, mm	Nominal measuring force*, N	Bolt retraction	Sealing bellows
03230204	GT61 USB	± 5	0,90	Mechanical	Viton
03230205	GT62 USB	± 5	0,90	Mechanical/vacuum	Viton

=	Measuring bolt travel, mm	Max. permissible error, µm (L in mm)	Repeatability, µm	Hysteresis, µm	Settings of lower stop of bolt***, mm	Cable output	Data sheet No.
GT61 USB	10,3	0,8 + 0,8 · L	0,24	0,5	Fixed stops: lower -5,0 upper +5,0	Axial	03200591
GT62 USB	10,3	0,8 + 0,8 · L	0,24	0,5	Fixed stops: lower -5,0 upper +5,0	Radial	03200592

* Electrical zero (N) ± 25 % deviation limit. Valid in vertical mounting position, measuring bolt lowered and in static measuring.

** For an amplitude of 10 % to the last value of the measuring range.

*** Distance from electrical zero.



DIN 32876 Part 1



See table



Nickel-plated housing, Stainless steel measuring bolt, hardened. Viton sealing bellows = highly resistant fluor elastomer



Fixing shank Ø 8 mm. Measuring bolt guided on ball-bearing. Distance from electrical zero of both stops is either adjustable (downward) or depending on the position of the lower stop (upward). Interchangeable inserts. M2,5 thread. Carbide ball tip Ø 3 mm. Cable length 2,9 m. USB type A connector. 5-pin DIN 45322 connector.



Max. mechanical frequency 60 Hz
Power consumption: 70 mAh
Normal measurement interval = 80ms (maximum accuracy)
Minimum measurement interval = 20ms (fastest transfer data).
Stabilisation time after power on = 12 min



0,09 µm/°C



20 ± 0,5°C



10°C to +40°C



80 %



IP65 (IEC 60529)



Mobile weight: 8 g



Transport packaging



Identification number



Inspection report with a declaration of conformity





DIN 32876 Part 1



See table



See standard probes technical data



Cable length: 2 m. DIN 45322 plug connector, 5 poles. Use to connect to a device with an analogue input. For more information, refer to technical data for standard probes



Supply voltage: ± 15 V
Consumption: 15 mA
Adjustable load: > 1 k Ω . Can be used in any position.
Special versions on request: Sensitivity: 2 V/mm, 5 V/mm, 10 V/mm output: 0 V to +10 V (max +10 V)



See standard probes technical data



See standard probes technical data



See standard probes technical data



80 %



See standard probes technical data



See standard probes technical data



Transport packaging



Identification number



See standard probes technical data

DC Probes ± 2 mm (Output Signal in V)

Probe provided with an electronic box which converts the signal to obtain an output DC voltage

Typically used for direct connection to a computer unit or interface equipped with an analogue input

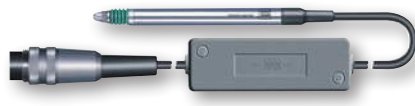

GTL 21 DC

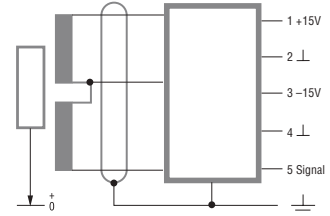

DIN 5 pin connection schematic

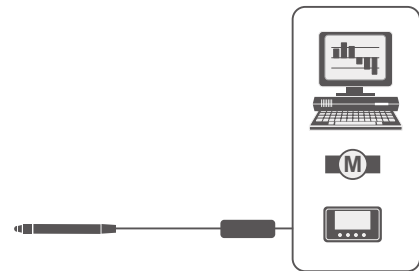

Connection of DC probe to a computer, an interface or a tracker

			Measuring range, mm	Nominal measuring force*, N	Bolt retraction	Sealing bellows	Output voltage, V	Sensitivity, V/mm
03230059	GTL 21 DC	± 2	0,63	Mechanical	Viton	± 2	1	
03230058	GTL 22 DC	± 2	0,63	Mechanical / vacuum	Viton	± 2	1	

	Measuring bolt travel, mm	Max. permissible error for deviations in linearity, μ m (L in mm)	Repeatability, μ m	Data sheet No.
GTL 21 DC	4,3	$0,2 + 3,5 \cdot L^2$	0,1	03200396
GTL 22 DC	4,3	$0,2 + 3,5 \cdot L^2$	0,1	03200397

* Electrical zero (N) ± 25 % deviation limit. Valid in vertical mounting position, measuring bolt lowered and in static measuring.



DC Probes ± 5 mm (Output Signal in V), with Extended Measuring Range

Probe provided with an electronic box which converts the signal to obtain an output DC voltage

Typically used for direct connection to a computer unit or an interface equipped with an analogue input

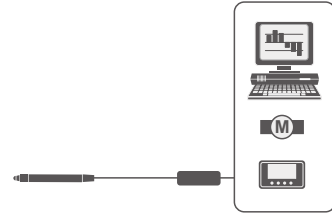

Connection of DC probe to a computer, an interface or a plotter

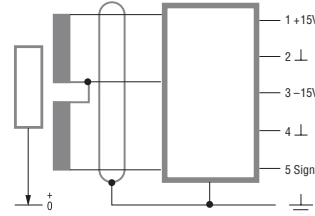

DIN 5 pin connector schematic

No	=	Measuring range, mm	Nominal measuring force*, N	Bolt retraction	Sealing bellows	Output voltage, V	Sensitivity, V/mm
03230086	GT 61 DC	± 5	0,9	Mechanical	Viton	± 5	1
03230087	GT 62 DC	± 5	0,9	Mechanical / vacuum	Viton	± 5	1

=	Measuring bolt travel, mm	Max. permissible error for deviations in linearity, μm (L in mm)	Repeatability, μm	Data sheet No.
GT 61 DC	10,3	1 + 4 · L	0,1	03200519
GT 62 DC	10,3	1 + 4 · L	0,1	03200520

* Electrical zero (N) ± 25 % deviation limit. Valid in vertical mounting position, measuring bolt lowered and in static measuring.



DIN 32876 Part 1



See table



See standard probes technical data



Cable length: 2 m. DIN 45322 plug connector, 5 poles. Use to connect to a device with an analogue input. For more information, refer to technical data on standard probes



Supply voltage: ± 15 V
Consumption: 15 mA
Adjustment load: > 1 kΩ
Can be used in any position. Special versions on request.
Sensitivity: 2 V/mm, 5 V/mm, 10 V/mm
Output: 0 V to +10 V (max +10 V).



See standard probes technical data



See standard probes technical data



See standard probes technical data



80 %



See standard probes technical data



See standard probes technical data



Transport packaging



Identification number



See standard probes technical data



DC Miniature Probes ± 1 mm (Output Signal in V)

Probe provided with an electronic box which converts the signal to obtain an output DC voltage

Typically used for direct connection to a computer unit or an interface equipped with an analogue input

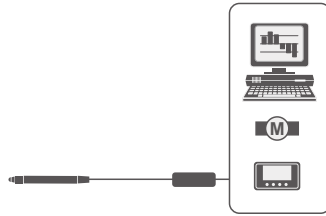

Connection of a DC probe to a computer, an interface or a plotter

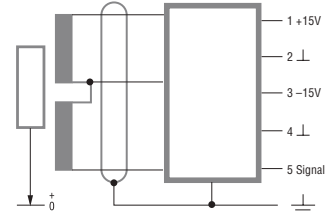

DIN 5 pin connection schematic



DIN 32876 Part 1



See table



See standard probes technical data



Cable length: 2 m. DIN 45322 plug connector, 5 poles. Use to connect to a device with an analog input. For more information, refer to technical data for standard probes



Drive voltage: ± 15 V
Consumption: 15 mA
Adjustment load: > 1 kΩ. Can be used in any position. Special versions on request. Sensitivity: 2 V/mm, 5 V/mm, 10 V/mm Output: 0 V à +10 V (max +10 V)



See standard probes technical data



See standard probes technical data



See standard probes technical data



80 %



See standard probes technical data



See standard probes technical data



Transport packaging



Identification number



See standard probes technical data

03230085	GT 44 DC	± 1	0,4	Mechanical / vacuum	Viton	± 1	1

GT 44 DC	2,1	0,2 + 5 · L ³	0,1	03200518

* Electrical zero (N) ± 25 % deviation limit. Valid in vertical mounting position, measuring bolt lowered and in static measuring.



Lever DC Probes ± 0,3 mm (Output Signal in V)

Probe provided with an electronic box which converts the signal to obtain an output DC voltage

Typically used for direct connection to a computer unit or an interface equipped with an analogue input

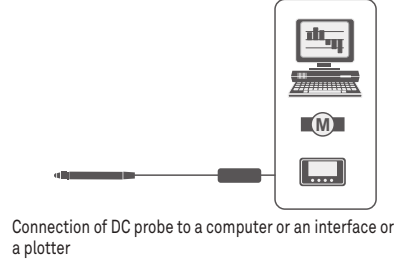
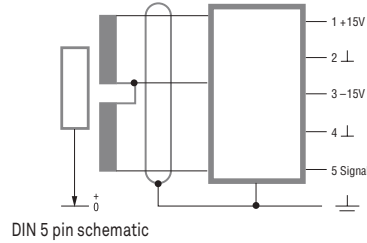

No	=	Measuring range, mm	Nominal measuring force*, N	Bolt retraction	Sealing bellows	Output voltage, V	Sensitivity, V/mm
03230081	GT31 DC	± 0,3	0,1	Without retraction	Without bellows	± 0,3	1

=	Measuring bolt travel, mm	Max. permissible error for deviations in linearity, µm (L in mm)	Repeatability, µm	Data sheet No.
GT31 DC	0,7	0,2 + 50 · L ²	0,1	03200484

* Electrical zero (N) ± 25 % deviation limit. Valid in vertical mounting position, measuring bolt lowered and in static measuring.



DIN 32876 Part 1



See table



See standard probes technical data



Cable length: 2 m. DIN 45322 plug connector, 5 poles. Use to connect to a device with an analog input. For more information, refer technical data on standard probes



Drive voltage: ± 15 V
Consumption: 15 mA
Adjustment load: > 1 kΩ. Can be used in any measuring position. Special versions on request.
Sensitivity: 2 V/mm, 5 V/mm, 10 V/mm
Output: 0 V to +10 V (max +10 V)



See standard probes technical data



See standard probes technical data



See standard probes technical data



80 %



See standard probes technical data



See standard probes technical data



Transport packaging



Identification number



See standard probes technical data



GT 41 / GT 42 Miniature Probes, ± 0,3 mm, 0,7 mm Bolt Travel

Compact probes for use in small spaces – Designed to be mounted on a measuring head for the inspection of bores and similar features.



DIN 32876 Part 1



See table



Nickel-plated housing. Stainless steel measuring bolt, hardened. Sealing bellows: Nitrile = resistant elastomer. Viton = highly resistant fluoroelastomer.



Fixing shank Ø 8 mm. Ball-bearing measuring bolt. Both lower and upper stops are fixed. Interchangeable insert. M2,5 thread. Carbide ball tip Ø 3 mm. 2 m long cable. 5-pin DIN 45322 connector.



Supply frequency: 13 kHz (± 5 %) Max. mechanical frequency** 60 Hz.



0,1 µm/°C



20 ± 0,5°C



-10°C to 65°C



80 %



Level of protection: IP65 (IEC 60529)



Mobile weight: 2 g



Transport packaging



Identification number



Inspection report with a declaration of conformity



GT 41

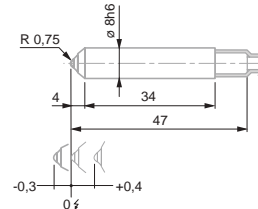

GT 41



GT 42

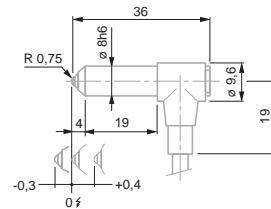

GT 42

No	=	Measuring range, mm	Nominal measuring force*, N	Bolt retraction	Sealing bellows
03230001	GT 41	± 0,3	0,63	None	Nitrile
03230002	GT 42	± 0,3	0,63	Vacuum	Nitrile

	=	Measuring bolt travel, mm	Max. permissible error for deviations in linearity, µm (L en mm)	Repeatability, µm	Hysteresis, µm	Setting of lower stop of measuring bolt***, mm	Cable output	Data sheet No.
GT 41	0,7	0,2 + 5 · L ²	0,01	0,01	Fixed stops: lower -0,3 upper +0,4	Axial	03200258	
GT 42	0,7	0,2 + 5 · L ²	0,01	0,01	Fixed stops: lower -0,3 upper +0,4	Radial	03200259	

* Electrical zero (N) ± 25 % deviation limit. Valid in vertical mounting position, measuring bolt lowered and in static measuring.

** For an amplitude of 10 % to the last value of the measuring range.

*** Distance from electrical zero.



GT 43 / GT 44 Miniature Probes, ± 1,0 mm , 2,1 mm Bolt Travel

Compact probes for use in small spaces – Designed to be mounted on a measuring head for the inspection of bores and similar features.



GT 43

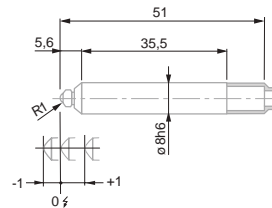

GT 43



GT 44

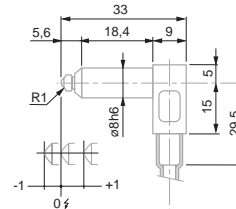

GT 44

			Measuring range, mm	Nominal measuring force*, N	Bolt retraction	Sealing bellows
03230035	GT 43	± 1	0,4	Mechanical	Viton	
03230017	GT44	± 1	0,4	Vacuum	Viton	

	Measuring bolt travel, mm	Max. permissible error for deviations in linearity, µm (L en mm)	Repeatability, µm	Hysteresis, µm	Setting of lower stop of bolt***, mm	Cable output	Data sheet No.	
GT 43	2,1	0,2 + 5 · L ²	0,1	0,15	Fixed stops: lower -1,05 upper +1,05	Axial	03200260	
GT44	2,1	0,2 + 5 · L ²	0,1	0,15	Fixed stops: lower -1,05 upper +1,05	Radial	03200261	

* Electrical zero (N) ± 25 % deviation limit. Valid in vertical mounting position, measuring bolt lowered and in static measuring.

** For an amplitude of 10 % to the last value of the measuring range.

*** Distance from electrical zero.



DIN 32876 Part 1



See table



Nickel-plated housing, Stainless steel measuring bolt, hardened. Sealing bellows: Nitrile = resistant elastomer. Viton = highly resistant fluoroelastomer.



Fixing shank Ø 8 mm. Ball-bearing measuring bolt. Both lower and upper stops are fixed. Interchangeable insert. Carbide ball tip Ø 3 mm. 2 m long cable. 5-pin DIN 45322 connector.



Supply frequency: 13 kHz (± 5 %) Max. mechanical frequency**: 60 Hz.



0,1 µm/°C



20 ± 0,5°C



-10°C to 65°C



80 %



Level of protection: IP65 (IEC 60529)



Mobile weight: 2 g



Transport packaging



Identification number



Inspection report with a declaration of conformity



Probes, Unbranded Execution, Series 410 ± 1 mm, 2,5 mm Range, Short Body

Universal probes for common but constraining applications.

- 8 mm diameter probe body that can be clamped over its entire length.
- Ball bearing measuring bolt.
- Hardened steel body, hard-chrome plated.
- Degree of protection to IP62.
- Flexible axial cable exit fitted with a steel spring to prevent the cable from breaking.
- Other probes compatible with measuring equipment from other makers also available on request.

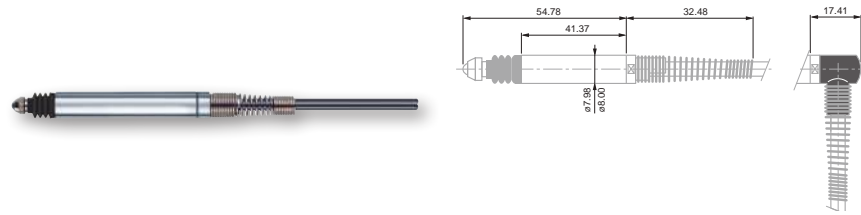

410

410 and accessory with radial cable exit (delivered with probe)

- DIN 32876 Part 1
- See in the table
- Nickel-plated housing. Stainless steel measuring bolt, hardened. Sealing bellows: Nitrile = resistant elastomer
- Fixing shank Ø 8 mm. Ball-bearing measuring bolt. Distance from electrical zero of both stops is either adjustable (downward) or depending on the position of the lower stop (upward). Interchangeable measuring insert with a 3 mm dia. tungsten carbide ball tip plus M2,5 thread. 2 m long cable. DIN 45322 5-pin connector.
- Supply frequency: 13 kHz (± 5 %) Max. mechanical frequency*: 60 Hz.
- 0,025 µm/°C
- 20 ± 0,5°C
- 10°C to +60°C
- IP65 (IEC 60529)
- Mobile weight: 3,1 g
- Shipping packaging
- Identification number

96410012	410	Measuring range, mm	Nominal measuring force*, N	Bolt retraction	Sealing bellows
		± 1	0,60	Mechanical	Nitrile

410	Measuring bolt travel, mm	Max. permissible error for deviations in linearity, µm (L en mm)	Repeatability, µm	Setting of lower stop of the measuring bolt***, mm (factory setting)	Cable output	Data sheet No.
	2,5	0,2 % (for a measuring span of ± 1 mm)	0,1	Adjustable from -1,2 to 0 (factory setting -1,08)	Axial and radial	F96410012

* Electrical zero (N) ± 25 % deviation limit. Valid in vertical mounting position, measuring bolt lowered and in static measuring.
 ** For an amplitude of 10 % to the last value of the measuring range.
 *** Distance from electrical zero.



Probes, Unbranded Execution, Series 160 ± 1 mm, 3,3 mm Bolt Travel, Short Body, Ø 6 mm

Compact size and robust construction makes these probes ideal for continuous use.

- Probe body Ø 6 mm.
- Clamping possible over entire length.
- Measuring bolt guided on ball bearing.
- Hard-chrome plated probe body, hardened steel.
- Protection level: IP62 as per IEC 60529.
- Executions compatible with measuring equipment from other suppliers available on request.

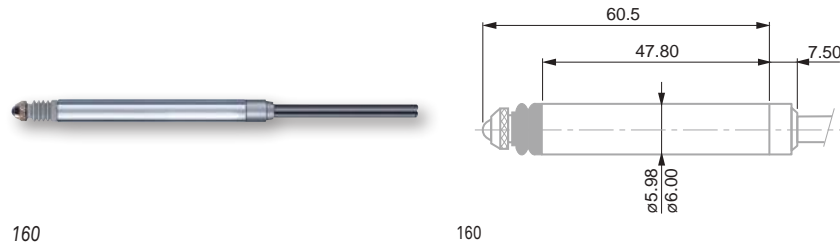

96160013	160	± 1	0,60	Mechanical	Viton

160	3,3	0,2 % (for a measuring span of ± 1 mm)	0,1	Adjustable from -1,2 to 0 (factory setting -1,08)	Axial	F96160013

* Electrical zero (N) ± 25 % deviation limit. Valid in vertical mounting position, measuring bolt lowered and in static measuring.

** For an amplitude of 10 % to the last value of the measuring range.

*** Distance from electrical zero.



DIN 32876 Part 1



See table



Nickel-plated housing. Stainless steel measuring bolt, hardened. Sealing bellows: Viton = highly resistant fluoroelelastomer.



Probe body Ø 6 mm. Measuring bolt guided on ball bearing. Distance between the lower stop and electrical zero adjustable. Interchangeable measuring insert. Thread M2. Carbide ball tip Ø 3 mm. 2 m long cable. DIN 45322 5-pin connector.



Supply frequency: 13 kHz (± 5 %) Max. mechanical frequency**: 60 Hz.



0,025 µm/°C



20 ± 0,5°C



0°C to 60°C



Protection level: IP62 (IEC 60529)



Mobile weight: 2,5 g



Transport packaging



Identification number



Probes, Unbranded Execution, Series 430 and 451, ± 0,5 mm, 1,25 et 2,10 mm Measuring Bolt Travel, Miniature

Their compact size and robust construction make them the ideal probes for a frequent use.

- Probe body Ø 8 mm.
- Clamping possible over its entire length.
- Measuring bolt on ball bearing guide.
- Hard chrome-plated probe body, hardened steel.
- Level of protection: IP62 as per IEC 60529.
- Probes compatible with measuring equipment from other suppliers also available on request.

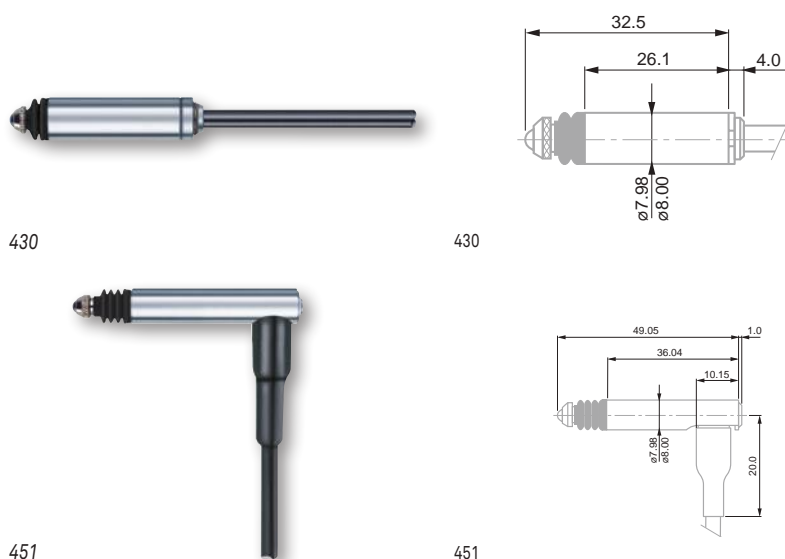

- DIN 32876 Part 1
- See table
- Nickel-plated housing. Stainless steel measuring bolt, hardened. Sealing bellows: Nitrile = resistant elastomer.
- Probe body Ø 8 mm. Measuring bolt guided on ball bearing. Adjustable distance between lower bolt and electrical zero. Interchangeable measuring insert. Thread M2,5. Carbide ball tip Ø 3 mm. Cable length: 2 m DIN 45322 5-pin connector.
- Supply frequency: 13 kHz (± 5 %). Max. mechanical frequency*: 60 Hz..
- 0,025 µm/°C
- 20 ± 0,5°C
- 0°C to 60°C
- Level of protection: IP65 (IEC 60529)
- Mobile weight: 1,9 g (Series 439)
Mobile weight: 3,0 g (Series 451)
- Transport packaging
- Identification number

No	=	Measuring range, mm	Nominal measuring force*, N	Bolt retraction	Sealing bellows
96430029	430	± 0,5	0,75	Mechanical	Nitrile
96441041	451	± 0,5	0,60	Mechanical	Nitrile

=	Measuring bolt travel, mm	Max. permissible error for deviations in linearity, µm (L in mm)	Repeatability, µm	Setting of lower stop of measuring bolt***, mm (factory setting)	Cable output	Data sheet Nb
430	1,25	0,2 % (for a measuring span of ± 0,5 mm)	0,2	Adjustable from -0,7 to 0 (factory setting -0,58)	Axial	F96430029
451	2,10	0,2 % (for a measuring span of ± 0,5 mm)	0,1	Fixed stops (factory setting: -0,58)	Radial	F96441041

* Electrical zero (N) ± 25 % deviation limit. Valid in vertical mounting position, measuring bolt lowered and in static measuring.
 ** For an amplitude of 10 % to the last value of the measuring range.
 *** Distance from electrical zero.



GT31 Lever Probes ± 0,3 mm, 0,3 mm Measuring Travel, Inclinable Lever



GT 31 with lever in perpendicular position

Well suited for use where probes with axial movement measuring bolts are inconvenient for measurements.

- Inclinable lever for measuring in two directions.
- Balanced lever system on ball-bearing.
- Interchangeable measuring insert, with carbide ball tip, inclinable through to 180°.
- Automatic reversal of the probing direction while the indication remains unchanged.
- Protected against shocks by 2 safety clutches.
- One-piece housing provided with 2 dovetails.
- Level of protection: IP40 as per IEC 60529.

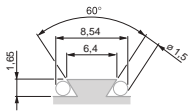

GT 31

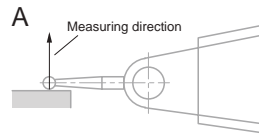

GT 31
Figure A - the leverage matches 1:1, no correction of the measured value needed

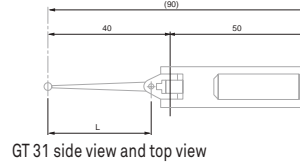
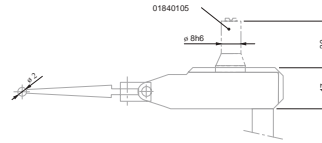

GT 31 side view and top view

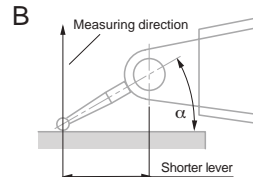

GT 31
Figure B - the leverage is no longer 1:1, correction of the measured value is needed.

Note
(Fig. A) With the insert lying parallel to the workpiece surface, the leverage matches 1:1. Therefore, no correction of the measured values is needed.
(Fig. B, angle α) Any other position will change the effective lever length, so that read values must be corrected. In this connection, please consult the instruction manual.

			Measuring range, mm	Nominal measuring force*, N	Lever retraction	Sealing bellows
03210802	GT 31	± 0,3	0,1	Without	Without bellows	
03210801	GT 31	± 0,3	0,02	Without	Without bellows	
03210803	GT 31	± 0,3	0,1	Without	Without bellows	

	Measuring lever travel, mm	Max. permissible error for deviations in linearity, μm (L in mm)	Repeatability, μm	Hysteresis, μm	Setting of lower stop of the measuring insert***, mm	Cable output	Data sheet No.
GT 31	0,7	$0,2 + 50 \cdot L^2$	0,1	0,25	Fixed lower and upper stops	Angled	03200266

* Electrical zero (N) ± 25 % deviation limit. Valid in vertical mounting position, measuring bolt lowered and in static measuring.
 ** For an amplitude of 10 % to the last value of the measuring range.
 *** Distance from electrical zero.

- DIN 32876 Part 1
- ± 0,3 mm
- All-metal housing, matt-chromium finish
- 2 dovetail attachments for clamping. Both lower and upper stops are fixed. Stainless steel measuring stem. Interchangeable measuring inserts. Carbide ball tip Ø 2 mm. Cable length: 2 m. DIN 45322, 5 pin connector. Other measuring inserts available as optional accessories..
- Supply frequency: 13 kHz (± 5 %) Max. mechanical frequency**: 25 Hz.
- 20 ± 0,5°C
- 5°C to 60°C
- 80 %
- Protection level: IP40 (IEC 60529)
- Mobile weight: 12 g
- Transport packaging
- Identification number
- Declaration of conformity





DIN 32876 Part 1



See table



Hardened steel probe body, nickel-plated



Linear guidance on ball bearing, 4 M6 mounting threads. Fixed mechanical stops. Interchangeable inserts. Dovetail clamp for mounting holder. Cable length: 2 m. 5-pin connector DIN 45322.



Supply frequency: 13 kHz (± 5 %) Max. mechanical frequency**: 25 Hz.



-0,14 µm/°C



20 ± 0,5°C



-10°C to 65°C



80 %



IP50 (IEC 60529)



Mobile weight: 110 g



Transport packaging



Identification number



Inspection report with a declaration of conformity



Application: Minimal space usage with FMS units placed side by side



Application: small component measuring thanks to offset inserts

Probes with Parallel Guidance, ± 2 mm or ± 2,9 mm, 5,8 mm Measuring Travel

Modular construction enables the combination of elements, for example, such as springs, pneumatic cylinders and stops.

These universal probes are suited for multigauging fixtures as well as machines equipped with integrated inspection routines.

Versatility of applications:

- Probe can be used in any position for measuring.
- Measuring direction is adjustable.
- Retraction of the measuring insert is adjustable.
- Measuring force is adjustable depending on the accessory used.
- Possibility of using off-centre measuring inserts.

Unique design:

- Compact assembly noted for its robustness.
- Ball bearing guided movement.
- Wide variety of measuring inserts, holders and other accessories for measuring applications.
- LVDT execution versions compatible with melectronic equipment from other suppliers available on request.

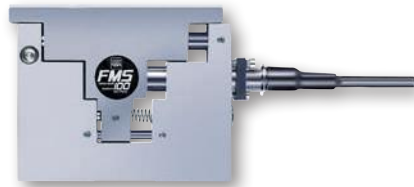

FMS 100



FMS 102

No	=	Measuring range, mm	Nominal measuring force*, N	Bolt retraction	Sealing bellows
03230019	FMS 100	± 2	2	Retraction by air pressure (optional)	Without bellows
03230049	FMS 130	± 2,9	2	Retraction by air pressure (optional)	Without bellows
03230028	FMS 102	± 2	2	Retraction by air pressure (optional)	Without bellows
03230050	FMS 132	± 2,9	2	Retraction by air pressure (optional)	Without bellows

=	Measuring bolt travel, mm	Max. permissible error for deviation in linearity, µm (L in mm)	Repeatability, µm	Hysteresis, µm	Setting of lower stop of measuring bolt***, mm	Cable output	Data sheet No.
FMS 100	5,8	0,2 + 3 · L ³	0,5	0,5	Fixed stops: lower -2,9 upper +2,9	Parallel	03200253
FMS 130	5,8	0,2 + 3 · L ³	0,5	0,5	Fixed stops: lower -2,9 upper +2,9	Parallel	03200342
FMS 102	5,8	0,2 + 3 · L ³	0,5	0,5	Fixed stops: lower -2,9 upper +2,9	Parallel	03200254
FMS 132	5,8	0,2 + 3 · L ³	0,5	0,5	Fixed stops: lower -2,9 lower +2,9	Parallel	03200343

* Electrical zero (N) ± 25 % deviation limit. Valid in vertical mounting position, measuring bolt lowered and in static measuring.

** For an amplitude of 10 % to the last value of the measuring range.

*** Distance from electrical zero.



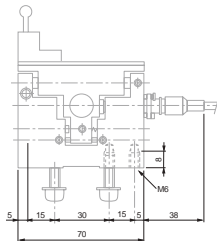

FMS 100

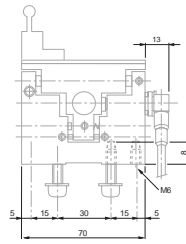

FMS 102

Configuration and Application of TESA FMS Probes

Shown below are the different possibilities for the activation and retraction of the probe insert during measurement cycles.

APPLICATION EXAMPLE A

- Activation of the probe insert in the direction of the part to be inspected using the measuring force produced by the spring set.
- Without retraction of the insert.

Result A

During the placing of a new part to be measured, the measuring insert remains in its contact position thanks to the measuring force produced by the spring set.

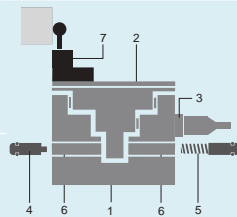

- 1 Static probe body
- 2 Mobile probe body
- 3 Measuring element with fine adjust
- 4 Adjustable stop
- 5 Spring set for producing measuring force
- 6 M6 mounting thread
- 7 Holder

APPLICATION EXAMPLE B

- Activation of the probe insert in the direction of the part to be measured using the measuring force of the spring set.
- Retraction of the insert by pneumatic pressure through a pneumatic connection.

Result B

During the placing of a new part to be measured, the measuring insert is retracted through activation of pressure via the pneumatic actuator.

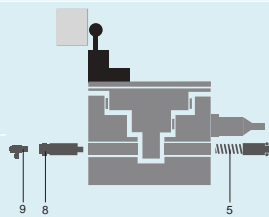

- 5 Spring set for producing measuring force
- 8 Pneumatic actuator (Part No. 03260440)
- 9 Connector (Part No. 024388)

APPLICATION EXAMPLE C

- Activation of the probe insert in the direction of the part to be inspected by pneumatic pressure and the measuring force of the spring set.
- Retraction of the insert by disabling the pneumatic pressure.

ATTENTION !

The force of the spring set (5) must be equal to that of the auxiliary spring element (10).

Result C

During the placing of a new part to be measured, the measuring insert is automatically retracted due to the disabling of the pneumatic pressure, which guarantees about security during the measuring cycle.

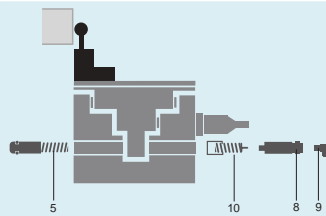

- 5 Spring set for producing measuring force
- 8 Pneumatic actuator (Part No. 03260440)
- 9 Connector (Part No. 024388)
- 10 Auxiliary spring element (Part No. 03260445)

This configuration is typically preferred when there is lack of space for connecting a pneumatic actuator (left side of example B).



- DIN 32876 Part 1
- See table
- Hardened steel probe body, nickel-plated
- Linear guidance on ball bearing. 4 M6 mounting threads.. Fixed mechanical stops.. Interchangeable inserts. Holder with dovetail clamping. Cable length: 2 m. 5-pin connector DIN 45322.
- Supply frequency: 13 kHz (± 5 %). Max. mechanical frequency*: 25 Hz.
- 0,14 µm/°C
- 20 ± 0,5°C
- 10°C to 65°C
- 80 %
- IP54 (IEC 60529)
- Mobile weight: 110 g
- Shipping packaging
- Identification number
- Inspection report with a declaration of conformity



Application: measurement with a protected FMS



FMS 102-P



FMS 100-P

Probes with Parallel Guidance, ± 2 mm or ± 2,9 mm, 5,8 mm Measuring Travel – Protected Version

- FMS 100-P, 102 -P, 130-P, 132-P provide dust protection of the 2 side faces.

Modular concept for combining elements, for example, such as springs, pneumatic actuators and stops.

These universal probes are suitable for mutigauging inspection fixtures as well as machines with integrated automated inspection routines.

Versatility of applications:

- Probe can be used in any position for measuring
- Measuring direction can be changed
- Retraction of the measuring insert is adjustable
- Measuring force is adjustable, depending on the accessory used
- Possibility of using off-centre measuring inserts

Unique design:

- Compact assembly noted for its robustness
- Ball bearing guided movement
- Wide variety of measuring inserts, holders and other accessories for measuring applications
- LVDT execution versions compatible with melectronic equipment from other suppliers available on request.

No	=	Measuring range, mm	Nominal measuring force*, N	Bolt retraction	Sealing bellows
03230037	FMS100-P	± 2	2	Retraction by air pressure (optional)	Without bellows
03230051	FMS130-P	± 2,9	2	Retraction by air pressure (optional)	Without bellows
03230038	FMS102-P	± 2	2	Retraction through air pressure (optional)	Without bellows
03230052	FMS132-P	± 2,9	2	Retraction through air pressure (optional)	Without bellows

	Measuring bolt travel, mm	Max. permissible errors for deviations in linearity, µm (L en mm)	Repeatability, µm	Hysteresis, µm	Setting of lower stop of measuring bolt***, mm	Cable output	Data sheet No.
FMS100-P	5,8	0,2 + 3 · L ³	0,5	0,5	Fixed stops: lower -2,9 upper +2,9	Parallel	03200283
FMS130-P	5,8	0,2 + 3 · L ³	0,5	0,5	Fixed stops: lower -2,9 upper +2,9	Parallel	03200344
FMS102-P	5,8	0,2 + 3 · L ³	0,5	0,5	Fixed stops: lower -2,9 upper +2,9	Angled	03200289
FMS132-P	5,8	0,2 + 3 · L ³	0,5	0,5	Fixed stops: lower -2,9 upper +2,9	Angled	03200345

* Electrical zero (N) ± 25 % deviation limit. Valid in vertical mounting position, measuring bolt lowered and in static measuring.

** For an amplitude of 10 % to the last value of the measuring range.

*** Distance from electrical zero.



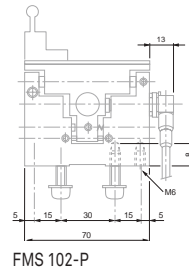
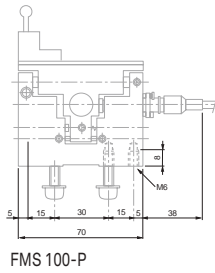

Configuration and Application of TESA FMS Probes

Shown below are the different possibilities for the activation and retraction of the probe insert during measurement cycles.

APPLICATION EXAMPLE A

- Activation of the probe insert in the direction of the part to be inspected using the measuring force produced by the spring set.
- Without retraction of the insert.

Result A
During the placing of a new part to be measured, the measuring insert remains in its contact position thanks to the measuring force produced by the spring set.

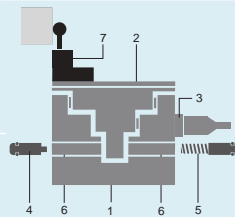

- 1 Static probe body
- 2 Mobile probe body
- 3 Measuring element with fine adjust
- 4 Adjustable stop
- 5 Spring set for producing measuring force
- 6 M6 mounting thread
- 7 Holder

APPLICATION EXAMPLE B

- Activation of the probe insert in the direction of the part to be measured using the measuring force of the spring set.
- Retraction of the insert by pneumatic pressure through a pneumatic connection.

Result B
During the placing of a new part to be measured, the measuring insert is retracted through activation of pressure via the pneumatic actuator.

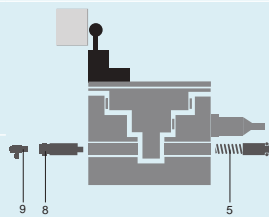

- 5 Spring set for producing measuring force
- 8 Pneumatic actuator (Part No. 03260440)
- 9 Connector (Part No. 024388)

APPLICATION EXAMPLE C

- Activation of the probe insert in the direction of the part to be inspected by pneumatic pressure and the measuring force of the spring set.
- Retraction of the insert by disabling the pneumatic pressure.

ATTENTION !
The force of the spring set (5) must be equal to that of the auxiliary spring element (10).

Result C
During the placing of a new part to be measured, the measuring insert is automatically retracted due to the disabling of the pneumatic pressure, which guarantees about security during the measuring cycle.

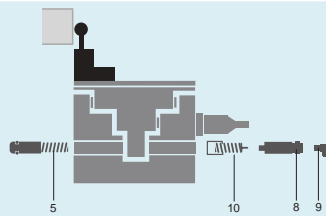

- 5 Spring set for producing measuring force
- 8 Pneumatic actuator (Part No. 03260440)
- 9 Connector (Part No. 024388)
- 10 Auxiliary spring element (Part No. 03260445)

This configuration is typically preferred when there is lack of space for connecting a pneumatic actuator (left side of example B).



TESATRONIC TT10 Probe Display Unit

- Perfect for inspection on the surface plate, on an inspection work station in production or directly on a machine.
- Battery power supply.
- Can be used wherever the presence of a power cable can inhibit measuring operations.
- Frequently used with a GT 31 lever probe for setting operations.
- Simple-to-use function keys and easy reading of the combined digital/ analogue indication.
- Liquid crystal (LCD) indication display. No pointer which ensures an excellent repeatability and negligible hysteresis.
- 3 measuring ranges, switchable manually or automatically depending on the measured value.
- Metric/inch conversion.
- Signal amplification (5x) for easy display setting.
- Quick zero-setting with the help of a touch key thanks to digital technology.
- Signal input for one probe.
- Opto-coupled RS232 compatible digital output.



TT10

TT10 with template

- DIN 32876 Part 1
- Circular scale Ø 40 mm
- 3-decade display plus minus sign
- 9 x 4,5 mm
- 66 x 57 mm LCD display size
- Value limit for a temperature of 20°C and a relative humidity of ≤ 50 %: Analogue display: 2 % Digital display: 2 %
- ± 1 digital step
- 95 x 170 x 68 mm (W x D x H)
- Resistant plastic material
- For a temperature of 20°C and a relative humidity of ≤ 50 %: Analogue and digital response time: ≤ 100 ms. Holding of digital display: ≥ 100 ms.
- For a temperature of 20°C and a relative humidity of ≤ 50 %: Zero drift and signal amplification: ≤ 0,005 %/°C. Display frequency limit with respect to input signal: 10 Hz
- Opto-coupled RS232
- Supply: 3,5 V to 4,5 V, 3 batteries AA 1,5 V, type LRC 6. Power consumption: ≈ 7 mW/3,5 V Probe supply voltage: 0,7 V Supply frequency: 13 ± 0,65 kHz









	Number of probes inputs	Automatic conversion of range
TESATRONIC TT10 portable display unit for TESA inductive probes	1	●

		Measuring range zoom x5	Memory
04430008	TESATRONIC TT10 portable display unit for TESA inductive probes	●	-





With a measuring support

-  0°C to 60°C
-  -10°C to 70°C
-  80 %, without condensation
-  Level of protection: IP42 (IEC 60529)
-  EN 500081-1
EN 500081-2
EN 500082-1
EN 500082-2
-  490 g (including batteries)
-  Transport packaging
-  Identification number
-  Declaration of conformity

STANDARD ACCESSORIES:

- 04768002** 3 AA 1,5 V batteries, type LRC 6 for TT10
- 04460007** 10x templates for TT10



With a measuring support

OPTIONAL ACCESSORIES:

- 04768000** Hand switch for manually triggering data transfer. Jack plug connector, 1,8 m
 - TESA SPC PRINTER printer
 - TESATRONIC TT display units
- 04768001** Foot switch for triggering data transfer. Jack plug, 1,8 m
 - TESA SPC PRINTER printer
 - TESATRONIC (TT) display units
- 04761023** Cable: miniDIN 8p/m to Sub-D 9p/f, 2m for TT10 and MICRO-HITE manual versions 10/11/12
- 04761024** Cable: miniDIN 8p/m to Sub-D 25p/m, 2m for TT10 and MICRO-HITE manual versions 10/11/12



TESATRONIC TT20 and TT60 Probe Display Units

- DIN 32876 Part 1
- 110 mm scale length
- 50 scale divisions
- 6-decade display plus minus sign
- 12,5 x 6,6 mm
- 126 x 62 mm LCD display
- Value limit for a temperature of 20°C and a relative humidity of ≤ 50 %
 TT20:
 Analogue display: 2%
 Digital display 0,3%
 Digital output: 0,3%
 TT60:
 Analog display: 2%
 Digital display: 0,3%
 Analogue output: 0,3%
 Digital output: 0,3%
- ± 1 numerical interval
- 255 x 235 x 120 mm (W x D x H)
- Resistant plastic material
- For a temperature of 20°C and a relative humidity of ≤ 50 %:
 TT20:
 Response time of analogue, digital and LED classification displays: ≤ 80 ms.
 Maintenance of digital display: 80 ms.
 TT60:
 Response time of analogue, digital and LED classification displays: ≤ 80 ms.
 Holding of digital display: 80 ms.
 Response time of the analogue output signal in relation to analogue display: ≤ 30 ms.

- Functional reliability.
- User-friendly.
- Essential for inspection in production or metrology laboratory.

TESATRONIC TT20

Combined digital and analogue indication

2 probe inputs for single measurements, sum and difference measurements

- Large LC display for comfortable and error-free reading.
- Pseudo-analogue bargraph indication for a better repeatability and negligible hysteresis.
- Choice between pointer or bargraph indication.
- LCD display for all functions.
- 7 measuring ranges, switchable manually or automatically according to the measured value.
- Direct conversion from metric to inch units.
- Touch button for the indication setting of of each measuring channel.
- Keys for introducing limit values.
- Classification of values (3 classes) and display through colour LEDs with signal outputs.
- Locking of displayed values for step by step measurement routines.
- Automatic recognition of the type of connected TESA probe with adaptation of the measurement signals to the value of output connected (valid only for TESA probes produced from 1997 onwards).
- Opto-coupled RS232 output, bidirectional.
- Power supply through mains adapter.

TESATRONIC TT60

Same features as TESATRONIC TT20, but with following added functions:

- Memory for retaining extreme values "max.", "min.", "max.-min." along with mean value obtained from "max." minus "min.".
- Dynamic measurement with acquisition of >100 single values.
- Value classification with output signals through contact relay for 5, 10, 20 or 40 acceptable classes.
- Analogue output for exterior processing of signals.





TT60



TT20

		Measuring range zoom x5	Memory
04430009	TESATRONIC TT20 Display unit for 1 or 2 inductive probes	-	-
04430010	TESATRONIC TT60 Display unit for 1 or 2 inductive probes	-	●



	 Number of probe inputs	 Automatic switching of range
TESATRONIC TT60 Display unit for 1 or 2 inductive probes		●
TESATRONIC TT20 Display unit for 1 or 2 inductive probes		●

DELIVERED WITH THE FOLLOWING ACCESSORIES:

04761054	Battery charger 100 ÷ 200 VAC 50 ÷ 60 Hz, 6,6 V DC, 750 mAh supplied without power cable
04761055	Mains cable EU for charger 0471054

OPTIONAL ACCESSORIES:

04768000	Hand switch for manually triggering data transfer. Jack plug connector, 1,8 m – TESA SPC PRINTER printer – TESATRONIC TT display units
04768001	Foot switch for triggering data transfer. Jack plug, 1,8 m – TESA SPC PRINTER printer – TESATRONIC (TT) display units
04761062	Opto-USB cable, Duplex, 2m Bidirectional communication
04761049	Opto-RS cable, Duplex, 2m Bidirectional communication

 For a temperature of 20°C and a relative humidity of ≤ 50 %:
TT20:
Response time of analogue, digital and LED classification displays: ≤ 80 ms.
Maintenance of digital display: 80 ms.
TT60:
Response time of analogue, digital and LED classification displays: ≤ 80 ms.
Holding of digital display: 80 ms.
Response time of the analogue output signal in relation to analogue display: ≤ 30 ms.

 RS232 opto-coupled output

 TT60: Voltage Range: ± 2 V to ± 10 V. Output current: ≤ 2 mA. Load adjustment: ≥ 5 kΩ. Background noise (probe at electrical zero) ≤ 1 mV. Reference potential: ground 0 V.

 Supply: 6,5 V DC up to 7,3 V DC. Supply frequency: 13 ± 0,65 kHz. Power consumption: 2 W. Monitored voltage variations. Probe supply voltage: 3 V.

 0°C to 60°C

 -10°C to 70°C

 80 %, without condensation

 Protection of frontal face: IP54 (IEC 60529, DIN 40 050)

 IEC/EN 61326-1
USA: CFR47, Part 15, Subpart B, Class B, Digital Device

 1,1 kg

 Transport packaging

 Identification number

 Declaration of conformity



- DIN 32876 Part 1
- 110 mm scale length
- 50 scale divisions
- 6-decade display plus minus sign
- 12,5 x 6,6 mm
- 126 x 62 mm LCD display
- Limit value for a temperature of 20°C and a relative humidity of ≤ 50 %:
Analog display: 2 %
Digital display: 0,15 %
Analog output: 0,3 %
Digital output: 0,15 %
- ± 1 digital interval
- 255 x 235 x 120 mm (W x D x H)
- Resistant plastic

TESATRONIC TT 80 and TT 90 Probe Display Units

High resolution display units

Combined analogue/digital display

Two probe inputs for single, sum and difference measurements.

In addition to TESATRONIC TT60 functions, TT 80 has the following additional functions:

- 9 measuring ranges with digital steps of 0,01 µm or 0.000001 in.
- Memorisation of extreme values "max.", "min.", "max. minus min." as well as the mean of the two values "max." and "min."
- Dynamic measurement with acquisition of more than 10 single values per second.
- Classification of measured values with a contact relay providing output signals for 5, 10, 20 or 40 acceptable classes.
- Analogue output for external processing of signals.

In addition to TESATRONIC TT60 functions, TT 90 has the following additional functions:

- 9 measuring ranges with digital step of 0,01 µm or 0.000001 in.
- Memorisation of extreme values "max.", "min.", "max. minus min." plus the mean of both values "max." and "min."
- Dynamic measurement with acquisition of more than 10 single values per second.
- Classification of measured values with output signals through contact relay for 5, 10, 20 or 40 acceptable classes.
- Analogue output for external signal processing.
- Output for bolt retraction control.
- Selection of stabilisation time for measuring cycles.
- RS digital output for values to the micron.



TT 90



TT 80



Application: TT 80 with a SIP (Société genevoise d'instruments de physique) high precision measuring bench

No	=		
		Measuring range zoom x5	Memory
04430011	TESATRONIC TT80 High precision electronic display	-	●
04430012	TESATRONIC TT90 High precision electronic display	-	●

=		
	Number of probes inputs	Automatic conversion of range
TESATRONIC TT80 High precision electronic display	2	●
TESATRONIC TT90 high precision electronic display	2	●





DELIVERED WITH THE FOLLOWING ACCESSORIES:

04761054	Battery charger 100 ÷ 200 VAC / 50 ÷ 60 Hz, 6,6 V DC, 750 mAh, supplied without power cable
04761055	Mains cable EU for charger 0471054

OPTIONAL ACCESSORIES:

04768000	Hand switch for manually triggering data transfer. Jack plug connector, 1,8 m - TESA SPC PRINTER printer - TESATRONIC TT display units
04768001	Foot switch for triggering data transfer. Jack plug, 1,8 m - TESA SPC PRINTER printer - TESATRONIC (TT) display units
04761062	Opto-USB cable, Duplex, 2m Bidirectional communication
04761049	Opto-RS cable, Duplex, 2m Bidirectional communication

 For a temperature of 20°C and a relative humidity of ≤ 50 %: Response time analogue, digital and LED displays classification: ≤ 100 ms. Holding of digital display: 100 ms. Response time of the analogue output signal in relation to analogue display: ≤ 30 ms.

 For a temperature of 20°C and a relative humidity of ≤ 50 %: Zero drift and signal amplification: ≤ 0,005 %/°C. No drift of stored values. Frequency limit for all displays frequency, analog output and memory in relation to input signal: 10 Hz

 RS232 opto-coupled output

 Voltage range of ± 2 V to ± 10 V. Output current: ≤ 2 mA. Load adjustment: ≥ 5 kΩ. Background noise (probe to 0 electric) ≤ 1 mV. Reference potential: analog ground 0 V

 6,5 Vdc up to 7,3 V DC. Consumption: 2 W. Monitored voltage fluctuation. Supply voltage for probe: 3 V

 0°C to 60°C

 -10°C to 70°C

 80 %, without condensation

 Protection of frontal face: IP54 (IEC 60529, DIN 40 050)

 IEC/EN 61326-1 USA: CFR47, Part 15, Subpart B, Class B, Digital Device

 1,1 kg

 Transport packaging

 Identification number

 Declaration of conformity



TESATRONIC TTA20 Probe Display Unit

Compact design with analogue indication and value classification of measured values.

Aluminium housing, designed for shop floor applications, user-friendly.

- Easy-to-read analogue display with mirror strip in order to avoid parallax error.
- 6 measuring ranges.
- Metric/Inch conversion.
- Zero setting potentiometer for display.
- 2 probe inputs for single, sum or difference measurements.
- 1 auxiliary signal input, e.g. for all correction values.
- Colour LEDs of green for "Good", yellow for "Rework" and red for "Scrap".
- Potentiometer for setting limit tolerances.
- Polarity reverse switch for classification signals (internal or external dimensions).
- Switch for locking or unlocking a displayed value.
- Analogue output for a display unit or external recording.



TTA20

- DIN 32876 Part 1
- Length: 100 mm
- Limit value for a temperature of 20°C and a relative humidity of ≤ 50 %: Analog Display: 1,5 % Analog output: 0,3 %
- Display: negligible. Classification signals: 5 %
- 258 x 190 x 158 mm (W x D x H)
- Die-cast aluminum case, designed for the workshop
- For a temperature of 20°C and a relative humidity of ≤ 50 %: Response time of the analogue display: ≤ 1 ms. Response time of the analogue output signal from the analog display: 20 ms. Response time for classification signals: 10 ms.
- For a temperature of 20°C and a relative humidity of ≤ 50 %: Zero drift: ≤ ± 0,005 % /°C. No drift of stored values. Frequency limit for analogue display: 1 Hz. Frequency limit for analogue output: 50 Hz. Frequency limit for classification: 30 Hz

No	=	Number of measuring ranges Min range / Max range max (µm)	Measuring range zoom x5	Memory	Power supply
04430003	TTA20	6 / min ± 3 max ± 1000	-	-	Network

DELIVERED WITH THE FOLLOWING ACCESSORIES:

03160015	Mains cable CH 2 m
03160016	Mains cable, EU, 2 m
03160017	Mains cable without plug, 2 m for TTA20

OPTIONAL ACCESSORY:

04460004	Connector 15 pins for analogue output and classification signal of TTA20
----------	--

µm	µm	in	in
± 1000	50	± 0.1	0.005
± 300	10	± 0.03	0.001
± 100	5	± 0.01	0.0005
± 30	1	± 0.003	0.0001
± 10	0,5	± 0.001	0.00005
± 3	0,1	± 0.0003	0.00001

Number of probe inputs	Automatic conversion of range
2	-



Accessories for TESATRONIC TT Units



04761055



04761056



04761054



03160017



03160015



03160016



Template for TT10 display

Voltage: ± 1 V. Output current ≤ 3 mA. Adjustment load ≥ 2 k Ω . Residual ripple (at electrical zero): ≤ 1 mV. Reference potential: analogue ground 0 V

Supply voltage 230 or 115 V -10% to +20%, 50-60 Hz. Virtual power: 20 VA. Supply voltage for probe: 1,5 Vrms -10% to +5%. Frequency: 13 kHz $\pm 0,5$ %.

0°C to +50°C

-10°C to +70°C

Level of protection: IP40 (IEC 60529)

EN 50081-1
EN 50081-2
EN 50082-1
EN 50082-2

3,4 kg

Transport packaging

Identification number

Declaration of conformity

No

=

04761054	Battery charger 100 ÷ 200 VAC 50 ÷ 60 Hz, 6,6 V DC, 750 mAh supplied without power cable
04761055	Mains cable EU for charger 0471054
04761056	Mains cable US for charger 0471054
03160015	Mains cable CH, 2 m for TTA20
03160016	Mains cable EU, 2 m for TTA20
03160017	Mains cable without plug, 2 m for TTA20
04460007	10x templates for TT10
04460004	Connector 15 pins for analogue output and classification signal of TTA20
04768002	3 AA 1,5 V batteries, type LRC 6 for TT10





±2 mm, ±5 mm



0,1 µm



Field error indication (pictogram / text) to a temperature of 20°C and a relative humidity of ≤ 50 %: Digital output: ±(0,05 + 0,15 % of range)



55 x 172 x 155 mm (H x W x D)



Housing in aluminium



For a temperature of 20°C and a relative humidity of ≤ 50 %:
Zero drift: ≤ ± 0,05 %/°C.
Sensitivity drift: ≤ ± 0,05 %/°C.
Acquisition time: 10 ms (between two consecutive measurements) 1 ms (timing window) time data transfer of digital serial output (USB): depends on the operating system of the computer.



USB port (USB Hub) Communication: USB 2.0, 3 external ports (≤ 100 mAh)



Supply voltage of the charger: 115 to 230 Vrms, charger frequency 50 ÷ 60 -10 to +15 % Hz



10°C to 40°C



-10°C to 70°C



80 %, without condensation



IP40 (IEC 60529) (DIN 40050)



IEC/EN 61326-1 U.S. 47 CFR part 15, subpart B, Class B digital device



1 kg (BPX) 0,85 kg (TWIN Station)



Power supply 100 ÷ 240 V, 50 ÷ 60 Hz (04761054) EU Cable, CH (04761055) U.S. Cable (04761056)



Packed suitable for transport



Identification number



Declaration of conformity

ELECTRONIC INTERFACE UNITS

Electronic interfaces to manage, synchronize inductive probes and allow data transfer to a computer or an automatic inspection machine.

TESA Probe Interface Boxes - BPX Series

Modular system available in 2 versions (BPX and TWIN-STATION) for the conversion of measured signals to digital values and transmission of these values to a computer. These units are key components for multigauging inspection fixtures for centralised process control systems.

Signal inputs – 1 to 4 TESA standard half-bridge probes.

Signal output – digital, RS232 through USB port.

- Direct connection to the computer's USB port.
- Stand Alone operating mode: program routine via the computer, enabling the BPX box to execute a simple measuring function with classification signal relay via connector Sub-D 15P.
- Optimal adaptation for various measuring applications, for example, connection of 16 probes thanks to serial USB connections on 4 BPX boxes.
- Increased functional reliability and high precision.
- Increased immunity to negative environmental effects, whether of electrical origin or provoked by liquid and solid contaminants.
- BPX is compatible and can be used with TWIN-STATION.
- TIS interface software is included in the BPX (part number 05030012) for display of measured values. Possibility of indicating tolerance values, and simple functions +A, -A, +A+B, +A-B, export of values to a .csv file.



BPX Front



BPX Rear

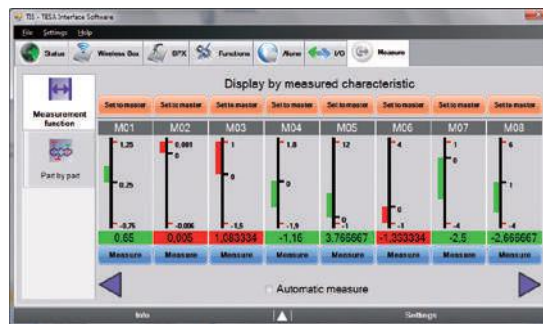

TIS software included in the BPX supply



05030010



Number of probe inputs

4



Number of I / O (In / Out) controllers

1 / 3



Connector

Sub-D 15 p/f (for In/ Out signals)



TWIN-STATION Receiver for TESA Wireless Probes



GTL 21 W wireless probe with VERIBOR (optional)

Modular system available in 2 executions (TWIN Station and BPX) for the conversion of inductive probe signals into digital values for transmission to a computer. These units are important components for measuring fixtures requiring freedom of movement without any constraints and without any cables, a wireless transmission

Signal inputs – 1 to 8 TESA half-bridge wireless probes*

Signal outputs – digital, RS232 through USB port

- Direct connection to the USB port of the computer.
- Perfect fit for your metrology applications through the connection of up to 32 wireless probes by means of serial USB to 4 TWIN-Station units.
- Great functional reliability and high accuracy.
- TWIN Station is compatible and can be used with BPX.
- TIS interface software TIS included in supply of TWIN-STATION (part no. 05030012): display of measured values. Possibility of indicating tolerances, simple functions +A, -A, +A+B, +AB, and export of values to a .Csv file.

Note: The sale of TWIN-STATION is limited to EU countries, Switzerland, USA and Canada.

* The sale of wireless probes is limited to EU countries, Switzerland, USA, Canada and China.



TWIN Station, front



TWIN Station, rear

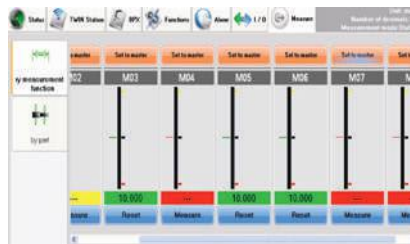

TIS Software, included in the Twin Station supply

- ± 2 mm, ± 5 mm
- 0,1 µm
- For a temperature of 20°C and a relative humidity of ≤ 50 %: Digital output: ± (0,05 + 0,15 % of measuring range)
- 55 x 172 x 155 mm (H x W x D)
- Housing case in aluminium
- For a temperature of 20°C and a relative humidity of ≤ 50 %: Zero drift: ≤ ± 0,05 %/°C. Sensitivity drift: ≤ ± 0,05 %/°C. Acquisition time: 20 ms (between two consecutive measurements) 2 ms (timing window) Time for data transfer from digital serial output (USB): depends on the operating system of the computer
- Power supply via USB cable connection – directly to PC (USB port) – to a USB-connected hub – to a BPX probe interface (05030010)
- 10°C to 40°C
- 10°C to 60°C
- 80 %, without condensation
- IP40 (IEC 60529) (DIN 40050)
- IEC/EN 61326-1 U.S. 47 CFR part 15, subpart B, Class B digital device
- 0,85 kg
- USB cable, 1,80 m
- Transport packaging
- Identification number
- Declaration of conformity

	Number of wireless probes per TWIN Station	Power supply	Weight, kg
05030012	1-8	Power supply via: – USB port of PC – USB-connected hub – BPX	0,85



± 0,5% with reference to the measuring span



± 10 to ± 15 V DC, 60 mA



≤ ± 100 ppm/°C, stability at zero = ≤ ± 0,2 μm/°C



15°C to 40°C



-10°C to 70°C



30% to 80 %, without condensation



IP50 (IEC 60529)



Transport packaging

TESA Probe Interface Boxes with Analogue Output – Series M4P-2

Signal inputs – TESA standard execution probes (Half-bridge)

Signal outputs – analogue (in ± V/mm)





- Connection of up to 32 TESA standard half-bridge probes.
- Connection possible to a PC through the A/D transducer.



Rack with 3 M4P-2 interfaces



Multi-gauging fixture with 1, 2 or 4 M4P-2 interfaces

No	=					
		Sensitivity (mV / V / mm)	Number of probe inputs	Dimensions (mm)	Analogue outputs	Weight (kg)
S48001721	M4P-2 interface 4 probe inputs with demodulator and analogue output in V/mm	73,75	4, including a demodulator	36 x 100 x 120	± 1 V/mm, ± 2,5 V/mm, ± 5 V/mm, ± 10V/mm	0,6
S48001722	R2M-1 rack for 2x M4P-2	–	8 (with 2x M4P-2)	55 x 212 x 144	–	0,9
S48001723	R4M-1 rack for 4x M4P-2	–	16 (with 4x M4P-2)	160 x 212 x 144	–	1,2
S48001724	Supply module MA4-2, 230V	–	Voltage: 230 ± 10 % Vac, 50 Hz	85 x 222 x 146	Output voltage: ± 15V for 32 probes	1,1
S48001731	Power supply MA4-2, 110 V	–	Voltage: 110 ± 10 % Vac, 60 Hz	85 x 222 x 146	Output voltage: ± 15V for 32 probes	1,1

Accessories for M4P-2 probe interface

No	=
S48001725	M4P-2 connecting cable to PC, 2m DB-37 pins m/f



Adaptor Cable: DIN 5p Connector to USB Type A Connector

Allows for quick and easy connection of any TESA standard half bridge probe to a PC USB port.

Signal inputs – TESA standard probes (Half-bridge)

Signal outputs – digital RS 323 through USB port

No	=			
		Measuring range, mm	Deviation span of indication	Zero drift
03260500	Cable adapter DIN 5p for USB. enables connection of TESA probes sensitivity 73,75 mV/V/mm directly to a USB port	± 2 mm	0,3 % ± 0,1 µm	± 0,01 %/°C
03260501	Cable adapter DIN 5p for USB. enables connection of TESA probes sensitivity 29,50 mV/V/mm directly to a USB port	± 5 mm	0,3 % ± 0,1 µm	± 0,01 %/°C



Cable adapter: DIN 5-pin connector to USB connector type A



DIN 32876 Part 1



0.1 µm



2 V effectively
13 kHz ± 0,5 %



At 20°C and relative humidity ≤ 50 %:
error of indication = 0,3 % ± 0,1 µm zero drift ± 0,01 %/°C V.
Standard refresh speed = 80 ms.
Maximum refresh speed = 42 ms.
Distance between the stops and the electrical zero cannot be adjusted.
Length of cable: 1,2 m. Note: the total error should take into account the error of the probe and the error of the adapter.



USB 2.0 RS232, virtual COM port



See table



20 ± 0,5°C



10°C to 40°C



80 %



IP51 (IEC 60529)



Packed suitable for shipping



Serial number identification



Calibration Standards – Dummy Probes

Calibration standards – also known as "dummy probes" – are resistance dividers. Each calibration standard simulates a given length dimension with high accuracy. Each calibration standard has 2 values (positive and negative). The values indicated below are the nominal values.

These products are calibrated and supplied with an inspection report that shows the values (actual values) measured during calibration and the related measuring uncertainty.

The calibration standards are connected to the instrument in place of regular probes. For the calibration and all required setting operations of the instrument, certain criteria and conditions need to be respected. Consult the user manual or get in touch with our specialists for further information.



Set of 3 calibration standards (S41077249)



Input impedance
 $970 \pm 50\Omega$ (13 kHz)
 or $2150 \pm 50\Omega$
 (standard $0 \mu\text{m}$)
 Phase (13 kHz):
 $71 \pm 2^\circ$. Input
 resistance:
 $100 \pm 5\Omega$. Output
 impedance at
 13 kHz: $1000 \pm 2\Omega$.
 Phase (13 kHz): $0,2^\circ$
 Dummy probe (half-
 bridge), sensitivity
 $73,75 \text{ mV/V/m}$.
 Suitable for
 instruments with
 following features:
 Frequency: 13
 $\pm 0,65 \text{ kHz}$, Voltage:
 $3 \pm 0,015 \text{ Veff}$ (2
 symmetrical voltages
 of $1,5 \text{ Veff}$) Input and
 output impedance:
 $\leq 0,2\Omega$ et 2000Ω ,
 respectively



-10°C to 70°C



10°C to 35°C



Calibration: 40 % to
 60 %. Operating:
 20 % to 80 %.
 Storage: 5 % to
 95 %. Without
 condensation.



IP40 (IEC 60529)



Inspection report



$\emptyset 18 \text{ mm}$, length
 118 mm



$\approx 45 \text{ g}$



$20 \pm 0,5^\circ\text{C}$, stabilisa-
 tion time = 8 h



$\pm 3 \text{ ppm}/^\circ\text{C}$. Ageing:
 $\pm 30 \text{ ppm/a}$

No

=

Value of the calibration stan-
 dard (microns)

S41078077	Dummy probe	± 0
S41078079	Dummy probe	± 3
S41078228	Dummy probe	± 100
S41078230	Dummy probe	± 190
S41078087	Dummy probe	± 300
S41078332	Dummy probe	± 500
S41078751	Dummy probe	± 1000
S41078752	Dummy probe	± 1900
S41077249	Set of 3 dummy probes	$\pm 0 / \pm 100 / \pm 1000$
S41078654	Set of 2 dummy probes	$\pm 190 / \pm 1900$



INSERTS FOR AXIAL PROBES, WITH M2 THREAD

Extensions for Inserts with M2 Thread

No		L, mm
03540505		10
03540506		15

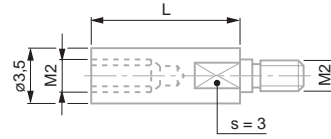

03540505, 03540506

Measuring Insert with Cylindrical Measuring Face, Lock Nut for Radial Alignment, M2 Thread

No			L, mm
03510503	Carbide		6

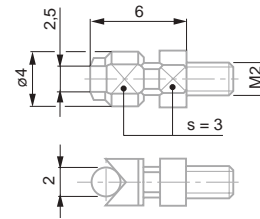

03510503

Hemispherical Measuring Inserts, M2 Thread

No				R, mm	Material	L, mm
03510204				R 1	Carbide	3
03510103				R 5	Carbide	3

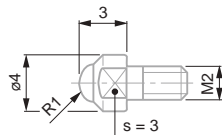

03510204

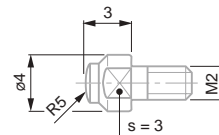

03510103

Spherical Measuring Inserts, R = 5 mm, M2 Thread

No			L, mm
03510202	Carbide		16
03510203	Carbide		26

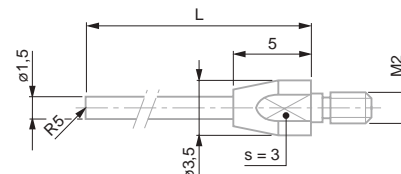

03510202, 03510203



INSERTS FOR AXIAL PROBES, WITH M2,5 THREAD

Extensions for Measuring Inserts, Ø 4 mm, 10 – 40 mm

No	L, mm
03540501	10
03540502	15
03540503	20
03540504	40

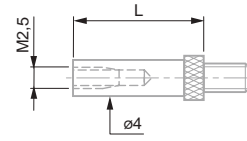

03540501 to 03540504

Standard Spherical Measuring Inserts, R = 1,5 mm, L = 6 mm

No	L, mm	Material	R, mm
03510001	L=6 mm	Steel	6
03510002	L=6 mm	Carbide	6
03560001	L=6 mm	Sapphire	6

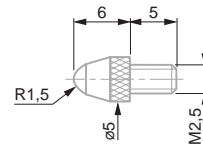

03510001, 03510002, 03560001

Spherical Measuring Insert with 4 Interchangeable Pins, R = 1,5 mm, Length 16-46 mm

No	Material	L, mm
03510201	Steel	16, 26, 36, 46

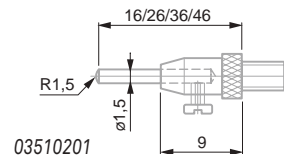

03510201

Spherical Measuring Inserts, R = 5 mm, L = 6 mm

No	Material	L, mm
03510101	Steel	6
03510102	Carbide	6

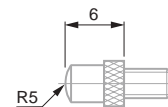

03510101, 03510102

Insert with Cylindrical Measuring Face, Counter Nut for Radial Alignment

No	Material	L, mm
03510502	Carbide	6

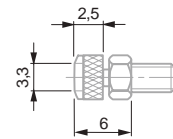

03510502

Spherical Measuring Inserts, R 1 – 8 mm, L > 18mm

No	Material	Ø, mm
03560051	Carbide	1
03560052	Carbide	2
03560053	Carbide	3
03560054	Carbide	4
03560055	Carbide	5
03560056	Carbide	6
03560057	Carbide	7
03560058	Carbide	8

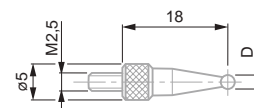

03560051 to 03560058



INSERTS FOR AXIAL PROBES, WITH M2,5 THREAD

Inserts with a Flat Measuring Face $\varnothing 1,5$ mm, Interchangeable Pin, Steel or Carbide

No	\varnothing	Material	L, mm
03560008	1,5	Steel	20
03560009	1,5	Carbide	20

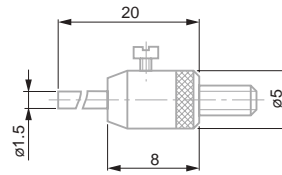

03560008, 03560009

Inserts with Flat Measuring Face, $\varnothing 2$ mm, Steel

No	\varnothing	L, mm	L1, mm
03560026	2	5	2,8
03560027	2	10	7,8
03560028	2	15	12,8
03560029	2	20	17,8

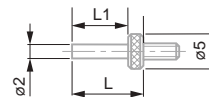

03560026 to 03560029

Insert with Offset (6,5 mm) Measuring Contact Point, Lock Nut for Radial Alignment

No	Material	L (offset), mm
03510401	Steel	6,5

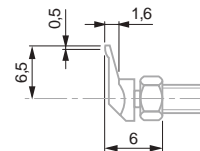

03510401

Inserts with a Flat Measuring Face, $\varnothing 2,5 - 3,4$ mm

No	\varnothing	Material	L, mm
03510801	2,5	Steel	6
03510802	2,5	Carbide	6
03560022	3,4	Steel	8
03560023	3,4	Carbide	8

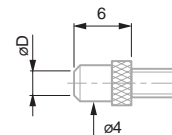

03510801, 03510802, 03560022, 03560023

Inserts with Flat Measuring Face, $\varnothing 5 - 10 - 20$ mm

No	\varnothing	Material	L, mm
03560012	5	Steel	5
03560013	5	Carbide	5
03560014	10	Steel	6
03560015	10	Carbide	6
03560016	20	Steel	3,6

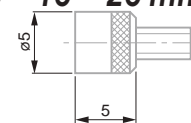

03560012, 03560013

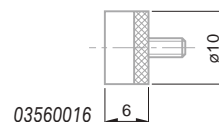

03560016

Insert with Off-centre (6,5 mm) Narrow Face, Lock Nut for Radial Alignment

No	Material	B (measuring face contact), mm
03510602	Carbide	0,5

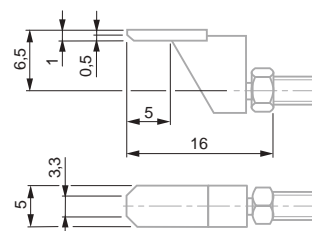

03510602



INSERTS FOR AXIAL PROBES, WITH M2,5 THREAD

Insert with a Flat Measuring Face, \varnothing 2,5 mm, Adjustable Parallelism, Counter-nut for Radial Alignment

03510902	2,5	Carbide	16

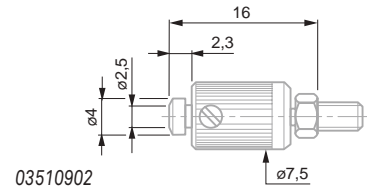

Insert with Offset (12 mm) Contact Point, Lock Nut for Radial Alignment

03560063	Steel	L (offset), mm	12

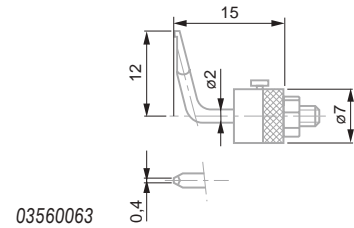

Insert with Narrow Measuring Face, Adjustable Parallelism, Counter-nut for Radial Alignment

03510702	Carbide	B, mm	0,5

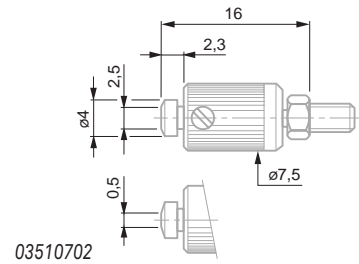

Inserts with Blade-shaped Measuring Face, Lock Nut for Radial Alignment

		L, mm	B (measuring face), mm
03560024	Steel	8	0,3
03560025	Carbide	8	0,3

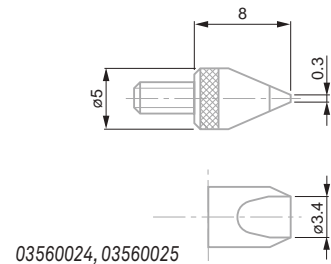

Measuring Inserts with Ball-bearing Rollers, Lock Nut for Radial Alignment

	Roller shape	L, mm	
03560010	Cylindrical	Steel	17,25
03560011	Domed	Steel	17,25

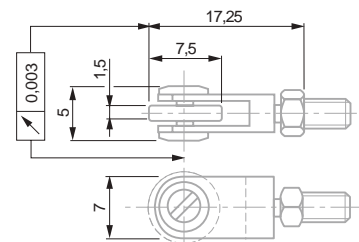

Insert with Needle Contact Point

03560030	

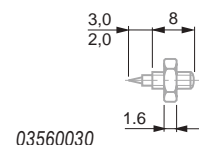

SPRING SETS, BELLOWS, CLAMPING ELEMENTS, MANUAL RETRACTION FOR AXIAL PROBES

Spring Sets for Axial Probes

No	=	Measuring force (N)
03260419	Spring sets for GT22	0,16
03260420	Spring sets for GT22	0,25
03260457	Spring sets for GT21/22	0,63
03260422	Spring sets for GT21/22	1,0
03260423	Spring sets for GT21/22	1,6
03260424	Spring sets for GT21/22	2,5



All values given in the table for the measuring force equal nominal values at electrical zero; max. deviation $\pm 25\%$. Valid for upright assembly position with downward oriented measuring bolt, and used in static measurement.



Plastic sleeve marked with force related data



Packed suitable for transport

Bellows for Axial Probes

No	=	
03260468	For 4,3 mm bolt travel GT 21, 22, GTL 21, 211, 22	Nitrile
03260470	For 4,3 mm bolt travel GT 21, 22, GTL 21, 211, 22	Viton
03260489	For pressure probe 4,3 mm bolt travel GTL 212, 222	Viton
03260491	For 10,3 mm bolt travel GT 27, 271, 28, 61, 611, 62	Viton
03260490	For pressure probe 10,3 mm bolt travel GT 272, 282, 612, 622	Viton

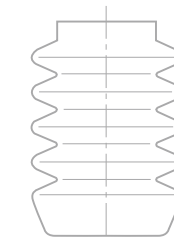

Protection bellow



Nitrile: resistant synthetic sealing for normal use. Viton: high-resistance synthetic sealing. Used in conditions where probes are permanently exposed to coolants and lubricants.



Packed suitable for transport

Clamping Elements for Axial Probes

Elements with 3 clamping faces – Prevents any deformation of the measuring bolt guiding system, thus preserving all the metrological properties of the probe.

No	=	∅	A mm
02611013	VKD clamping screw		M4
02611014	VKE clamping sleeve	∅ 8 mm	
01860401	Y61 fixing clamp	∅ 5,6 mm and ∅ 9,5 with dovetail	
02660048	VDE 28 probe holder	∅ 8 mm	



All dimensions to be noted are shown in the drawing.



Packed suitable for transport

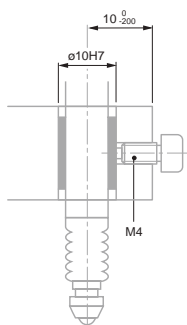

Fixing clamp for axial probe

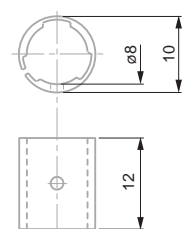

VKE – clamping sleeve

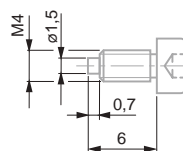

VKD – clamping screw

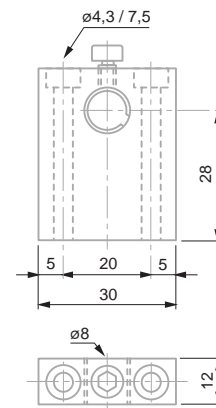

VDE – clamping élément with sleeve and clamping screw





Packed suitable for transport

Manual Measuring Bolt Retraction for Axial Probes

No	=	
03540104	TB 11 retraction device components	Consisting of: - 1 Washer TB102 (03540102) - 1 Lifting Lever TB101 (03540101)
03260401	Manual pneumatic retraction device.	Suitable for GT 22, 271, 28, 42, 44, 611, 62 – GTL211, 22 probes Consisting of: - 1 hand-operated vacuum pump - 1 tube of 1m, Ø 4,7 mm (ref. 03540405)
03540405	TB311 flexible tube	



Stainless steel measuring insert, carbide ball tip

Packed suitable for transport

ACCESSORIES FOR GT 31 LEVER PROBES

Probe Inserts for GT 31 Lever Probes

No	Ø	Lever – amplification	L, mm	A
03260402	1	1:1	32	One-piece shaft
03260410	2	1:1	32	One-piece shaft
03260403	3	1:1	32	One-piece shaft
03590002	1	1:1	32	Two-piece shaft
03590003	2	1:1	32	Two-piece shaft
03590004	3	1:1	32	Two-piece shaft
03590005	4	1:1	32	Two-piece shaft

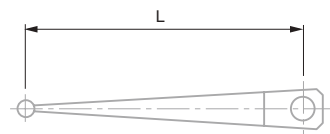

03260410



03260410



Packed suitable for transport

Fixing Bracket for TESA GT 31 Lever Probe

No	=	
03240100	Fixing bracket with dovetail clamp or cylindrical bore for GT31 probe	

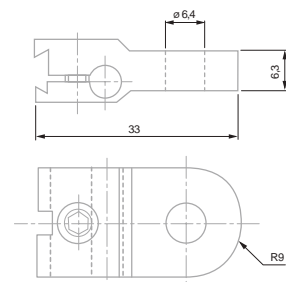

03240100



INSERTS WITH Ø 4 MM MOUNTING SHAFT, FOR FMS PROBES

Probe Inserts with a Flat Rectangular Face, Ø 4 mm Mounting Shaft for FMS Probes

No			L, mm
02660066	Carbide	12	
02660068	Carbide	25	
02660067	Carbide	12	
02660069	Carbide	25	

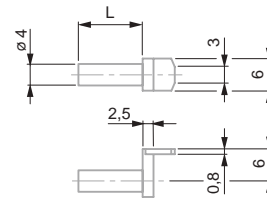

02660067, 02660069

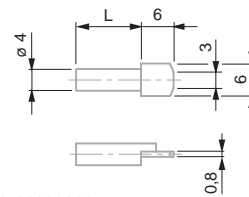

02660066, 02660068

Probe with 2 Cylindrical Measuring Faces with Ø 4 mm Mounting Shaft, for FMS Probes

No			L, mm
02660070	Carbide	20	
02660071	Carbide	40	
02660072	Carbide	60	
02660082	Carbide	40	
02660083	Carbide	60	

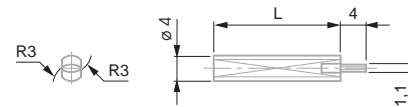

02660070, 02660071, 02660072

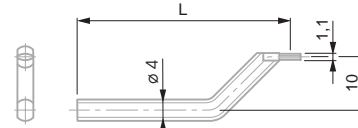

02660082, 02660083

Insert with Ø = 2 mm Diameter Contact Pin, Hemispherical Face with Ø 4 mm Diameter Mounting Shaft for FMS Probes

No			L, mm
02660074	Carbide	40	

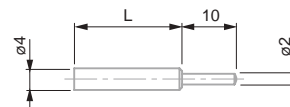

02660074

Probe with Ball Tip Ø 4 mm for FMS Probes

No			L, mm
02660076	3	Carbide	20
02660077	3	Carbide	40
02660078	3	Carbide	60
02660079	5	Carbide	20
02660080	5	Carbide	40
02660081	5	Carbide	60
02660084	5	Carbide	20
02660085	5	Carbide	33

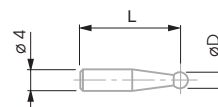

02660076 to 02660081

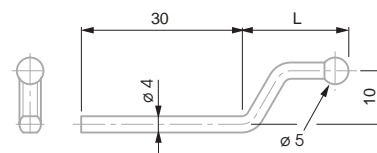

02660084, 02660085



Packed suitable for transport



Packed suitable for transport



Packed suitable for transport



Packed suitable for transport





Packed suitable for transport

INSERTS WITH Ø 6 MM MOUNTING SHAFT, FOR FMS PROBES

Inserts with Ball Tip, Ø 6 mm Mounting Shaft, for FMS Probes

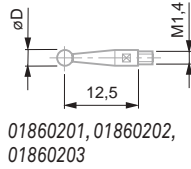

No	Ø	Material	L, mm
00760058	3	Carbide	55
00760059	5	Carbide	56
00760060	10	Carbide	55
01860201	1	Carbide	12,53
01860202	2	Carbide	12,53
01860203	3	Carbide	12,53
01860307	Wrench	-	-

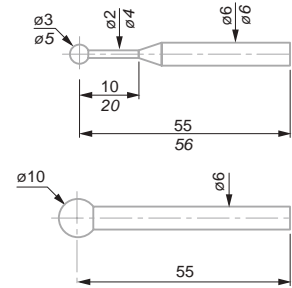

00760058, 00760059, 00760060



Packed suitable for transport

Barrel Shaped Inserts for Bores, Ø 6 mm Mounting Shaft, for FMS Probes

No	Ø	Material	Thread
00760066	2,2	Carbide	M3 to M16
00760067	4,5	Carbide	M6 to M48
00760068	9,7	Carbide	M12 to M150

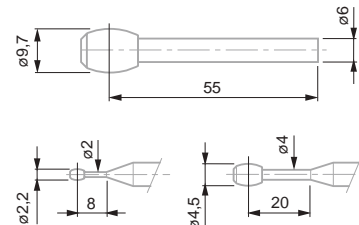

00760066, 00760067, 00760068



Packed suitable for transport

Disc Inserts for Grooves, Ø 6 mm Mounting Shaft, for FMS Probe

No	Ø	Material	Disc thickness, mm
00760074	4,5	Carbide	1
00760075	14	Carbide	2
00760076	19	Carbide	3

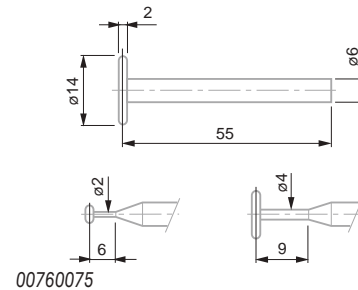

00760075

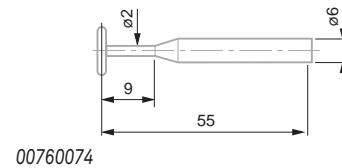

00760074



Transport packaging

Special Inserts, Ø 6 mm Mounting Shaft, for FMS Probes

No	Ø	Material	L, mm
00760082	2	Carbide	55

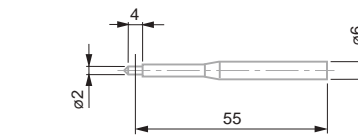

00760082



Packed suitable for transport

Universal Probe Holder with Ø 6 mm Mounting Shaft, for FMS Probes

No	Thread	L, mm
00760096	M1,4 and M2,5 threads	55

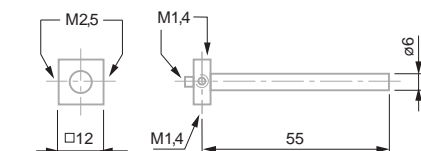

00760096



SPRINGS, PNEUMATIC ACTUATORS, HOLDERS, OFF-SET INSERTS, FOR FMS PROBE

Inserts with Offset Measuring Faces, for FMS Probes

No	=	A	Drawing
02630047	VBM offset insert	1	
02630048	VBN offset insert	2	
02630049	VBO offset insert	3	
02630050	VBP offset insert	4	
02630051	VBQ offset insert	5	

Inserts with offset faces for FMS probes

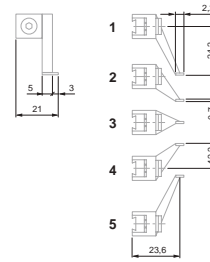

Packed suitable for transport

Fixed Holder, for FMS Probe

No	=	∅	A	A	Number	Position
02630042	VBH fixed holder	4	2	Horizontal		
02630043	VBJ fixed holder	4	1	Vertical		
02630045	VBK fixed holder	6	2	Horizontal		
02630046	VBL fixed holder	6	1	Vertical		

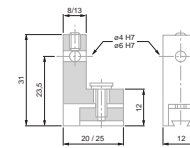

02630042
02630045

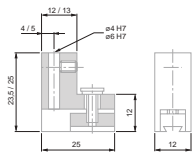

03230043
03230046



Packed suitable for transport

Holder with Fine Adjustment for FMS Probe

Helps greatly for setting a FMS probe.

Setting and locking screws remain accessible even when several probes are mounted side by side.

No	mm	∅	A	A	Number	Position
02630053	25	4	2	Horizontal		
02630055	25	4	1	Vertical		
02630052	25	6	2	Horizontal		
02630054	25	6	1	Vertical		

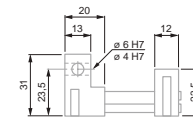

02630052
02630053

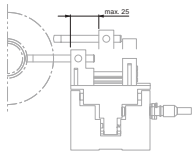

02630053



Holder width: 12 mm

Packed suitable for transport

Auxiliary Springs and Pneumatic Retraction Jack, for FMS Probe

No	=	Hand	N
03260440	Pneumatic jack	11 (for 4 bars)	
03260441	Spring element	0,4	
03260442	Spring element	0,63	
03260443	Spring element	1,0	
03260444	Spring element	1,6	
03260445	Spring element	2,0	
03260446	Spring element	2,5	
03260447	Spring element	4,0	

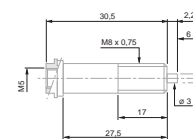

Pneumatic cylinder (jack) for FMS probe

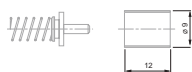

Auxiliary spring element for FMS probe



All values given in the table for the measuring force equal nominal values at electrical zero; max. deviation $\pm 25\%$. Valid for probing movements executed horizontally as well as in static measuring.

Packed suitable for transport

Spring Set with Specific Measuring Force, for FMS Probe

No	=	Hand	Measuring force, N
03260448	Spring set red	0,4	
03260449	Spring set yellow	0,63	
03260450	Spring set green	1,0	
03260451	Spring set blue	1,6	
03260452	Spring set brown	2,5	
03260453	Spring set black	4,0	

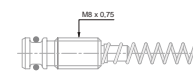

Spring set for measuring force for FMS probe



All values given in the table for the measuring force equal nominal values at electrical zero; max. deviation $\pm 25\%$. Valid for probing movements executed horizontally as well as in static measuring mode.

Packed suitable for transport



230 V 50 Hz



Packed suitable for transport

Maximum 20 probes type GT 22, GT 42 and GT 44, maximum force 0,63 N. Maximum 10 probes type GT 28 and GT 62, Maximum force 0,63 N.

(03260486) 3,5 kg

Electro-pneumatic Pump for Measuring Bolt Retraction

Electro-pneumatic vacuum pump, controlled by external switch (03260433): requires an automatic external command (e.g. instrument display).

No	=	A	
03260432	Electro-pneumatic vacuum pump with activation by connected foot switch	Electro-pneumatic vacuum pump. For the simultaneous retraction of a maximum number of 20 measuring bolts with a force up to 0,63 N	Activation by connected foot switch
03260433	Electro-pneumatic vacuum pump with activation by external control	Electro-pneumatic vacuum pump. For the simultaneous retraction of a maximum number of 20 measuring bolts with a force up to 0,63 N	Activation by external control



Electro-pneumatic vacuum pump



Packed suitable for transport

Connectors for Electro-pneumatic Pump for Measuring Bolt Retraction

No	=
03540403	T-connector for tube Ø 4,7 / Ø 2 mm (03540405)
03560000	Straight connector, M4 thread for tube Ø 4,7 / Ø 2 mm (03540405)
03560002	Angled connector, M4 thread for tube Ø 4,7 / Ø 2 mm (03540405)

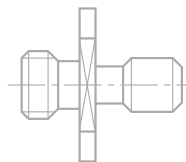

Straight connectors

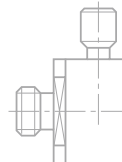

Angled connector

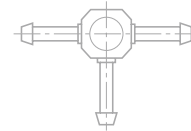

T-connector



Extension Cable for Probes, Lengths = 1 – 20m

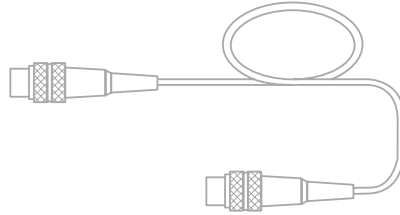

Cable extensions for TESA probes
DIN 453225, 5 pin connector



L, mm



It is recommended to calibrate equipment (probe + extension) connected together to ensure the highest accuracy.



Packed suitable for transport



Length, m (inch)

03240201

1m (3")

03240202

2m (6")

03240203

3m (9")

03240205

5m (32")

03240210

10m (49")

03240215

15m (65")

03240220

20m (16")



Optical Measurement



Software interface showing measurement data and graphs.

Label	Feature type	Description	Actual	Deviation	LSL	USL	Nominal
D01	Diameter / Average	Average Ø	26.534	0.024	-0.100	0.100	26.500
D02	Diameter / Average	Average Ø	26.531	0.261	-0.100	0.100	26.500
D03	Diameter / Average	Average Ø	25.885	-0.015	-0.100	0.100	25.900
D04	Diameter / Average	Average Ø	25.170	-0.021	-0.100	0.100	25.200
D05	Diameter / Average	Average Ø	23.475	-0.025	-0.100	0.100	23.500
D06	Diameter / Average	Average Ø	15.762	-0.008	-0.100	0.100	15.800



A COMPLETE RANGE OF MACHINES FOR NON-CONTACT MEASUREMENT

Optical measurement addresses the growing need to inspect parts faster, in a more accurate and repeatable way. The TESA range meets these requirements whilst adapting to the morphology of the parts to inspect.

- The TESA-SCAN profile-measuring machines for measuring round parts.
- The TESA-VISIO digital vision systems for a wide variety of machined, milled, cut, molded or stamped parts.
- Classic measurement through TESA-SCOPE profile projectors for immediate measurement results.





Diameter: 0,5 s
Length: 0,5 s



24 VDC



Dimension max. parts:
Ø 100 x L 300 mm
Weight max. parts:
4 kg



< 80 %



Packaging



Inspection report with a declaration of conformity



Scope: see TESA-REFLEX Scan software



H840 x L 1000 x P435 mm H33 x L39,5 x P17 in



103 kg



10°C to 40°C

TESA-SCAN 52 REFLEX-Click

This model includes the ultimate power of all TESA-SCAN machines, offering high technological performances combined with unmatched ease of use and exceptional price/quality relationship.

Thanks to the added functionality for automatic recognition of the parts to be measured, the REFLEX-Click mode allows them to be quickly and reliably inspected with a single click. The colour coded classification of the measured values enables the analysis of the measurement results at a glance, rendering part inspection especially easy to execute.

Another unique function available in the REFLEX-Click mode is the ability to measure lengths and diameters speedily, making the machine ideally suited for use on the shop floor.

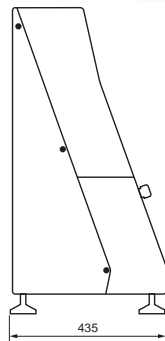
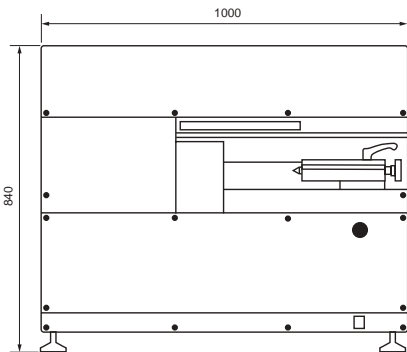

No	=
02430090	TESA-SCAN 52 fixed headstock
02430091	TESA-SCAN 52 rotary headstock

TESA-SCAN 52 REFLEX-Click	D	L	D	L	
	0,5 ÷ 52 mm	300 mm	0.02 ÷ 2.0 in	11.8 in	
	0,0001 mm	0,0005 mm	0.000004 in	0.00002 in	
	20°C ± 1°C	(2 + D/100) µm (D = mm)	(5 + L/100) µm (L = mm)	(0.08 + D/100) / 1000 in (D in mm)	(0.2 + L/100) / 1000 in (L in mm)
	2σ	1 µm	2,5 µm	0.00004 in	0.0001 in

Performances are based on the results obtained from clean, ground components measured at 20°C. They may be affected by the component shape and surface finish.



TESA-SCAN 25

Measuring machine with rotating work including:

- 1 rotary headstock
- 1 tailstock
- 2 male centers TL02-0001
- Comes with computer, mouse, operating system Windows 7 screen TFT 21.5" Multilingual, U.S. keyboard software Pro-Measure with manual FDE application on CD.



- Diameter : 0,5 s
Length : 0,5 s
- 100/110-220/240
VAC 50/60 Hz
- Max. workpiece size
(D x L): 59 x 270 mm;
Max. workpiece
weight: 2 kg
- < 80 %
-
- Shipping packaging
- Inspection report
with a declaration
of conformity
- Performances:
see Pro-Measure
software
- H800 x L640
x P500 mm,
H32 x L25 x P20 in
- 67 kg, 148 lbs
- 10°C to 40°C

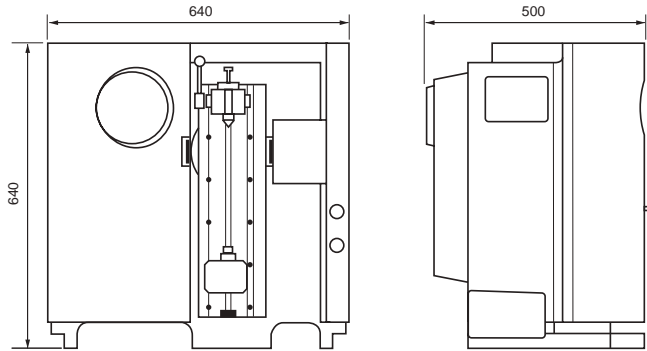

No **=**
02430000 TESA-SCAN 25

TESA-SCAN 25	D	L	D	L
	0,25 ÷ 25 mm	200 mm	0.01 ÷ 1 in	8.0 in
	0,0001 mm	0,001 mm	0.000004 in	0.00004 in
	20°C ± 1°C	(1,5 + D/100) µm (D = mm)	(0.06 + D/100)/ 1000 in (D = in)	(0.2 + L/100)/ 1000 (L = in)
	2σ	1 µm	0.00004 in	0.0001 in

Performances are based on the results obtained from clean, ground components measured at 20°C. They may be affected by the component shape and surface finish.



Diameter : 0,5 s
Length : 0,5 s

100/110-220/240
VAC 50/60 Hz

Max. workpiece size
(D x L): 100 x 290
mm. Max. workpiece
weight: 4 kg.

< 80 %



Shipping packaging

Inspection report
with a declaration
of conformity

Performances:
see Pro-Measure
software

H1055 x L800
x P580 mm,
H41 x L32 x P23 in

130 kg, 290 lbs

10°C to 40°C

TESA-SCAN 50

Measuring machine with rotating work including:

- 1 rotary headstock
 - 1 tailstock
 - 2 male centers TL02-0002
- Comes with computer, mouse, operating system Windows 7 screen TFT 21.5"
Multilingual, U.S. keyboard, software Pro-Measure with manual FDE on CD.

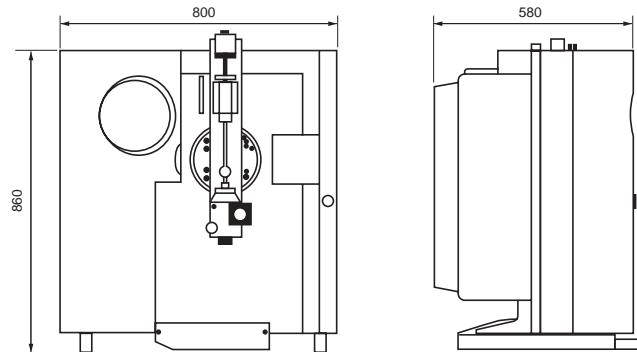

No **=**
02430010 TESA-SCAN 50

TESA-SCAN 50	D	L	D	L	
	0,5 ÷ 50 mm	275 mm	0.02 ÷ 1.96 in	10.8 in	
	0,0001 mm	0,001 mm	0.000004 in	0.00004 in	
	20°C ± 1°C	(2 + D/100) µm (D = mm)	(5 + L/100) µm (L = mm)	(0.08 + D/100)/ 1000 in (D = in)	(0.2 + L/100)/ 1000 (L = in)
	2σ	1 µm	2,5 µm	0.00004 in	0.0001 in

Performances are based on the results obtained from clean, ground components measured at 20°C. They may be affected by the component shape and surface finish.



TESA-SCAN 50 CE+

Measuring machine with workpiece rotation and tilt mechanism of the slide (30°) for thread measurement, base unit including:

- 1 rotary headstock
- 1 tailstock
- 2 male centers TL02-0002.
- Comes with computer with a mouse, 21.5" TFT screen Multilingual Windows 7 operating system, U.S. keyboard, Pro-Measure software with FDE implementation manual on CD.

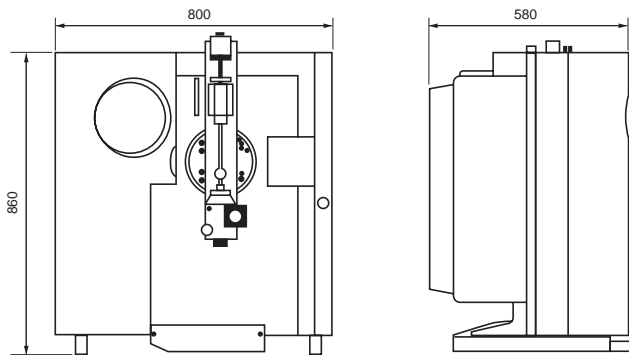
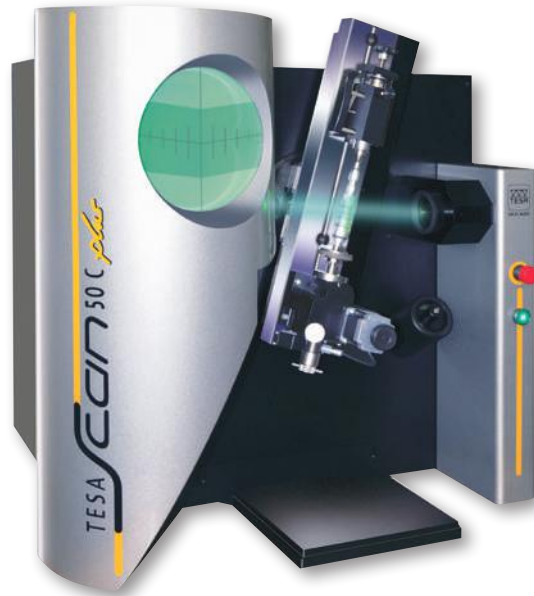

No = 02430030 TESA-SCAN 50CE+

TESA-SCAN 50CE+	D	L	D	L
	0,5 ÷ 50 mm	275 mm	0.02 ÷ 1.96 in	10.8 in
Tilting for thread measurement	Max. 30°			
	0,0001 mm	0,001 mm	0.000004 in	0.00004 in
20°C ± 1°C	(2 + D/100) μm (D = mm)	(5 + L/100) μm (L = mm)	(0.08 + D/100)/ 1000 in (D = in)	(0.2 + L/100)/ 1000 in (L = in)
2σ	1 μm	2,5 μm	0.00004 in	0.0001 in

Performances are based on the results obtained from clean, ground components measured at 20°C. They may be affected by the component shape and surface finish.

- Diameter : 0,5 s
Length : 0,5 s
- 100/110-220/ 240 VAC 50/60 Hz
- Max. workpiece size (D x L): 100 x 290 mm; Max. workpiece weight: 4 kg
- < 80 %
-
- Shipping packaging
- Inspection report with a declaration of conformity
- Performances: see Pro-Measure software
- H1055 x L800 x P580 mm, H41 x L32 x P23 in
- 140 kg, 310 lbs
- 10°C to 40°C





Diameter : 0,5 s
Length : 0,5 s

100/110-220/ 40
VAC 50-60 Hz

Max. workpiece size (D x L): 100 x 515 mm; Max. workpiece weight: 6 kg

< 80 %



Shipping packaging

Inspection report with a declaration of conformity

Performances: see Pro-Measure software

H1455 x L800 x P580 mm, H57 x L32 x P23 in

180 kg, 398 lbs

10°C to 4°C

TESA-SCAN 50+

Measuring machine with workpiece rotation and tilt mechanism of the slide (30°) for thread measurement, base unit including:

- 1 rotary headstock
- 1 tailstock
- 2 male centers TL02-0002
- Comes with computer with a mouse, 21.5" TFT screen Multilingual Windows 7 operating system, U.S. keyboard, Pro-Measure software with F-D-E implementation manual on CD.

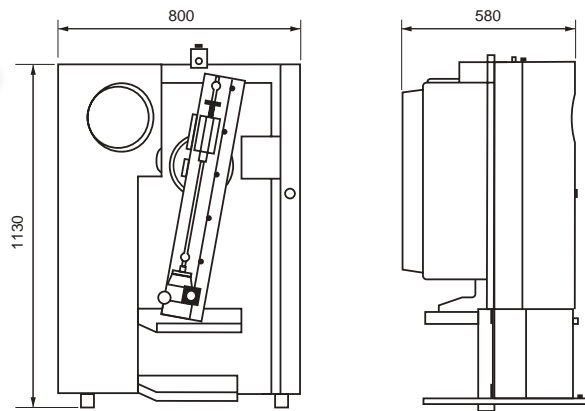

No =
02430040 TESA-SCAN 50+

TESA-SCAN 50+	D	L	D	L
	0,5 ÷ 50 mm	500 mm	0.02 ÷ 1.96 in	19.7 in
Tilting for thread measurement	Max. 15°			
	0,0001 mm	0,001 mm	0.000004 in	0.00004 in
20°C ± 1°C	(2 + D/100) μm (D = mm)	(5 + L/100) μm (L = mm)	(0.08 + D/100)/ 1000 in (D = in)	(0.2 + L/100)/ 1000 in (L = in)
2σ	1 μm	2,5 μm	0.00004 in	0.0001 in

Performances are based on the results obtained from clean, ground components measured at 20°C. They may be affected by the component shape and surface finish.



TESA-SCAN 80/ 80+

Measurement center with protection cabin, part rotation and tilt mechanism slide (TESA-SCAN 80 +) base unit including:

- 1 rotary doll
- 1 tailstock
- 2 male centers TL02-0002
- Delivered with computer with a mouse, 7 Multilingual Windows operating system already installed, screen, keyboard, software Pro-Measure/Pro-Composer with F-D-E implementation manual on CD.

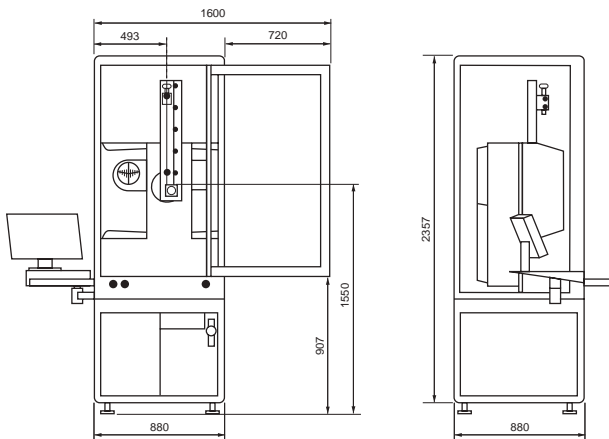

- 02430050 TESA-SCAN 80
- 02430060 TESA-SCAN 80+ with slew mechanism

- Diameter: 1 s
Length: 1 s
- 100/110-220/ 240 VAC 50/60 Hz
- Max. workpiece size (D x L): 100 x 515 mm; Max. workpiece weight: 6 kg
- < 80 %
-
- Shipping packaging
- Inspection report with a declaration of conformity
- Performances: see Pro-Measure software
- H 1500 x W750 x D 520 mm, H 60 x L 30 x P 20 in
- 250 kg (TESA-SCAN 80) 260 kg (TESA-SCAN 80+)
- 10°C à 35°C

TESA-SCAN 80/ 80+	D	L	D	L
	0,5 ± 80 mm	500 mm	0.02 ÷ 3.15 in	19.7 in
Tilting for thread measurement	Max. 10° (TESA-SCAN 80+)			
	0,0001 mm	0,001 mm	0.000004 in	0.00004 in
Max. tolerated error Ø < 30 mm	(1,5 + D/100) µm (D = mm)	(7 + L/100) µm (L = mm)	(0.06 + D/100)/1000 in (D = in)	(0.28 + L/100)/1000 in (L = in)
Ø > 30 mm (20°C ± 1°C)	(2 + D/100) µm (D = mm)	(8 + L/100) µm (L = mm)	(0.08 + D/100)/1000 in (D = in)	(0.35 + L/100)/1000 in (L = in)
2σ	0,001 mm	0,003 mm	0.00004 in	0.00012 in

Performances are based on the results obtained from clean, ground components measured at 20°C. They may be affected by the component shape and surface finish.



Fixturing Systems

Full range of standard fixturings, morse 1 (TESA-SCAN 25) and Morse 2 (TESA-SCAN 50, 52, 80).

No			Morse taper 1	Morse taper 2	
TL01-0002	Center adapter with a $\varnothing 6$ mm coupling bore		●	-	-
TL01-0003	2-jaw gripper		●	● Requires TL01-0027	External clamping for manual use
TL01-0004	2-jaw gripper		●	● Requires TL01-0027	External clamping for use with air pressure
TL01-0005	Raising blocks, in pairs		For TL01-0003 TL01-0004	For TL01-0003 TL01-0004	For external jaws H = 18
TL01-0006	Raising blocks, in pairs		For TL01-0003 TL01-0004	For TL01-0003 TL01-0004	For external jaws H = 22
TL01-0007	2-jaw chuck		●	● Requires TL01-0027	Internal clamping for manual use
TL01-0008	2-jaw chuck		●	● Requires TL01-0027	Internal clamping for use with air pressure
TL01-0009	External jaws, in pairs		For TL01-0003 TL01-0004	For TL01-0003 TL01-0004	$0 \div 6$ mm, T = 1.5
TL01-0010	External jaws, in pairs		For TL01-0003 TL01-0004	For TL01-0003 TL01-0004	$0 \div 6$ mm, T = 3
TL01-0011	External jaws, in pairs		For TL01-0003 TL01-0004	For TL01-0003 TL01-0004	$6 \div 12$ mm, T = 3
TL01-0012	External jaws, in pairs		For TL01-0003 TL01-0004	For TL01-0003 TL01-0004	$12 \div 18$ mm, T = 6
TL01-0013	External jaws, in pairs		For TL01-0003 TL01-0004	For TL01-0003 TL01-0004	$18 \div 24$ mm, T = 9







No	=		Morse taper 1	Morse taper 2	
TL01-0015	Internal jaws, in pairs		For TL01-0007 TL01-0008	For TL01-0007 TL01-0008	D = 4 ÷ 5 mm H = 6,6 mm
TL01-0016	Internal jaws, in pairs		For TL01-0007 TL01-0008	For TL01-0007 TL01-0008	D = 5 ÷ 6 mm H = 8,6 mm
TL01-0017	Internal jaws, in pairs		For TL01-0007 TL01-0008	For TL01-0007 TL01-0008	D = 6 ÷ 8 mm H = 11,5 mm
TL01-0018	Internal jaws, in pairs		For TL01-0007 TL01-0008	For TL01-0007 TL01-0008	D = 8 ÷ 11 mm H = 17,5 mm
TL01-0019	Internal jaws, in pairs		For TL01-0007 TL01-0008	For TL01-0007 TL01-0008	D = 11 ÷ 15 mm H = 20 mm
TL01-0020	Internal jaws, in pairs		For TL01-0007 TL01-0008	For TL01-0007 TL01-0008	D = 15 ÷ 19 mm H = 20,2 mm
TL01-0021	Set of external jaws, in pars		For TL01-0003 TL01-0004	For TL01-0003 TL01-0004	Set of jaws including: TL01-0009 TL01-0010 TL01-0011 TL01-0012 TL01-0013
TL01-0022	Set of interna jaws, in pairs		For TL01-0007 TL01-0008	For TL01-0007 TL01-0008	Set of jaws including: TL01-0015 TL01-0016 TL01-0017 TL01-0018 TL01-0019 TL01-0020
TL01-0026	Centre adapter with a 6 mm dia. coupling bore		-	●	-
TL01-0027	Reduction sleeve, Morese 2 to 1		-	●	-

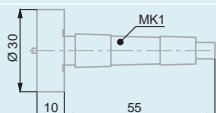
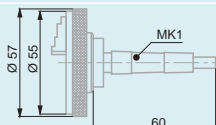
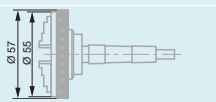
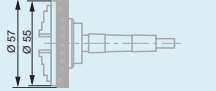
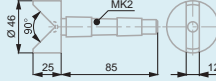
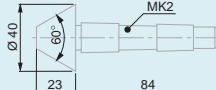
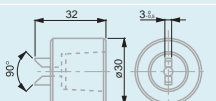

No			Morse taper 1	Morse taper 2	
TL01-0038	Exteranl jaws, in pairs		For TL01-0003 TL01-0004	For TL01-0003 TL01-0004	0 ÷ 6 mm, T = 6
TL01-0039	Exteranl jaws, in pairs		For TL01-0003 TL01-0004	For TL01-0003 TL01-0004	0 ÷ 6 mm, T = 15
TL01-0040	Exteranl jaws, in pairs		For TL01-0003 TL01-0004	For TL01-0003 TL01-0004	6 ÷ 12 mm, T = 15
TL02-0001	Extra male centre, 10 mm		●	–	2 items provided with TESA-SCAN 25 as standard
TL02-0002	Extra male centre, 17 mm		–	●	2 items provided ith TESA-SCAN 50, 52 and 80 as standard
TL02-0003	Drive centre		●	–	Diamond coated tip 10 mm
TL02-0016	Rotation centre with a B12 taper		●	–	Suitable for sleeves Z173-0922/0923
TL02-0017	Rotation centre, Morse 2		–	●	–
TL02-0018	Rotation centre with a B12 taper		–	●	–
TL02-0019	Rotation centre, Morse 1		●	–	–
TL02-0021	Rotation centre, Morse 2		–	●	–
Z173-0908	Vertical support		For TL01-0003 TL01-0004 TL01-0007 TL01-0008	For TL01-0003 TL01-0004 TL01-0007 TL01-0008	Ensures stable positioning for mounting jaws
Z173-0920	Female centre, Ø 10 mm		● Requires TL01-0002	● Requires TL01-0026	–
Z173-0921	Female centre, Ø 20 mm		● Requires TL01-0002	● Requires TL01-0026	–
Z173-0922	Female centre, Ø 10 mm		● For TL02-0016	–	B12 interior taper
Z173-0923	Female centre, Ø 20 mm		● For TL02-0016	–	B12 interior taper

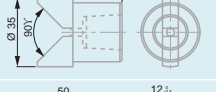
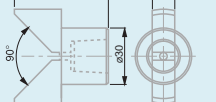

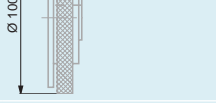
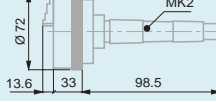
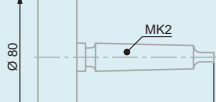
No	=		Morse taper 1	Morse taper 2	
Z173-0961	Platten, Ø 30 mm		●	-	-
Z173-2020	3-jaw chuck		●	● Requires TL01-0027	Clamping capacity: Outside 1 ÷ 15 mm, Inside 11 ÷ 26 mm
Z173-2024	6-jaw chuck		-	●	-
Z173-2025	6-jaw chuck		●	-	-
Z178-0607	Female centre		-	●	Ø 40 mm
Z178-0610	Male centre, Ø 15 ÷ 40 mm		-	●	-
Z178-0940	Female centre with a B12 internal taper		-	● Requires TL02-0018	Ø 10 mm
Z178-0941	Female centre with a B12 internal taper		-	● Requires TL02-0018	Ø 30 mm
Z178-0942	Female centre with a B12 internal taper		-	● Requires TL02-0018	Ø 45 mm
Z178-2009	Drive mechanism		-	●	Used to drive components between fixed centres. Directly fitted on the headstock
Z178-2020	3-jaw chuck. 2 ÷ 50 mm		-	●	Clamping capacity: Outside 2 ÷ 50 mm, Inside 23 ÷ 50 mm
Z178-2025	Platten, Ø 80 mm		-	●	-
Z178-2026	Drive centre		-	●	Diamond coated tip
Z178-3028	Drive centre, Ø 42 mm max.		-	●	-





SOFTWARE FOR PROFILE MEASURING MACHINES

Equipped with TESA-REFLEX Scan software, the TESA-SCAN 52 is robust and easy to use, and therefore perfect for use in workshops. Close at hand to operators, it replaces conventional measuring systems, including multigauging systems, offering unmatched flexibility and significant time savings.

Featuring an ergonomic interface and offering a large number of dimensions that can be measured, Pro-Measure retains the philosophy of TESA-REFLEX Scan software whilst providing greater capacity for the most advanced of measuring applications.

TESA-REFLEX Scan Software

Key Features :

- Automatic measurement of lengths and diameters using the REFLEX-Click function.
- Automatic recognition of the parts being measured or the programmes used.
- Intelligent detection of the relevant measurement zones.
- Management of the operator and programming modes.
- Value storage.
- Dynamic displaying of the measurement results.
- Flexible reporting.

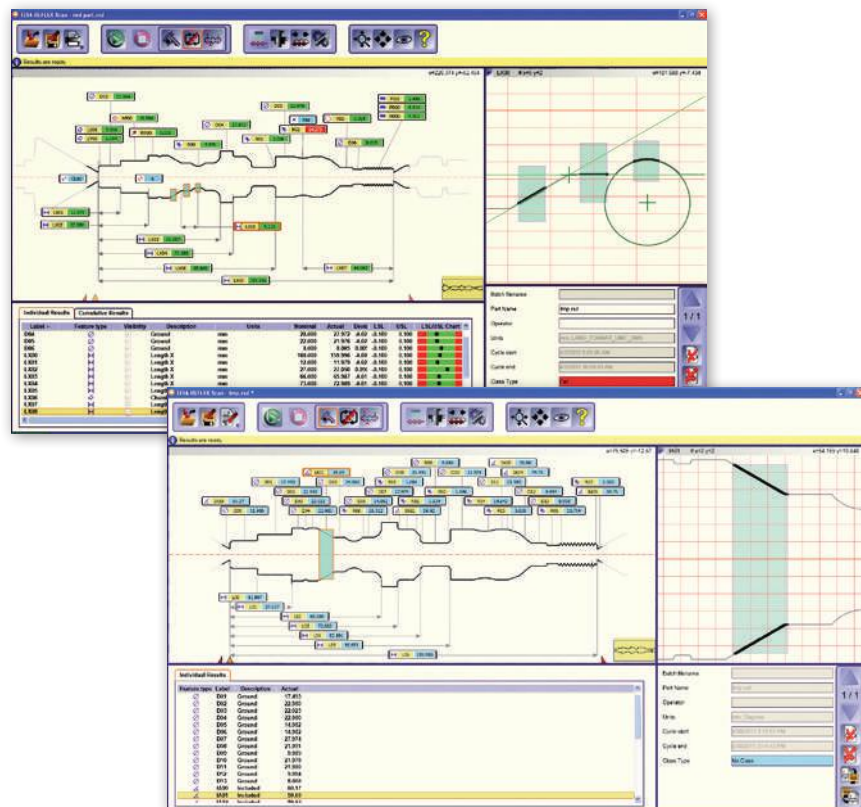

02460100

TESA-REFLEX Scan



Pro-Measure Software

Key Features:

- Rapid creation of programmes.
- Wide variety of measuring functions.
- Statistical follow up for optimum monitoring of the manufacturing process.
- Control of access for different user levels.
- Flexible reporting.

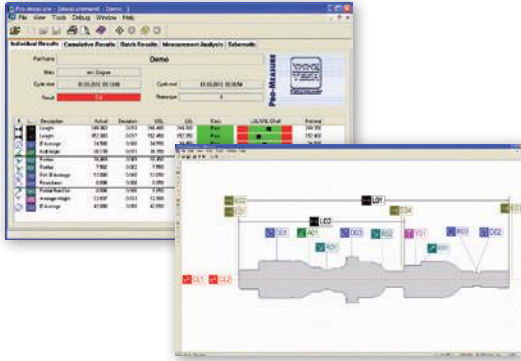

Taper threads

- Pitch
- Flank angle
- Included angle
- Gauge length
- Usable thread length
- Pitch diameter
- Major diameter

No	=
02460011	Pro-Measure
02460076	Option Pro-Measure for off-line programming

Conicity on diameter Thread and worm thread measurement With mechanical slewing

Main Features:

Parallel threads

- Major diameter
- Flank diameter
- Pitch
- Minor diameter
- Flank angle
- Root radius
- Crest radius
- Circularity
- Lead error

Taper threads

- Pitch diameter
- Major diameter
- Minor diameter
- Taper
- Crest diameter

Double-threads, parallel

- Major and minor diameters
- Half pitch
- Flank angle
- Crest radius
- Root radius

Worm threads (on request)

- Pitch
- Major and minor diameters
- Over Wire diameter
- Tooth thickness
- Pressure angle
- Addendum
- Dedendum
- Thread depth
- Runout

• Ball screws (on request)

- Pitch
- Lead error
- Over wire diameter

Static measurement

Diameters, lengths, intersection points, gauge diameters, radii, angles etc. 2D workpiece alignment – Creation of a workpiece axis based on two datum diameters.

Dynamic measurement

Concentricity – Parallel or interrupted diameters, tapers, parallel thread profiles or on maxi form.

Runout – Plain or interrupted diameters.

Diameters with rotation, ovality, max, min and average diameters of plain or interrupted diameters.

Hexagonal – Across-flats, symmetry of flats to axis, max. dimension across corners.

Section analysis with rotation – Longest and shortest section of radii, angular location.

3D workpiece alignment – Creation of a workpiece axis with reference to plain diameters or thread lengths.

Thread measurement – With no mechanical slewing

Main Features:

Parallel, vee-shaped threads

- Major diameter
- Flank diameter
- Flank angle
- Pitch



TESA-VISIO 200 GL



MPEX, Y* (EX, EY)
= (2 + 10 L/1000)
µm MPEXY* (EXY)
= (2,9 + 10 L/1000)
µm MPEZ** (EZ) =
(2,9 + 10 L/1000) µm
* L in mm
** Mechanical

precision with no
displacement in X-Y



Opto-electronic
measuring systems
with incremental
glass scales, resolu-
tion to 0,05 µm



Rigid granite
structure



100 ÷ 240 VAC
± 10 %; 50 ÷ 60 Hz



Max. load capacity:
10 kg



10°C to 40°C



80 %, non-condensing



Shipping packaging
(W x D x H) : 800 x
1200 x 1100 mm



Calibration
certificate



Declaration
of conformity



Manual



Measuring volume
(X/Y/Z) : 200 x 100
x 150 mm



Table surface (X/Y):
400 x 280 mm



Delivered fully
assembled



98 kg



Display resolution:
0,001 mm



20°C ± 1°C

Optics

Available with a manual indexable zoom or a motorised zoom for greater comfort. Also provided with a CCD colour camera.

Light illuminations

All light sources are fitted with LEDs producing a cold light, also long-lasting.

- Diascopic illumination for checking profiles as well as for transparency-based measurements.
- Ringlight (4 x 90°) for millings, bores, chamfers and round edges.
- Coaxial light for blind bores and cylindrical parts.
- Each light source can be set separately over the software.

Swiss mechanics

Granite structure to ensure the rigidity and stability required for any high-precision measuring system.



No	=		0.01	❄️	❄️
06830401	TESA-VISIO 200 manual zoom	200 x 100 x 150 mm (X/Y/Z)	MPE _{x,y} (Ex, Ey) = (2 + 10L*/1000) MPE _{xy} (Exy) = (2,9 + 10L*/1000) MPE _z (Ez) = (3,9 + 10L*/1000) *L = mm	Manuals	4 x 90°
06830428	TESA-VISIO 200 motorised zoom	200 x 100 x 150 mm (X/Y/Z)	MPE _{x,y} (Ex, Ey) = (2 + 10L*/1000) MPE _{xy} (Exy) = (2,9 + 10L*/1000) MPE _z (Ez) = (3,9 + 10L*/1000) *L = mm	Manuals	4 x 90°

OPTIONAL ACCESSORIES:

06860030	Lens 0,5x
06860031	Lens 0,75x
06860032	Lens 1,5x
06860033	Lens 2x
06860145	Collimated light
06860186	Foot pedal for TESA-VISIO manual
06860187	TESA-REFLEX Vista Compare
06860400	Base kit
06860401	Advanced kit
06869122	PLASTIFORM Full case

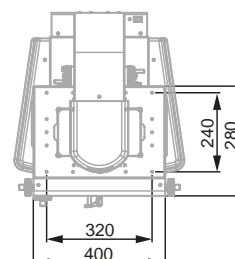
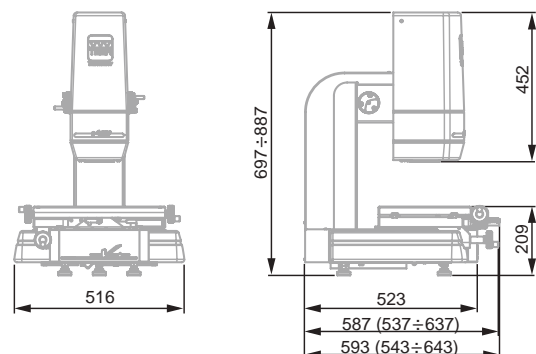

TESA-VISIO 300 GL MANUAL



Key features:

Optical All machines are equipped as standard with a motorized zoom and a color camera.

Lighting

- All machines are equipped with light sources light-emitting diodes (long life. Cold light).
- A lighting diascopic useful for profile pictures and measurement through.
- A light two annular segments (4 x 90 + 8° x 45°) useful for illuminating surface millings, holes, chamfers, rounded edges.
- A useful coaxial light for blind holes and cylindrical parts. Each light is independently adjustable via software.

Swiss Design Each machine consists of a granite structure ensuring rigidity and stability required by any system of measurement precision.

No	=		0±	✳	✳
06830602	TESA-VISIO 300 GL man. 12X zoom	300 x 200 x 150 mm (X/Y/Z)	MPE _{x,y} (Ex, Ey) = (2 + 4L*/1000) MPE _{xy} (Exy) = (2,5 + 4L*/1000) MPE _z (Ez) = (3,9 + 5L*/1000) *L = mm	Manuals	4 x 90° + 8 x 45°
06830601	TESA-VISIO 300M GL man. 6,5 x zoom	300 x 200 x 150 mm (X/Y/Z)	MPE _{x,y} (Ex, Ey) = (2 + 4L*/1000) MPE _{xy} (Exy) = (2,5 + 4L*/1000) MPE _z (Ez) = (3,9 + 5L*/1000) *L = mm	Manuals	4 x 90° + 8 x 45°

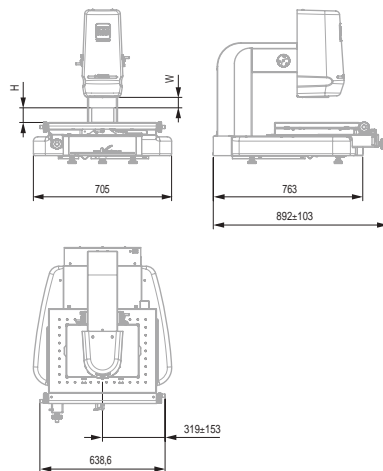

OPTIONAL ACCESSORIES:

06860030	Lens 0,5x
06860031	Lens 0,75x
06860032	Lens 1,5x
06860033	Lens 2x
06860145	Collimated light
06860186	Foot pedal for TESA-VISIO manual
06860187	TESA-REFLEX Vista Compare
06860287	0,5x lens
06860288	0,75x lens
06860289	1,5x lens
06860290	2x lens
06860400	Base kit
06860401	Advanced kit
06869122	PLASTIFORM Full case



MPE_{x,y}* (EX, EY) = (2,0 + 4 L/1000) μm
MPE_{xy}* (EXY) = (2,5 + 4 L/1000) μm
MPE_z* (EZ) = (3,9 + 5 L/1000) μm * L en mm



Systems opto - electronic with incremental scales, resolution 0,05 μm



Rigid granite structure



100 ± 240 VAC
± 10 %; 50 ± 60 Hz



Load capacity 20 kg



10° C to 40° C



80 %, no condensation



Transport Packaging (W x D x H): 1630 x 1140 x 1360 mm



Calibration certificate



Déclaration of conformity



Measurement volume(X/Y/Z): 300 x 200 x 150 mm



Surface table (X/Y): 550 x 430 mm



Shipped assembled



170 kg



Resolution: 0,001 mm



20° C ± 1° C



OPTICAL

Additional lenses for greater magnification range.

Additional Lenses for 6,5 Zoom

Mounts on TESA-VISIO 200 and 300 GL equipped with 6,5x lens.





06860030	Lens 0,5x
06860031	Lens 0,75x
06860032	Lens 1,5x
06860033	Lens 2x

Indicative values for a 20-inch monitor with a 6,5x magnification (0,7x to 4,5x), also with additional lens

	06860030	06860031	-	06860032	06860033
Lenses	0,5x	0,75x	-(1x)	1,5x	2x
Magnifications	15 ÷ 85	22,5 ÷ 127,5	30 ÷ 170	45 ÷ 255	60 ÷ 340
Work distance (W) in mm	175	110	90	50	35
Max. height (H) in mm	0 ÷ 45	0 ÷ 110	0 ÷ 130	0 ÷ 170	0 ÷ 185
Max. field of view in mm	12,8 x 9,6	8,5 x 6,4	6,4 x 4,8	4,2 x 3,2	3,2 x 2,4
Min. field of view in mm	2,2 x 1,6	1,5 x 1,1	1,1 x 0,8	0,7 x 0,5	0,5 x 0,4

Additional Lenses for 12x Zoom

Mounts on TESA-VISIO 300 GL equipped with x12





06860287	0,5x lens
06860288	0,75x lens
06860289	1,5x lens
06860290	2x lens

Indicative values for a 20-inch monitor with a 12x (0,58x to 7x), also with additional lens

	06860287	06860288	-	06860289	06860290
Lenses	0,5x	0,75x	-(1x)	1,5x	2x
Magnifications	13 ÷ 130	19,5 ÷ 181,5	26 ÷ 260	39 ÷ 390	52 ÷ 520
Workd distance (W) in mm	165	105	85	50	30
Max. height (H) in mm	0 ÷ 55	0 ÷ 115	0 ÷ 135	0 ÷ 170	0 ÷ 190
Max. field of view in mm	14,7 x 11	9,8 x 7,3	7,3 x 5,5	4,9 x 3,7	3,6 x 2,7
Min. field of view in mm	1,4 x 1,1	0,9 x 0,7	0,7 x 0,5	0,4 x 0,3	0,3 x 0,2



ILLUMINATION

To make parallel the diascopic light and avoid reflection phenomena when measuring parts cylindriques

Diascopic Parallel Light

	
06860145	Collimated light





CLAMPING KITS

Two kits to choose from for attachment suitable for all room types:

- Basic
- Advanced

Fixing Kit for TESA VISIO

Workholding kits

	
06860400	Base kit
06860401	Advanced kit





ADDITIONAL ACCESSORIES

Ground control for entering points for TESA-VISIO manual

Foot Switch for Data Capture

For manual TESA-VISIO

	
06860186	Foot pedal for TESA-VISIO manual



SOFTWARE FOR VISION SYSTEMS

– TESA-REFLEX Vista for manual TESA-VISIO

TESA-REFLEX Vista Software

For manual vision machines

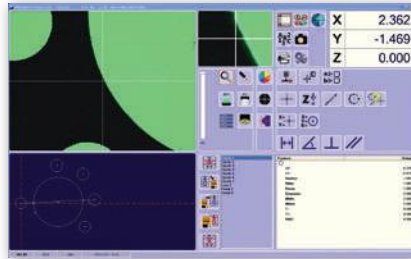

TESA-REFLEX Vista Compare Option

Visual comparison of the component with its CAD model (option within the TESA-REFLEX) software)

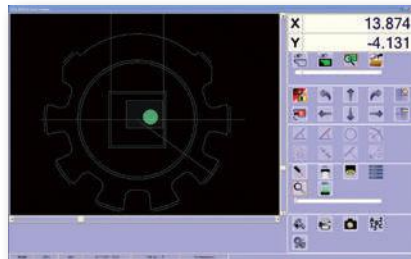

TESA-SCOPE VERTICAL MODEL





















TESA-SCOPE II 300V probes are available with a measurement range of 200 x 100 mm while the "Plus" version has a field measuring 300 x 150 mm.

TESA-SCOPE II 300V and 300V Plus





Perfectly adapted to the control of parts and other planar surface of the micromechanical components .

- Profile projectors vertical light.
 - 360° rotating screen frosted glass . Ø 300 mm. Etched reticles 30°, 60° and 90°, equipped with four fixed - diagrams .
 - Rotate the screen with sexagesimal and decimal display resolution in minutes - Reset ABS / INC .
 - Profile illumination with green filter included . Increases contrast , facilitates measurement and decreases the influence of the operator.
 - Surface illumination with fiber optic adjustable for optimal projection of the image.
 - "Save Lamp" system . Automatic stop lamp when the projector is not used for several minutes (life bulbs 5 times on average).
 - Quick-change goals , bayonet .
 - Coordinate Measuring Table, equipped with an optoelectronic rule, resolution 0,001 mm .
- Measuring range:
- 200 x 100 mm
 - X axis with a clutch for a quick trip.
 - Move the X axis for right and left handed.
 - Maximum load of 10 kg.
- Lateral support for documents.



-  Field measuring 200 x 100 mm (X / Y)
-  Résolution 0,001 mm
-  Measuring system with incremental scales, opto-electronics, resolution 0,001 mm.
-  In a coordinate direction (4,5 + L/40) ≤ 8 µm (L = mm) big table (5 + L/20) µm (L = mm)
-  Optical precision ± 0,05 % in lighting profile, ± 0,10 % in surface lighting.
-  Surface 350 x 210 mm (X/Y)
-  Stable and rigid steel structure Table in anodized aluminum
-  Load capacity 10 kg
Lighting Profile: lamp 24V 150W with thermal
Lighting filter surface: adjustable fiber optic lamp 24V 200W with thermal filter
-  115 ÷ 230 VAC ± 10 %; 50 ÷ 60 Hz
-  20°C ± 1°C
-  10°C to 40°C
-  80 %, without condensation
-  IP40
-  IEC 61010
EN 60204
EN 61326-1
-  110 kg
-  Comes fully assembled, objectives to be ordered separately.
-  Shipping Packaging
-  Serial number
-  Declaration of conformity
-  TESA measuring report



		Base	Measuring Table			Digital Readout / Control Panel		
			X = 200 mm Y = 100 mm	X = 300 mm Y = 150 mm		TS100	TS300	TS300E
								
TESA-SCOPE II 300V	06830041	●	●	-	●	-	-	
TESA-SCOPE II 300V	06830042	●	●	-	-	●	-	
TESA-SCOPE II 300V	06830043	●	●	-	-	-	●	
								
TESA-SCOPE II 300V Plus	06830044	●	-	●	●	-	-	
TESA-SCOPE II 300V Plus	06830045	●	-	●	-	●	-	
TESA-SCOPE II 300V Plus	06830046	●	-	●	-	-	●	

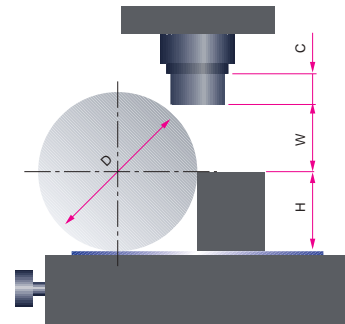
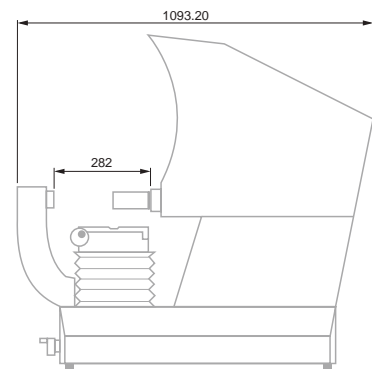
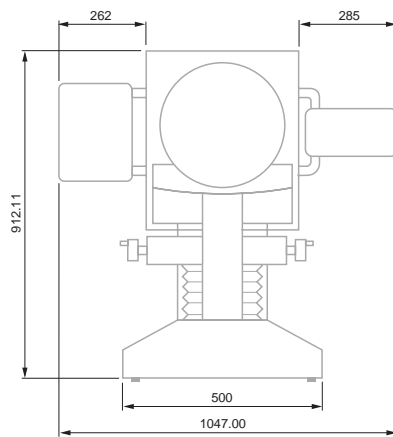

Telecentric Lenses for TESA-SCOPE 300V and 300V Plus

For TESA-SCOPE II 300V and 300V Plus



No	=	✳	✳	✳	✳	✳
		Object-field, mm	Working distance (W), mm	Maximum height (H), mm	Maximum diameter (D), mm	Objective length (C), mm
06860001	Lens 300V - 10x	30	80	83	166	37
06860002	Lens 300V - 20x	15	82	83	166	35
06860003	Lens 300V - 25x	12	70	83	166	47
06860004	Lens 300V - 31, 25x	9,6	56	83	166	61
06860005	Lens 300V - 50x	6	53	83	166	64
06860006	Lens 300V - 100x	3	43	83	166	74

Accessories for TESA-SCOPE Vertical Model

For TESA-SCOPE II 300V and 300V Plus

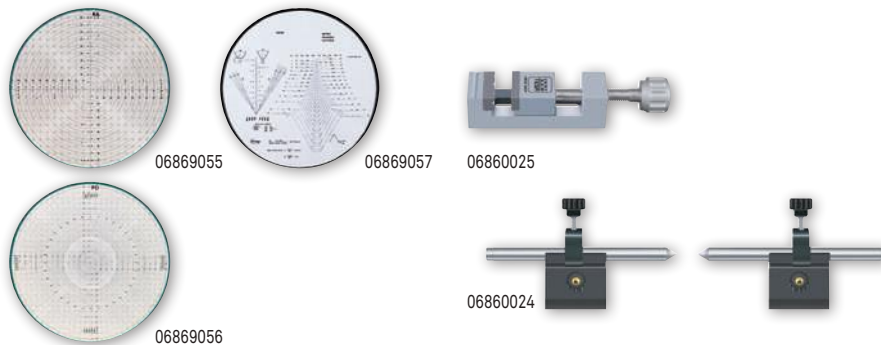

No	=
06860015	Glass window 200 X 100 mm
06860016	Glass window 150 mm x 300 mm
06860017	300 mm diameter viewing screen with 4 overlay chart clips
06860020	Profile lamp, 24 Volts - 150 Watts
06860021	Surface lamp, 24 Volts - 200 Watts
06860060	Ø 90 mm rotary table, for table 200 x 100 mm
06860061	Ø 90 mm rotary table, for table 300 x 150 mm
06860022	Ø 150 mm rotary table, for table 200 x 100 mm
06860029	Ø 150 mm rotary table, for table 300 x 150 mm
06860024	V-blocks and centres
06860025	Vise stage
06860027	TESA practice piece
06869055	Measuring foil, type RA, for radius, circle, bending radius
06869056	Measuring foil, type PO, for radius and angle
06869057	Measuring foil, type M" ISO, for thread measurement
06769007	Set of prism



06860017

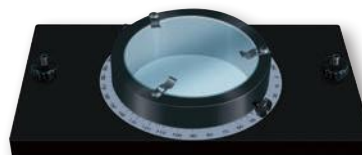

06860060



06860022 / 29



TESA-SCOPE HORIZONTAL MODEL





















TESA-SCOPE II 355H are available with a measurement range of 200 x 100 mm while the "Plus" version has a field measuring 200 x 100mm.

TESA-SCOPE II 355H and 355H Plus





Are ideally suited for control rooms Revolution

- Profile projectors horizontal light.
 - 360° rotating screen frosted glass , Ø 355 mm. Etched reticles 30°, 60° and 90°, equipped with four fixed - diagrams .
 - Rotate the screen with sexagesimal and decimal display resolution in minutes
 - Reset ABS / INC
 - Profile illumination with green filter included . Increases contrast , facilitates measurement and decreases the influence of the operator.
 - Surface illumination with fiber optic adjustable for optimal projection of the image.
 - Save Lamp System. Automatic shutdown of lamps after several minutes of non- use of the projector (life bulbs multiplied by 5 average)
 - Quick-change goals , bayonet .
 - Coordinate Table equipped with opto -electronics rule, resolution 0,001 mm.
- Measuring range:
- 200 x 100 mm.
 - X axis with a clutch system for a quick trip.
 - Moving in the direction of X coordinate for right and left handed .
 - Maximum load of 10 kg , without affecting accuracy.
- Lateral support for documents.



-  Field measuring 200 x 100 mm (X / Y)
-  Resolution 0,001 mm
-  Measuring system with incremental scales, opto-electronics, resolution 0,001 mm.
-  In a coordinate direction (4,5 + L/40) µm ≤ 8 (L in mm) µm large table (5 + L/20) µm (L in mm)
-  Optical precision ± 0.05 % lighting profile, ± 0.10 % in surface lighting.
-  Surface table 350 x 100 mm (X / Y)
-  Stable and rigid steel structure Table in anodized aluminum
-  Capacity Load 10 kg Lighting Profile: Lamp 24 V, 150 W with thermal filter. Surface lighting: directional fiber optic lamp 24 V, 200 Watts with thermal filter.
-  Course focus 80 mm
-  115 ÷ 230 VAC ± 10 %, 50 ÷ 60 Hz
-  20°C ± 1°C
-  10°C to 40°C
-  80 % without condensing
-  IP40
-  CEI 61010 EN 60204 EN 61326-1
-  110 kg
-  Comes fully assembled, objectives to be ordered separately
-  Shipping packaging
-  Serial Number
-  Declaration of conformity
-  TESA Report



		Base	Measuring table			Digital Readout / Control Panel		
			X = 200 mm Y = 100 mm	X = 300 mm Y = 100 mm		TS 100	TS 300	TS 300 E
								
TESA-SCOPE II 355H	06830051	●	●	-	●	-	-	
TESA-SCOPE II 355H	06830052	●	●	-	-	●	-	
TESA-SCOPE II 355H	06830053	●	●	-	-	-	●	
								
TESA-SCOPE II 355H Plus	06830054	●	-	●	●	-	-	
TESA-SCOPE II 355H Plus	06830055	●	-	●	-	●	-	
TESA-SCOPE II 355H Plus	06830056	●	-	●	-	-	●	

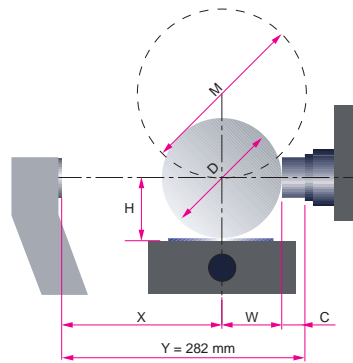
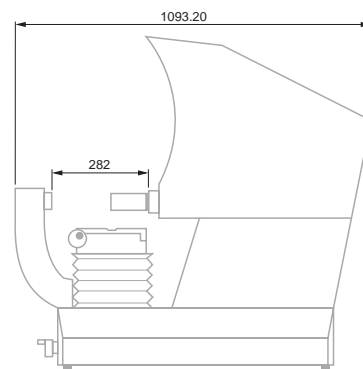
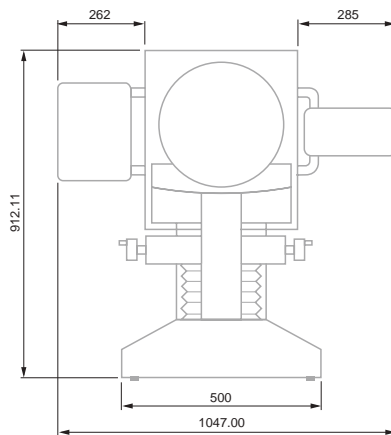

Telecentric Lenses for TESA-SCOPE 355H and 355H Plus

For TESA-SCOPE II 355H and 355H



No	=	✳	✳	✳	✳	✳	⏏
		Objecti-field mm	Working distance (W) mm	Max. Height (H) mm	Max. diameter (D) mm	Objective length (C) mm	Max. width of component X = Y - (W+C)
06860001	Lens 355H - 10x	35	80	100	200	37	165
06860002	Lens 355V - 20x	17,5	82	100	200	35	165
06860003	Lens 355H - 25x	14	70	100	200	47	165
06860004	Lens 355H - 31,5x	11.2	56	100	200	61	165
06860005	Lens 355H - 50x	7	53	100	200	64	165
06860006	Lens 355H - 100x	3.5	43	100	200	74	165

Accessories for TESA-SCOPE Horizontal Model

For TESA-SCOPE II 355H and 355H Plus

No	=
06860018	355 mm dia. viewing screen with 4 overlay chart clips
06860020	Profile lamp, 24 Volts – 150 Watts
06860021	Surface lamp, 24 Volts – 200 Watts
06860056	Rotary table for model 355H
06860024	V-blocks and centres
06860025	Vise stage
06860026	Vise stage with base
06860058	Vise for rotary table N° 06860056
06860057	Prise for rotary table N° 06860056
06769007	Set of prism



06860057



06860024



06860058



06860025



06860026



06860056

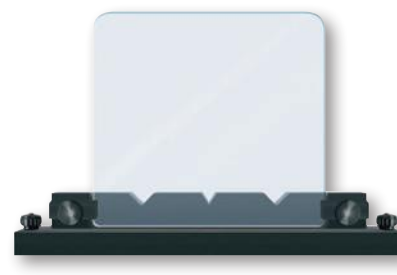

06860059



CONTROL PANELS

3 panels are available with TESA-SCOPE:

- Box TS100
- Control panel TS300 with 2D software TESA REFLEX
- Control panel TS300E with 2D TESA REFLEX software and edge detector

TS100 Digital Readout

- Numerical display (X/Y axes)
- Resolution to 0,001 mm
- Inch/metric conversion
- Separate zeroing of display in both X/Y-axes
- ABS/INC measuring mode
- Linear correction of scaling errors (X/Y-axes)
- Control option for both profile and surface illumination
- RS232 digital output (SPC Printer)

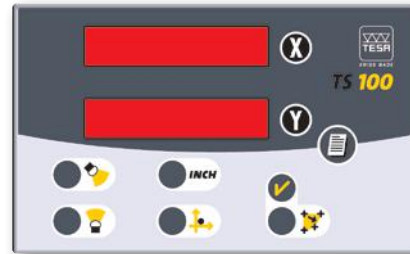

Measuring functions

- Diameter 3 to 10 data points
- Radius 3 to 10 data points
- Centre Centre-to-centre distance of the last distance measured feature (radius or diameter)
- Auto Enter Automatic value acquisition

TS300 or TS300E Control Panel

Each unit is able to run TESA-REFLEX 2D – The Reference in terms of simplicity and reliability.

Geometric form elements

- Point
- Line
- Circle

Measuring functions

- Alignment
- Input of reference values
- Translation – Rotation

Construction features

- Intersection
- Bolt hole circle
- Line

Result output

- Data transfer through the RS232 output
- Possible conversion into DXF format
- Statistical data processing etc.



Shipping packaging



RS232



Model 300V: integrated into the unit.
Models 355H : single unit



Icon-based User's guidance



Shipping packaging



89 x 118 mm display field with illuminated background



RS232



7-decade digit display plus sign for all measured values.





Shrinking: less than 1 µm/mm after removal of the mould. Stability: physical properties allow to produce prints which do not deteriorate with time. They will neither be affected by surroundings – hence usable as master standards.



Components with additives free from chlorine, fluorine or sulfur. Being non-toxic and on-polluting can be used with no special restriction



Temperature 20°C



< 10°C: no more polymerization

PLASTIFORM

PLASTIFORM moulding pastes allow print molding of complex internal machined parts, which can then be viewed and checked using optical, non-contact measuring equipment. PLASTIFORM mixing pastes» consist of two components, which have to be mixed in equal proportion to ensure proper polymerization. The test object to be reproduced by print molding must be perfectly clean and grease-free before applying Plastiform.

BAD

Fluid consistency best suited for moulding internal and full prints of small and medium sizes. Medium elasticity (10 % of the core) allows prints to be removed in most cases. Reproduces the finest details and can be used for indirect inspection of the surface finish by sight comparison with use of master roughness specimens. Easily cut with the special cutter.

DAV

DAV of fluid consistency best suited for moulding internal and full prints of small and medium sizes. High elasticity (20 % of the core) allows hard prints to be removed such as large re-entrant angle, groove, complex internal shape. Reproduces fine details. Difficult to cut with the special cutter. Print will be preferably checked as a whole.

RGX80

RGX80 is the hardest product of the cartridge range. Pasty consistency best suited for moulding whole internal prints having varying sizes. Weak stretching property and elasticity make it appropriate for easily removable moulding prints.

LKAD

Malleable consistency best suited for moulding internal, external and sectorial prints of small and medium sizes. Applied by hand. Low elasticity (from 1 to 2% of the core) makes it convenient for moulding prints that are removed with ease. Also appropriate for prints held mechanically if desired. Easily cut with the cutter.

PLASTIFORM Set

PLASTIFORM full case Consisting of:

- 1 DS50 injection handle
- 1 Cutter, special with two parallel blades
- 1 PLASTIN (200 g)
- 50 Mixer-Injectors
- 10 Injector end pieces
- 1 DN1 spot remover, 400 ml 21 Rings for mould removal
- 3 PLASTIFORM BAD 50 ml
- 3 PLASTIFORM DAV 50 ml
- 2 PLASTIFORM RGX80 50 ml



Properties

	BAD	DAV	RGX80	LKAD
Consistency (max 15)	Fluid (2)	Fluid (4,5)	Pasty	Malleable
Hardness (shore A)	50	20	80	70
Cut using the dual-blade cutter	Easy	Uneasy	Easy	Easy
Check	●	–	●	●
– With contact	●	–	●	●
– Without contact	●	●	●	●
– Roughness	–	–	●	–
Elasticity	Flexible	Highly flexible	Rigid	Rigid



06869122



PLASTIFORM Full case



Accessories for PLASTIFORM

- BAD, DAV, RGX80, LKAD Cartridges
- Plastin
- Tests kits
- Mixers-injectors
- Cutter, special with two parallel blades
- Injector nozzles DS50
- DN1 spot remover, aerosol can, 400 ml



No	=
06869101	PLASTIFORM BAD 8 x 50 ml
06869106	Mixing injectors, box of 50 pcs
06869107	Mixing injectors, box of 100 pcs
06869108	Mixing injectors, box of 200 pcs
06869109	Fine nozzles box of 20 pcs
06869110	Plastincine, 200 gr
06869111	Special cutter with two parallel blades
06869112	Plastiform pistol DS50
06869113	Degreasing DN1, aerosol 400 ml
06869102	PLASTIFORM DAV 8 X 50 ml
06869119	PLASTIFORM Lite KIT BAD
06869120	PLASTIFORM Lite KIT DAV
06869118	PLASTIFORM RGX8 50 ml
06869121	PLASTIFORM LK-AD



Coordinate Measuring Machines



THE WAY TO ACCESS 3D MEASUREMENT

Conceived to provide operators with absolute ease of use, the TESA MICRO-HITE 3D steps in to fill the gap between the traditional gauge and the sophisticated CMM. This measuring machine with remarkable capabilities is best used in industrial applications where dimensional conformity of components either produced as single parts or in small to medium batches requires due approval.

Featuring a modern, yet proven design, the machine is built using high quality materials and components, thus ensuring its long-term reliability. The TESA-REFLEX software is intuitive and easy to learn taking only a few hours to master.



MH3D Dual



MH3D 454



MH3D 474





TWO TESA-REFLEX SOFTWARE VERSIONS

The TESA-REFLEX software is the reference for user-friendliness and reliability. Easy and quick to learn and to run, it lets users choose between a large number of options:

- Several modes: measuring, scanning, pass-through.
- Summon and save part programmes.
- Qualification of several probe positions.
- Different ways to save the measurement results: USB stick, RS232 digital output or printer.
- Automated operation

THREE MANUALLY OPERATED PROBE HEADS

All TESA CMM's can accept 3 different manual probe heads to offer the solution that meets each user's need. Each probe head is available from a full range of touch-trigger probes besides high precision SWISS MADE accessories fitting any type of hand-operated measuring machines.

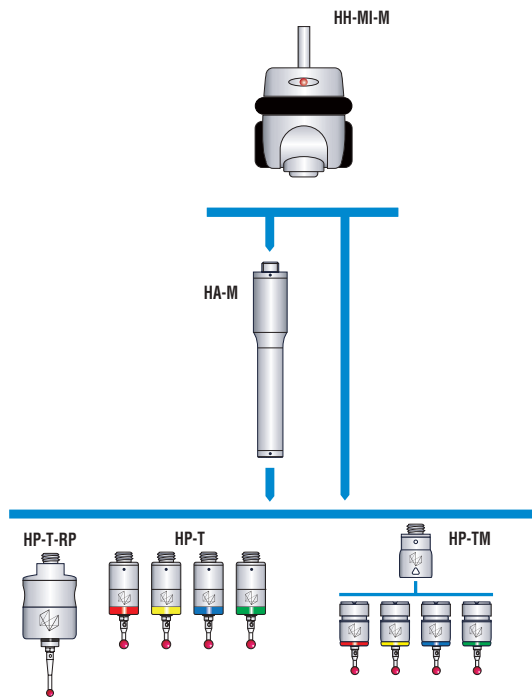



MICRO-HITE 3D Manual

Supplied with TESA-REFLEX software, the MICRO-HITE 3D can turn into a reliable and hard wearing all round shop floor machine easily integrated into the skill set of the operator. Multifunctional, yet easy to use, it is the metrological ace up the inspector's sleeve, replacing a wide range of conventional measuring tools.

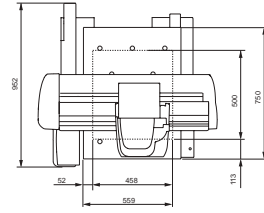
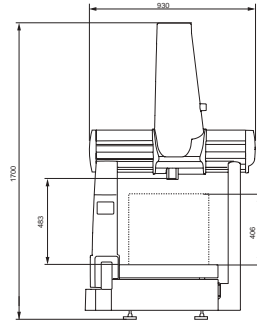

MH3D 454

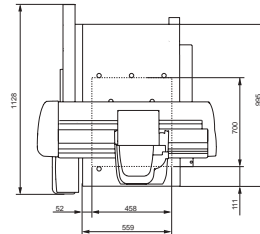
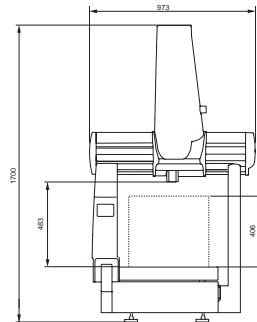

MH3D 474

- EN ISO 10360-2
- 0,001 mm or 0.00001 in
- Opto-electronic measuring systems based on incremental glass scales
- 760 mm/s
- Light alloy machine base, measuring table in granite
- 115 to 230 VAC ± 10 %, 50 to 60 Hz. Absorption 0,3 to 0,7 A
- Air pressure: 3,9 bars (60 to 120 psi). Air absorption: 60 NI/min.
- 13°C to 35°C
-
- Shipping box (W x D x H) : 1100 x 1150 x 2200 mm (for machine version 454) 1580 x 1400 x 2200 mm (for machine version 474)
- Inspection report
- 154 x 116 mm display field with illuminated background
- Measuring volume (X/Y/Z): 460 x 510 x 420 mm (machine version 454) 460 x 710 x 420 mm (machine version 474)
- Maximum dimensions for measured parts: (W x D x H) : 600 x 750 x 430 mm (for machine version 454) 600 x 990 x 430 mm (for machine version 474)
- CMM with moving bridge. Measuring systems along with air bearing guiding in the three coordinate axes.
- Net weight: Versions (454/474) = 210/315 kg (granite tables included). Tables alone : 99/120 kg. Gross weight : 300/445 kg. Maximum weight for measured parts: Version 454 : 227 kg Version 474 : 200 kg
- 20° ± 1°
- MPEE* = (3 + 4 L/1000) µm MPEP = 3 µm * L in mm
- 0,039 µm (system)
- Manual

No	=							
		Displacement	mm	Fine adjust device	Software	Measuring head	Maintenance agreement	Warranty
03939040	MH3D 454 (HH-T)	manual	454	No	TESA-REFLEX MH3D	HH-T	On request	1 year
03939041	MH3D 454 (HH-M)	manual	454	No	TESA-REFLEX MH3D	HH-MI	On request	1 year
03939042	MH3D-F 454 (HH-T)	manual	454	Yes	TESA-REFLEX MH3D	HH-T	On request	1 year
03939043	MH3D-F 454 (HH-MI)	manual	454	Yes	TESA-REFLEX MH3D	HH-MI	On request	1 year
03939240	MH3D 474 (HH-T)	manual	474	No	TESA-REFLEX MH3D	HH-T	On request	1 year
03939241	MH3D 474 (HH-M)	manual	474	No	TESA-REFLEX MH3D	HH-MI	On request	1 year
03939242	MH3D-F 474 (HH-T)	manual	474	Yes	TESA-REFLEX MH3D	HH-T	On request	1 year
03939243	MH3D-F 474 (HH-MI)	manual	474	Yes	TESA-REFLEX MH3D	HH-MI	On request	1 year

It is also possible to order a CMM including a HH-MI-M probe head.



MICRO-HITE 3D DUAL

The software is very well suited to the MICRO-HITE 3D DUAL, making it a versatile machine that can be used by everyone, whether in a laboratory or in a workshop. As it can be used in 2 modes this increases productivity and the machine can be used for a longer period of time in the manufacturing chain.

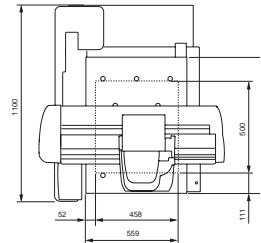
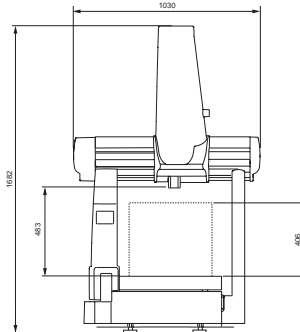

MH3D Dual 454

- EN ISO 10360-2
- 0,001 mm or 0.00001 in
- Opto-electronic systems and incremental glass scales
- Manual mode: 760 mm/s Motorised mode: 200 mm/s
- Light alloy machine base; granite measuring table.
- 115 to 230 VAC ± 10 %, 50 to 60 Hz. Absorption: 0,3 to 0,7 A
- Air pressure: 3,9 bars (70 to 10 psi). Air absorption: 60NI/min.
- 13°C to 35°C
-
- shipping box (WxDxH): 1350 x 1350 x 2200 mm
- inspection report
- 154 X 116 mm display field with illuminated background
- Measuring volume (X/Y/Z): 440 x 490 x 390 mm
- Maximum size of the measured part (W/D/H): 600 x 750 x 430mm
- CMM with moving bridge. Measuring systems along with air bearing guiding in the three axes
- Net weight 225 kg (granite table included). Table alone: 99 kg. Gross weight: 350 kg. Maximum weight for the measured part: 227 kg.
- 20°C ± 1°C
- Manual mode: MPEE* = (3 + 4 L/1000) µm
MPEP = 3 µm
Motorised mode: MPEE* = (2,5 + 3,9 L/1000) µm
MPEP = 2 µm
* L in mm
- 0,039 µm (system)
- Manual probing movements. Manual or motorised execution of a part program.

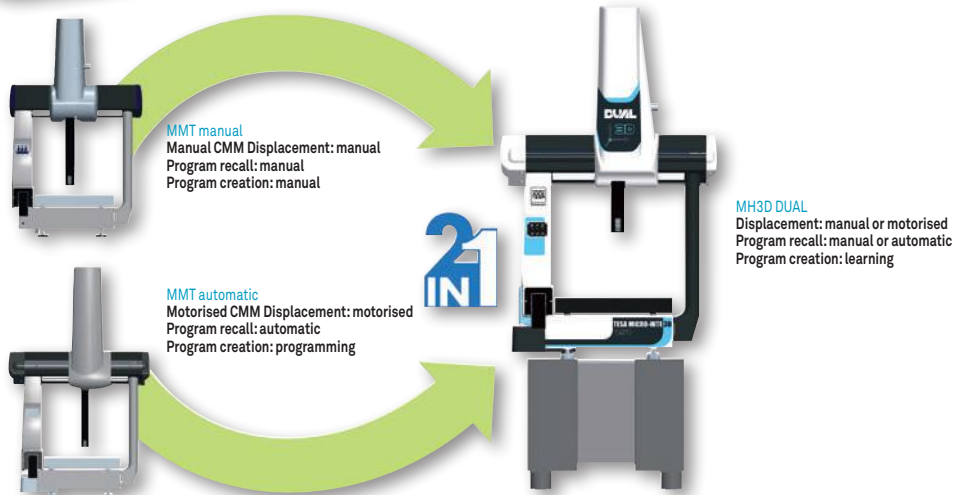

No	Icon	Displacement	mm	Software	Maintenance agreement	Warranty
03939267		manual, motorised, automatic	454	TESA-REFLEX Dual	HH-T	On request 1 year
03939268		manual, motorised, automatic	454	TESA-REFLEX Dual	HH-MI-M	On request 1 year
03939269		manual, motorised, automatic	454	TESA-REFLEX Dual	HH-MI	On request 1 year



HH-T Head

The HH-T is a compact manual probe head with adjustable triggering force.

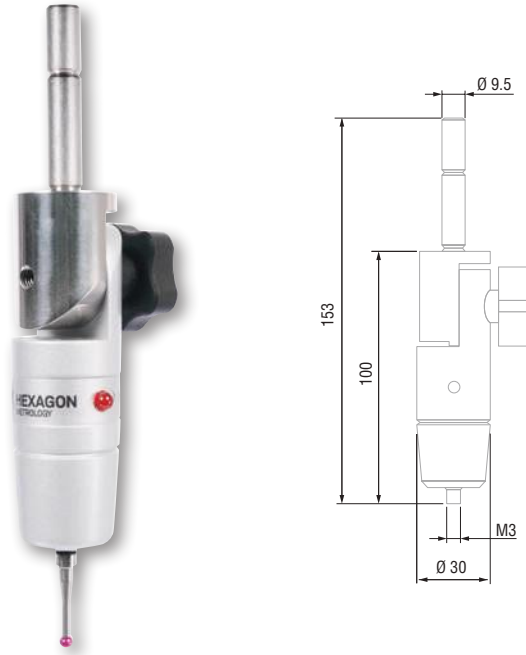

- EN ISO 10360-1
- Directions:
± X, ± Y, +Z
Free stylus travel:
X/Y ±20°, Z + 6 mm
- 30°C to 60°C
- 10°C to 40°C
- Shipping box
- Inspection report with a declaration of conformity
- M3
- Manual

03939020	Head HH-T	Unidirectional, μm $\leq 0,75$	N 0,1 ÷ 0,3	M3	Manual





N EN ISO 10360-1

Directions: ± X, ± Y, +Z
Free stylus travel: X/Y ± 20°, Z + 6 mm

-30°C to 60°C

10°C to 40°C

Shipping box

Inspection report with a declaration of conformity

Each axis can be locked by means of 2 push-buttons

M3

Indexation in increment of 15°

Indexation on 168 positions. Probe orientation: A = 0° to 90° B = ± 180°

Manual

HH-MI Head

The HH-MI is a high-precision indexable probe head integrating a built-in sensor with adjustable triggering force.

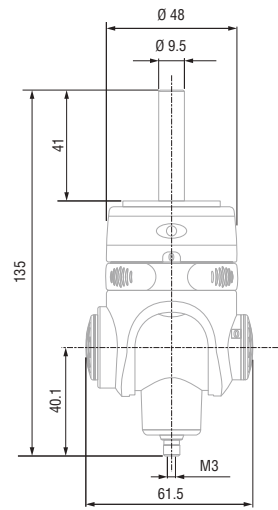

03939030	HH-MI Head	15°	168	Unidirectional, μm $\leq 0,75$	N 0,1 ÷ 0,3	M3	Manual



N EN ISO 10360-1

Each axis can be locked by means of 2 push-buttons

-30°C to 60°C

10°C to 40°C

Shipping box

Inspection report with a declaration of conformity

M8

Indexation by increment of 15°

Indexation on 168 positions. Probe orientation: A = 0° to 90° B = ± 180°

Manual

HH-MI-M Head

The HH-MI-M is a high-precision, indexable manual probe head which can be fitted with any type of accessories featuring a M8 coupling thread.

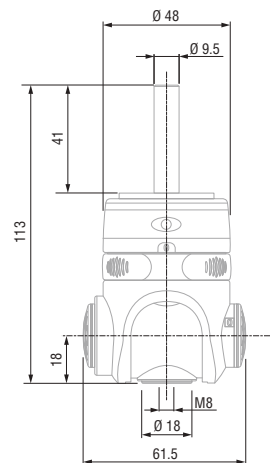

03939031	HH-MI-M Head	15°	168	-	N -	M8	Manual



HP-T Probe

Consist of a small-size module with integrated probe and touch force triggered in 5 directions. M8 thread for coupling any existing probe head, whether manually operated or motor driven. Four models available with a trigger force varying from 0,05 up to 0,10 N.

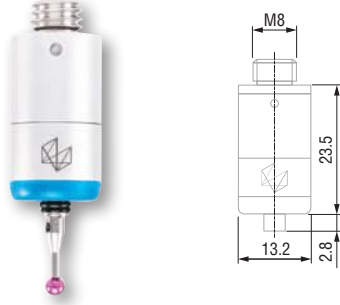

No	=				
		μm	N	Colour	
03939070	HP-T-LF	0,35	0,055 (L = 10 mm)	Red	LF = Low Force
03939071	HP-T-SF	0,35	0,08 (L = 10 mm)	Yellow	SF = Standard Force
03939072	HP-T-MF	0,5	0,10 (L = 25 mm)	Green	MF = Medium Force
03939073	HP-T-EF	0,65	0,10 (L = 50 mm)	Blue	EF = Extended Force

HP-T Probe Kit

Kit including several HP-T probes, allowing to face any application case with different triggering forces.

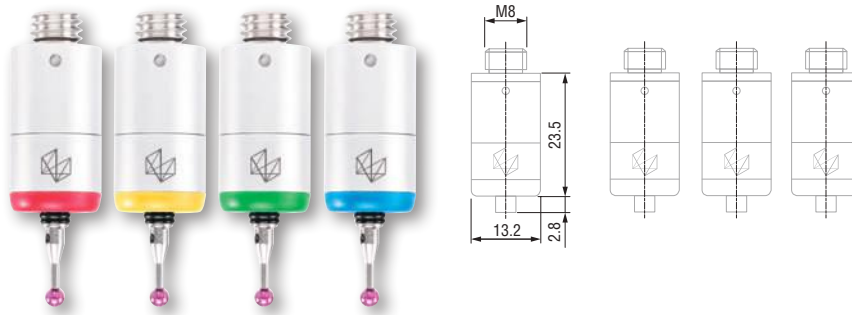

No	=		
03939074	HP-T probe kit	Standard probe	1 x LF + 1 x MF + 1 x SF + 1 x EF

- 600 μA (external supply)
- 5 directions $\pm X, \pm Y, +Z$ Free stylus travel: $X/Y \pm 14^\circ$, $Z + 4 \text{ mm}$
- -10°C to 70°C
- 10°C to 40°C
- IP50
- Shipping box
- Inspection report with a declaration of conformity
- M2
- 9,5 g



- 600 µA (external supply)
- 5 directions ± X, ± Y, +Z Stylus tilting through X/Y ±14°, Z + 4 mm
- 30°C to 60°C
- 10°C to 40°C
- IP30
- Shipping packaging
- Inspection report with a declaration of conformity
- M2
- Triggering force: 10N
- 13,6 g (probe body) 11 g (stylus)

HP-TM Probe

The HP-TM is a small system incorporating a magnetic and isostatic attachment between its body, fixed part of the attachment, and its module, interchangeable part, equipped with a measuring force triggered by contact in 5 directions. Four models with a varying triggering force between 0,05 N and 0,10 N are available. The body is equipped with a M8 thread for mounting on most existing motorized or manual measuring heads.

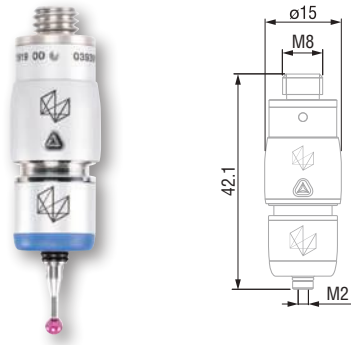

No	=				
		µm	N	Couleur	
03939170	HP-TM-LF	0,35	0,055 (L = 10 mm)	Red	LF = Low Force
03939171	HP-TM-SF	0,35	0,08 (L = 10 mm)	Yellow	SF = Standard Force
03939172	HP-TM-MF	0,5	0,10 (L = 25 mm)	Green	MF = Medium Force
03939173	HP-TM-EF	0,65	0,10 (L = 50 mm)	Blue	EF = Extended Force
03939174	HP-TM probe body	-	-	-	-

HP-TM Probe Kit

Probe kit including a HP-TM probe body and several modules, allowing fast, easy and safe changes in the system, without any negative impact on the measuring results.

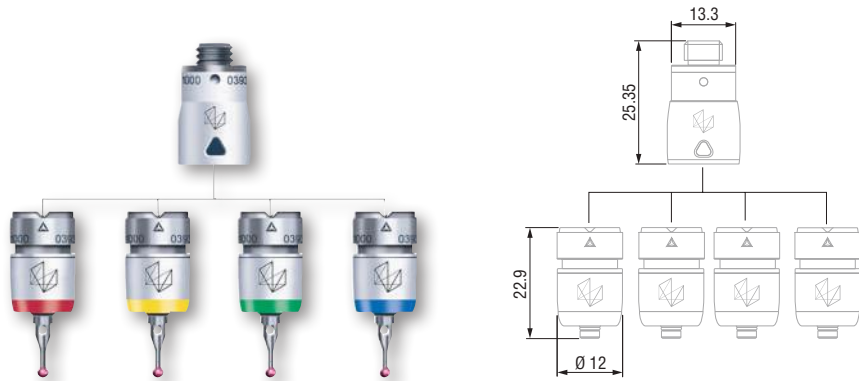

No	=		
03939175	Probe kit HP-TM N°1	Magnetic probe	1x LF + 1x MF + 1x SF + 1x EF + body
03939210	Probe kit HP-TM N°2	Magnetic probe	2x SF + body
03939211	Probe kit HP-TM N°3	Magnetic probe	1x SF + 1x MF + body
03939212	Probe kit HP-TM N°4	Magnetic probe	1x SF + 1x EF + body
03939213	Probe kit HP-TM N°5	Magnetic probe	2x MF
03939214	Probe kit HP-TM N°6	Magnetic probe	1x EF + 1x MF + body
03939215	Probe kit HP-TM N°7	Magnetic probe	2x EF + body
03939216	Probe kit HP-TM N°8	Magnetic probe	1x LF + body
03939217	Probe kit HP-TM N°9	Magnetic probe	1x SF
03939218	Probe kit HP-TM N°10	Magnetic probe	1x MF + body
03939219	Probe kit HP-TM N°11	Magnetic probe	1x EF + body



HP-T-RP Probe

HP-T-RP is a complete, robust and precise touch trigger probe, which can be used on any manual or motorised CMM as well as in any manufacturing environment, even the most hostile. Adjustable triggering force for optimum efficiency according to chosen configuration for the stylus. This force also allows for the use of styli whose weight and length are above normal.

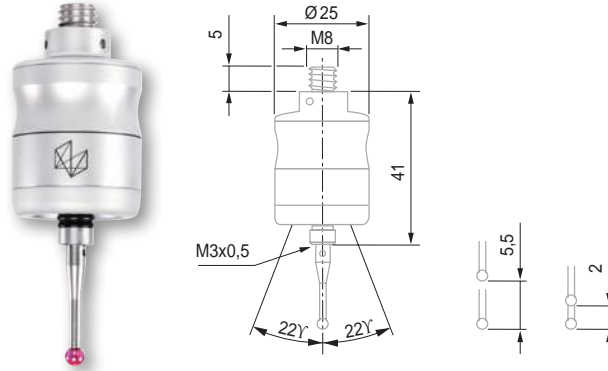

- 600 µA (external supply)
- 5 directions ± X, ± Y, +Z Free stylus travel: X/Y ±22°, Z + 5,5 mm
- 10°C to 70°C
- 10°C to 40°C
- IP50
- Shipping box
- Inspection report with a declaration of conformity
- M3
- 43 g

No	HP-T-RP	Unidirectional, µm	N	Robust probe	Length of stylus, mm	RP = Robust Probe
03939350	HP-T-RP	≤ 0,35	0,1 ÷ 0,3	Robust probe	≤ 100	RP = Robust Probe





Ruby Ball Stylus, M2 Thread

These styli are used for the majority of probing applications. Highly robust, thanks to their manufacture from industrial rubies, they are however very sensitive, thus avoiding any capture of unwanted points during the movements of a 3D machine.

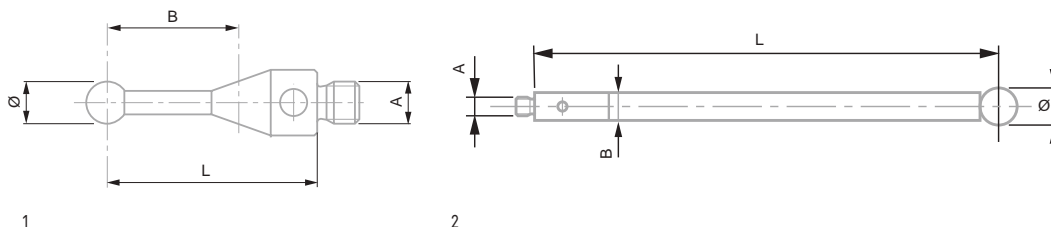





No	Rod	Drawing N°	A mm	Ø mm	L mm	B mm	g
03969201	Inox	1	M2	1	10	4,5	0,3
03969202	Inox	1	M2	2	10	6	0,3
03969203	Inox	1	M2	3	10	7,5	0,4
03969204	Inox	1	M2	4	10	10	0,5
03969205	Inox	1	M2	5	10	10	0,7
03969206	Inox	1	M2	6	10	10	1
03969208	Inox	1	M2	8	11	11	1,5
03969212	Inox	1	M2	2	20	14	0,5
03969213	Inox	1	M2	3	20	17	0,5
03969214	Inox	1	M2	4	20	20,2	0,8
03969220	Tungsten carbide	1	M2	0,5	10	3	0,3
03969221	Tungsten carbide	1	M2	1	20	7	0,6
03969222	Tungsten carbide	1	M2	2	20	15	0,45
03969223	Ceramic	1	M2	3	50	42,5	0,83
03969224	Ceramic	1	M2	4	50	42,5	0,91
03969225	Inox	1	M2	2,5	10	6	0,3
03969226	Tungsten carbide	1	M2	2,5	20	14	0,4
03969259	Tungsten carbide	1	M2	1	27	20,5	0,4
03969260	Carbon	2	M2	4	50	3	1
03969261	Tungsten carbide	1	M2	1,5	30	25	0,58
03969262	Tungsten carbide	1	M2	2	30	25	0,99
03969263	Tungsten carbide	1	M2	3	30	25	1,49
03969267	Tungsten carbide	1	M2	0,7	10	4	0,3
03969268	Tungsten carbide	1	M2	0,3	10	2	0,3
03969269	Tungsten carbide	1	M2	0,5	20	7	0,48
03969271	Tungsten carbide	1	M2	1	20	12,5	0,41
03969272	Tungsten carbide	1	M2	1,5	20	12,5	0,5
03969276	Carbon	2	M2	6	50	50	1,2
03969282	Tungsten carbide	1	M2	2	40	35	1,29
03969283	Tungsten carbide	1	M2	3	40	35	1,97
03969284	Tungsten carbide	1	M2	3	40	35	2,04
03969286	Carbon	2	M2	6	30	30	0,96
03969293	Carbide	1	M2	3	50	42,5	2,44
03969294	Carbide	1	M2	4	50	42,5	2,52
03969295	Tungsten carbide	1	M2	5	50	42,5	3,75

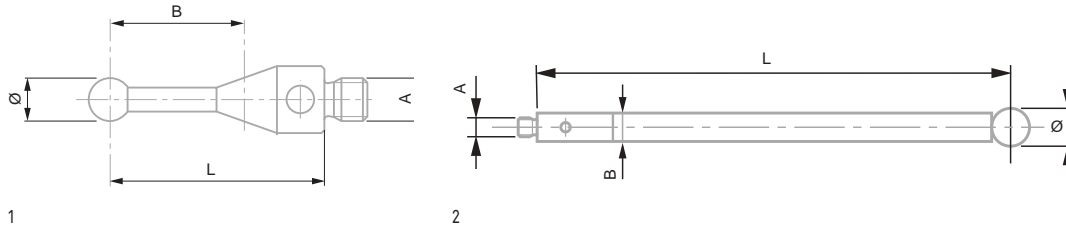

Ruby Ball Stylus, M3 Thread

These styli are used for the majority of probing applications. Highly robust, thanks to their manufacture from industrial rubies, they are however very sensitive, thus avoiding any capture of unwanted points during the movements of a 3D machine.



No							
	Rod	Drawing N°	A mm	Ø mm	L mm	B mm	g
03969301	Inox	1	M3	1	21	4	1,1
03969302	Inox	1	M3	2	21	8	1,1
03969303	Inox	1	M3	3	21	12	1,1
03969304	Inox	1	M3	4	21	17	1,4
03969305	Inox	1	M3	5	21	21	1,55
03969310	Tungsten carbide	1	M3	0,5	21	3	1,1
03969312	Tungsten carbide	1	M3	2	21	15	0,8
03969324	Inox	-	M3	3	10	-	-
03969326	Inox	-	M3	6	10	-	-
03969332	Tungsten carbide	1	M3	2,5	21	12,5	1,3
03969343	Tungsten carbide	1	M3	3	40	32,5	2,3
03969353	Tungsten carbide	1	M3	3	50	42,5	2,78





Hemispherical Styli, M2 Thread

Styli usually made of ceramic are generally used to measure deep bores or to avoid taking into account the unwanted irregularities when measuring.

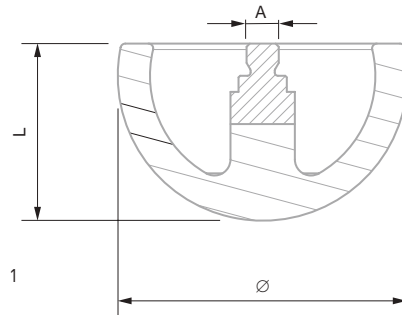

No	=	Rod	Drawing N°	A mm	Ø mm	L mm	B mm	g
03969218	Hemispherical stylus, Ø 18 mm	Ceramic	1	M2	18	11	-	3,3



Hemispherical Styli, M3 Thread

Styli usually made of ceramic are generally used to measure deep bores or to avoid taking into account the unwanted irregularities when measuring.

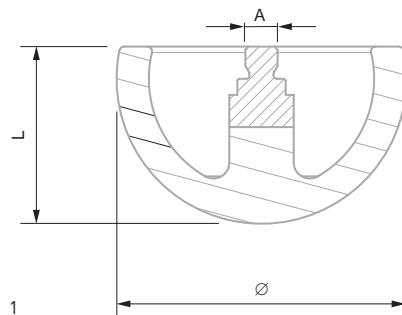

No	=	Rod	Drawing N°	A mm	Ø mm	L mm	B mm	g
03969330	Hemispherical stylus, Ø 30 mm	Ceramic	1	M3	30	17	-	13



Star Styli, M2 Thread

These styli are supplied with several ruby ball tips fixed in different directions. This feature allows a much faster measurement when inspecting internal features without time being wasted by changing the position of a probe.

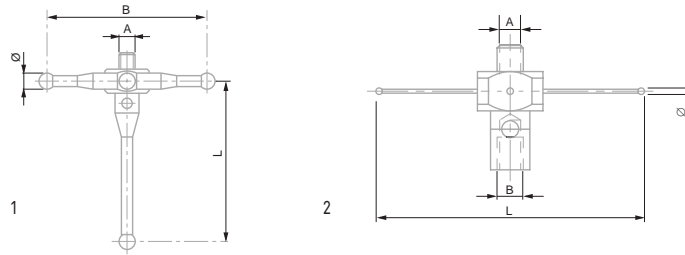

No	=		Rod		Drawing N°	A mm	Ø mm	L mm	B mm	g
03969055			Inox	1	M2	2	20	20	1,5	
03969056			Inox	1	M2	2	20	30	1,8	
03969081			Inox	1	M2	2	18	20	1,3	
03969082			Inox	1	M2	2	18	30	1,7	
03969210			Inox	2	M2	0,5	20	M2	0,7	

Star Styli, M3 Thread

These styli are supplied with several ruby ball tips fixed in different directions. This feature allows a much faster measurement when inspecting internal features without time being wasted by changing the position of a probe.

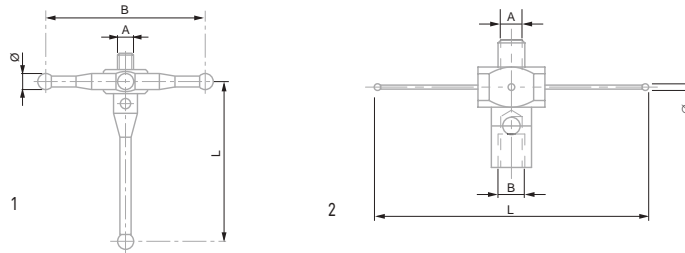

No	=		Rod		Drawing N°	A mm	Ø mm	L mm	B mm	g
03969057			Inox	1	M2	2	20	20	2,2	
03969058			Inox	1	M2	2	20	30	2,5	
03969083			Inox	1	M2	2	18	20	2,2	
03969084			Inox	1	M2	2	18	30	2,5	

Cylindrical Styli, M2 Thread

These styli are principally used for the measurement of threads.

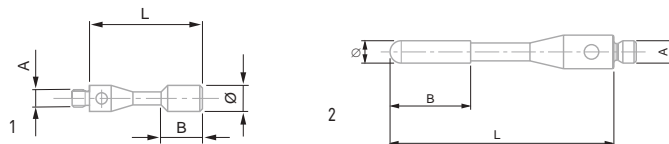

No			Rod		Drawing N°	A mm	Ø mm	L mm	B mm	g
03969251			Inox	1	M2	1,5	11	1,5	0,3	
03969252			Inox	1	M2	3	13	3,8	0,6	
03969253			Inox	1	M2	3	13	4	0,5	
03969292			Tungsten carbide	2	M2	2	20	7,2	0,5	





Parallel Styli, M2 Thread

These styli are principally used for the measurement of threads.

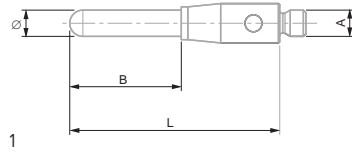

No	Rod	Drawing N°	A mm	Ø mm	L mm	B mm	g
03969277	Carbide	1	M2	0,5	15,3	7,8	0,3
03969278	Carbide	1	M2	1	35,5	29,8	0,7
03969279	Carbide	1	M2	2	16	8,5	0,8
03969280	Carbide	1	M2	2	40	32	2
03969281	Carbide	1	M2	3	22,5	-	2



Extension M2

The extension allows to enlarge the distance between the probe and the tip of the stylus in order to avoid collision in the depth measurement (e.g. bore).

The use of extensions can greatly reduce the accuracy of the measuring system.

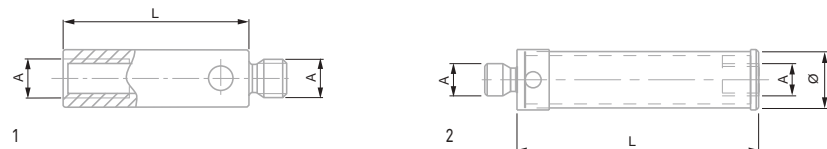

No	Extension	Rod	Drawing N°	A mm	Ø mm	L mm	B mm	g
03969230	Extension, L5 mm	Inox	1	M2	3	5	-	-
03969231	Extension, L10 mm	Inox	1	M2	-	10	-	0,5
03969232	Extension, L20 mm	Inox	1	M2	-	20	-	1
03969233	Extension, L30 mm	Inox	1	M2	-	30	-	1,6
03969234	Extension, L40 mm	Inox	1	M2	3	40	-	1,8
03969238	Extension, L50 mm	Carbon	1	M2	3	50	-	1
03969239	Extension, L70 mm	Carbon	1	M2	3	70	-	1,3
03969240	Extension, L90 mm	Carbon	1	M2	3	90	-	1,5
03969246	Extension, L40 mm	Ceramic	1	M2	3	40	-	1,22
03969247	Extension, L50 mm	Ceramic	1	M2	3	50	-	1,51
03969270	Extension, L40 mm	Carbon	1	M2	3	40	-	0,9



Extension M3

The extension allows to enlarge the distance between the probe and the tip of the stylus in order to avoid collision in the depth measurement (e.g. bore).

The use of extensions can greatly reduce the accuracy of the measuring system.

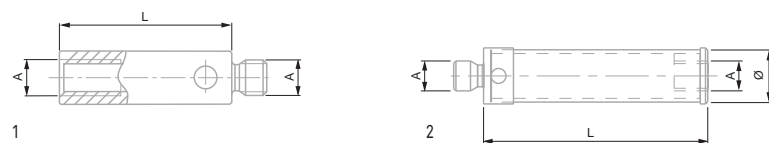

No	Extension	Rod	Drawing N°	A mm	Ø mm	L mm	B mm	g
03969044	Extension, L10 mm	Inox	1	M3	-	10	-	0,8
03969045	Extension, L20 mm	Inox	1	M3	-	20	-	1,8
03969320	Extension, L35 mm	Inox	1	M3	-	35	-	2,9



Cross-pieces, M2

Base on which one or several identical or different kind of styli can be mounted. It can be converted into a star stylus or any other desirable configuration.

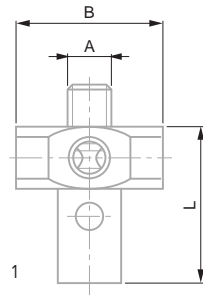

No	=	Rod	Drawing N°	A mm	Ø mm	L mm	B mm	g
03969054	5 way cross shaped stylus M2	Inox	1	M2	-	7,5	7	1,1

Cross-pieces, M3

Base on which one or several identical or different kind of styli can be mounted. It can be converted into a star stylus or any other desirable configuration.

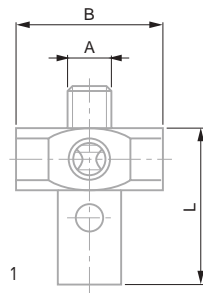

No	=	Rod	Drawing N°	A mm	Ø mm	L mm	B mm	g
03969046	5 way cross shaped stylus M3	Inox	1	M3	-	13	10	3,7

M2 Adaptors

In some cases, accessories that are directly compatible with a probe are not suitable for specific applications. Therefore, it is possible to use an adaptor in order to mount other styli with different threads on it.

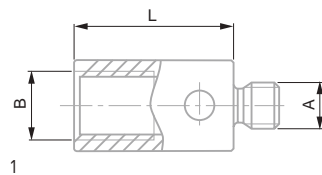

No	=	Rod	Drawing N°	A mm	Ø mm	L mm	B mm	g
03969061	Adapter M2-M3	Inox	1	M2	-	7	M3	0,5





M3 Adaptors

In some cases, accessories that are directly compatible with a probe are not suitable for specific applications. Therefore, it is possible to use an adaptor in order to mount other styli with different threads on it.

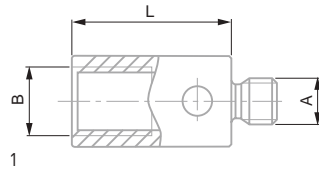

No	=	Rod	Drawing N°	A mm	Ø mm	L mm	B mm	g
03969062	ADAPTER M3-M2	Inox	1	M3	-	5	M2	0,5



Stylus Tightening Keys

Probes and styli are fragile and sensitive items. A special key is provided for fixing a stylus on the probe in order to prevent any damages caused by over-tightening.

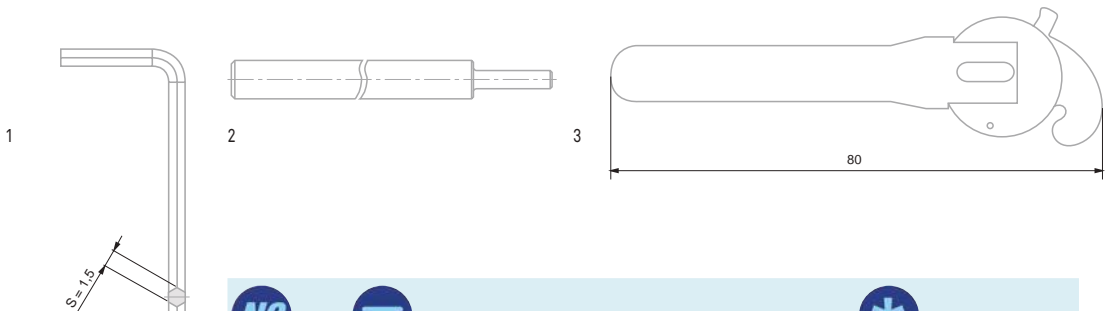

No	=	Drawing N°
042086	Hexagonal key 1,5 mm	1
047866	Stylus key M2 or M3	2
050697	Tightening key for carbon fibre styli	3



Stylus Kit

In order to perform several types of measurement, it is often necessary to keep several models of styli. This is why TESA has created standard kits, comprising styli for a variety of dimensions as well as extensions to suit.



No		Kit N° 1, M2 03969086	Kit N° 2, M2 03969087	Kit N° 3, M2 + rigid probe 03969089	Kit N° 1, M3 03969101	Kit N° 2, M3 + rigid probe 03969040
03969085	Case for accessories	1				
047866	Stylus key M2 or M3	2				
049652	Key	2				
050697	Tightening key for carbon fibre styli	2				
03969231	Extension, inox, M2, L = 10 mm	1	1	1		
03969232	Extension, inox, M2, L = 20 mm	1	1	1		
03969233	Extension, inox, M2, L = 30 mm		1			
03969270	Extension, carbone, M2, L = 40 mm	1				
03969044	Extension, inox, M3, L = 10 mm				1	1
03969045	Extension, inox, M3, L = 20 mm				1	1
03969054	5 way cross shaped stylus, inox, M2	1		1		
03969046	5 way cross shaped stylus, inox, M3				1	1
03969082	5 way cross shaped stylus, inox, M2	1				
03969201	Stylus, inox, ruby ball tip, M2, Ø 1 mm, L = 10 mm		1			
03969202	Stylus, inox, ruby ball tip, M2, Ø 2 mm, L = 10 mm	1	1			
03969203	Stylus, inox, ruby ball tip, M2, Ø 3 mm, L = 10 mm		1			
03969204	Stylus, inox, ruby ball tip, M2, Ø 4 mm, L = 10 mm	1	1			
03969212	Stylus, inox, ruby ball tip, M2, Ø 2 mm, L = 20 mm	2		1		
03969213	Stylus, inox, ruby ball tip, M2, Ø 3 mm, L = 20 mm	2		1		
03969221	Stylus, carbide, ruby ball tip, M2, Ø 1 mm, L = 20 mm	1				
03969260	Stylus, carbone ruby ball tip, M2, Ø 4 mm, L = 50 mm	1				
03969302	Stylus, inox, ruby ball tip, M3, Ø 2 mm, L = 21 mm				1	1
03969303	Stylus, inox, ruby ball tip, M3, Ø 3 mm, L = 21 mm				1	1
03969304	Stylus, inox, ruby ball tip, M3, Ø 4 mm, L = 21 mm				1	1
03969214	Stylus, inox, ruby ball tip, Ø 4 mm, L = 20 mm			1		
03969047	Rigid probe, Ø 6.35 mm			1		1



Basic Fixturing System

The basic clamping kit is perfect for fixing easily any prototype or single parts by using the inserts integrated in the granit measuring table of the TESA measuring machine.



03969010

Basic fixturing kit

Is directly compatible with the inserts of the granit table of the coordinate measuring machine.

Advanced Clamping System

Advanced clamping kit is an easy-to-use system built around the vertical supports to be screwed onto a base-plate. Other specific components are designed to be coupled to the extremity of the columns in order to optimise the flexibility of the device, obtain exactly the required heights and to lock at best the part to be measured.



03969504

Bronze SWIFTFIX Kit

= 03969507 + 03969510

03969505

Silver SWIFTFIX Kit

= 03969508 + 03969510

03969506

Gold SWIFTFIX Kit

= 03969509 + 03969510

03969507

Bronze FIXTURE Kit Case

Includes 46 fixturing elements, without baseplate

03969508

Silver FIXTURE Kit Case

Includes 66 fixturing elements, without baseplate

03969509

Gold FIXTURE Kit Case

Includes 93 fixturing elements, without baseplate

03969510

400 x 400 SWIFTFIX Baseplate

400 x 400 x 12 mm



Additional Software

As it is sometimes necessary to adapt your machine and the measurement process to specific needs, TESA offers additional software that makes the instrument more powerful.



No	=	✳
03969009	REFLEXSCAN 3D	For reverse engineering
04981004	STAT-EXPRESS Machine	To get real-time statistics
04981001	DATA-DIRECT	For the collection and processing of measurement data in real time



Camera Kit

This kit makes it easy to convert any 3D TESA machine into a profile projector! There is no need to own two separate machines to take readings of certain features that are impossible to measure in a tactile way, such as engravings or small parts.



No	=	✳
S39040072	Camera kit No. 1	With screen
S39040070	Camera kit No. 2	Without screen



 No	
03969065	Extension M8, L = 50 mm
03960175	Air saver
03960172	Separator
03969003	Protective cover
H005471	Joystick for MH3D Dual
03969103	Diaclean 1 l
03969047	Rigid probe
82-1631	TESA demo block
03969095	HEXAGON demo block
03969011	Qualification sphere without certificate
03969511	Qualification sphere with certificate
03969001	MH3D table with drawers
03960270	Table for MH3D
S39900072	USB printer



TRADEMARKS REGISTERED IN SWITZERLAND AND/OR OTHER COUNTRIES



TECHNOLOGY



CARY

SWISS



- TESA
- TESA fig.
- ALESOMETRE
- ALESOTEST
- CAPA μ SYSTEM fig.
- CARY
- COMPAC
- COMPAC fig.
- COMPAC GENEVE fig.
- DIAMASTER
- DIGICO
- DIGIT-CAL
- DIGITMASTER
- DURA-CAL
- ETALON
- ETALON fig.
- ETALON SWITZERLAND fig.
- IMICRO
- INOTEST
- INTERAPID
- INTERAPID fig.
- ISOMASTER
- JUNIOR
- JUNIOR fig.
- MAGNA μ SYSTEM fig.
- MERCER
- MESOBOR
- MICRO-HITE
- MICROMASTER
- μ HITE fig.
- POPCAL
- ROCH FRANCE fig.
- ROCTEST
- RUGOSURF fig.
- SHOPCAL
- STANDARD GAGE fig.
- TESA DIGITMASTER
- TESA DUOTAST
- TESA EAGLE fig.
- TESA-HITE
- TESA MEMO-HITE
- TESA MICRO-HITE
- TESA MULTI-GAGE
- TESA-REFLEX
- TESA SWISSCAL
- TESA SWISSTAST
- TESACAL
- TESADIA
- TESADIGIT
- TESAMASTER
- TESA- μ HITE fig.
- TESANORM fig.
- TESASCAN
- TESA-SCOPE
- TESASET
- TESASTAR
- TESASTAR fig.
- TESATAST
- TESATRONIC
- TESATRONIC MULTILINE
- TESA-VISIO
- TRI-O-BOR
- TRIOMATIC
- UNIMASTER
- UNITEST
- UNITEST fig.
- VERIBOR



NUMERICAL INDEX



001					
00110101	C-6	00250505	C-19	00510711	B-14
	29, 30, 31	00269027	C-16	00510721	B-14
00110102	C-6	003		00510722	B-14
00110103	C-6	00310001	C-4, 30, 31	00510741	B-14
00110104	C-6	00310002	C-4	00510751	B-14
00110105	C-6	00310003	C-4	00510801	B-14
00110106	C-6	00310004	C-4	00510821	B-14
00110107	C-6	00310005	C-4	00510822	B-14
00110108	C-6	00310006	C-4	00510841	B-14
00110109	C-6	00310007	C-4	00510861	B-14
00110110	C-6	00310008	C-4	00510871	B-14
00110111	C-6	00310009	C-4	00510911	B-22
00110112	C-6	00310010	C-4	00510915	B-23
00110113	C-6	00311301	C-10	00510921	B-22
00111901	C-23	00312301	C-27	00510922	B-22
00111902	C-23	004		00510941	B-22
00111903	C-23	00440001	C-17	00510942	B-22
00111904	C-23	00440002	C-17	00512015	B-23
00111905	C-23	00440003	C-17	00512016	B-23
00119046	C-7	00440004	C-17	00512017	B-23
00119047	C-7	00440005	C-17	0051610365	B-8
00119048	C-7	00440006	C-17	00520001	B-7
00119049	C-7	00440007	C-17	00520002	B-6
00119050	C-7	005		00530020	C-30
00140101	C-23	00510004	B-7	00530021	C-30
00140301	C-22	00510008	B-6, 30	00530094	B-4
00160101	E-7	00510033	C-29		C-31, 33
00160201	C-25	00510041	B-9, C-29	00530095	B-4
002		00510045	B-6	00530096	B-4
00210001	C-18	00510046	B-6	00530097	B-4
00210002	C-18	00510047	B-9	00530103	B-9
00210003	C-18	00510050	B-6	00530104	B-9
00210004	C-18	00510111	B-17	00530105	B-9
00210101	C-11	00510112	B-9	00530110	B-9
00210102	C-11	00510123	B-17	00530111	B-9
00210201	C-15	00510124	B-17	00530112	B-9
00210202	C-15	00510125	B-17	00530120	B-9
00210203	C-15	00510126	B-17	00530121	B-9
00210204	C-15	00510133	B-17	00530130	B-9
00210205	C-15	00510134	B-17	00530131	B-9
00210206	C-15	00510134	B-17	00530319	B-3, C-32
00210301	C-14	00510144	B-17	00530320	B-3, C-32
00211002	C-26	00510143	B-17	00530321	B-3, C-33
00211003	C-26	00510144	B-17	00530322	B-3
00211004	C-26	00510163	B-17	00530323	B-3
00211005	C-26	00510164	B-17	00530324	B-10
00211201	C-28	00510173	B-17	00530325	B-10
00219066	C-21	00510175	B-18	00530326	B-10
00240015	C-19	00510177	B-18	00530327	B-10
00240501	C-19	00510179	B-18	00530328	B-10
00240502	C-19	00510181	B-18	00530329	B-10
00240503	C-19	00510201	B-18	00530330	B-10
00240504	C-19	00510202	B-18	00530331	B-10
00240505	C-19	00510211	B-18	00530332	B-10
00240601	C-19	00510212	B-18	00530333	B-10
00240602	C-19	00510222	B-18	00530334	B-10
00240603	C-19	00510371	B-23	00530335	B-10
00240700	C-20	00510375	B-23	00530336	B-10
00240701	C-20	00510383	B-23	00530337	B-10
00240702	C-20	00510385	B-23	00530338	B-10
00240703	C-20	00510387	B-23	00530339	B-10
00240704	C-20	00510393	B-23	00530340	B-10
00240705	C-20	00510506	B-13	00530341	B-10
00240706	C-20	00510509	B-13	00530342	B-10
00240707	C-20	00510511	B-13	00530343	B-10
00240708	C-20	00510512	B-13	00530344	B-10
00240709	C-20	00510521	B-13	00530345	B-10
00240710	C-20	00510522	B-13	00530346	B-10
00240711	C-20	00510523	B-13	00530347	B-10
00240712	C-20	00510531	B-13	00530348	B-10
00240713	C-20	00510533	B-13	00530349	B-10
00240714	C-20	00510541	B-13	00530350	B-10
00240715	C-20	00510542	B-13	00530351	B-10
00250015	C-19	00510551	B-13	00530352	B-10
00250115	C-19	00510601	B-13	00530353	B-10
00250501	C-19	00510611	B-13	00530354	B-10
00250502	C-19	00510611	B-13	00530355	B-10
00250503	C-19	00510621	B-13	00530356	B-10
00250504	C-19	00510641	B-13	00530357	B-10
		00510651	B-13	00530358	B-10
		00510661	B-13	00530359	B-10
		00510671	B-13	00530360	B-10
		00510681	B-13	00530361	B-10
		00510691	B-13	00530362	B-10
		00510701	B-14	00530363	B-10
				00530364	B-10
				00530365	B-10
				00530366	B-10
				00530367	B-10
				00530368	B-10
				00530369	B-10
				00530370	B-10
				00530371	B-10
				00530372	B-10
				00530373	B-10
				00530374	B-10
				00530375	B-10
				00530376	B-10
				00530377	B-10
				00530378	B-10
				00530379	B-10
				00530380	B-10
				00530381	B-10
				00530382	B-10
				00530383	B-10
				00530384	B-10
				00530385	B-10
				00530386	B-10
				00530387	B-10
				00530388	B-10
				00530389	B-10
				00530390	B-10
				00530391	B-10
				00530392	B-10
				00530393	B-10
				00530394	B-10
				00530395	B-10
				00530396	B-10
				00530397	B-10
				00530398	B-10
				00530399	B-10
				00530400	B-10
				00530401	B-10
				00530402	B-10
				00530403	B-10
				00530404	B-10
				00530405	B-10
				00530406	B-10
				00530407	B-10
				00530408	B-10
				00530409	B-10
				00530410	B-10
				00530411	B-10
				00530412	B-10
				00530413	B-10
				00530414	B-10
				00530415	B-10
				00530416	B-10
				00530417	B-10
				00530418	B-10
				00530419	B-10
				00530420	B-10
				00530421	B-10
				00530422	B-10
				00530423	B-10
				00530424	B-10
				00530425	B-10
				00530426	B-10
				00530427	B-10
				00530428	B-10
				00530429	B-10
				00530430	B-10
				00530431	B-10
				00530432	B-10
				00530433	B-10
				00530434	B-10
				00530435	B-10
				00530436	B-10
				00530437	B-10
				00530438	B-10
				00530439	B-10
				00530440	B-10
				00530441	B-10
				00530442	B-10
				00530443	B-10
				00530444	B-10
				00530445	B-10
				00530446	B-10
				00530447	B-10
				00530448	B-10
				00530449	B-10
				00530450	B-10
				00530451	B-10
				00530452	B-10
				00530453	B-10
				00530454	B-10
				00530455	B-10
				00530456	B-10
				00530457	B-10
				00530458	B-10
				00530459	B-10
				00530460	B-10
				00530461	B-10
				00530462	B-10
				00530463	B-10
				00530464	B-10
				00530465	B-10
				00530466	B-10
				00530467	B-10
				00530468	B-10
				00530469	B-10
				00530470	B-10
				00530471	B-10
				00530472	B-10
				00530473	B-10
				00530474	B-10
				00530475	B-10
				00530476	B-10
				00530477	B-10
				00530478	B-10



03939219	Q-9	03969282	Q-11	04981004	A-4	05969011	L-13	06130110	D-5	06830401	P-15
03939240	Q-4	03969283	Q-11		Q-20	05969012	L-13	06130111	D-5	06830428	P-15
03939241	Q-4	03969284	Q-11			05969020	L-12	06130112	D-5	06830601	P-16
03939242	Q-4	03969286	Q-11	050		05969021	L-12	06130113	D-5	06830602	P-16
03939243	Q-4	03969292	Q-14	05030010	O-55	05969022	L-12	06130114	D-5	06860001	P-22, 25
03939267	Q-5	03969293	Q-11	05030012	A-8	05969023	L-12	06130115	D-5	06860002	P-22, 25
03939268	Q-5	03969294	Q-11		O-56	05969024	L-12	06130116	D-5	06860003	P-22, 25
03939269	Q-5	03969295	Q-11	050697	Q-17, 18	05969032	L-12	06130117	D-5	06860004	P-22, 25
03939350	Q-10	03969301	Q-12			05969033	L-12	06130118	D-5	06860005	P-22, 25
03960172	Q-21	03969302	Q-12, 18	053		05969034	L-12	06130119	D-5	06860006	P-22, 25
03960175	Q-21	03969303	Q-12, 18	05330003	J-5	05969007	L-12	06130120	D-5	06860015	P-22
03960270	Q-21	03969304	Q-12, 18	05330004	J-5	05969008	L-12	06130121	D-5	06860016	P-22
03969001	Q-21	03969305	Q-12	05330005	J-5			06130122	D-5	06860017	P-22
03969003	Q-21	03969310	Q-12	05330202	J-4			06130123	D-5	06860018	P-25
03969007	A-10	03969312	Q-12	05330203	J-3	060		06130124	D-5	06860020	P-22, 25
03969009	Q-20	03969320	Q-15	05331000	J-9	06030010	C-3	06130125	D-5	06860021	P-22, 25
03969010	Q-19	03969324	Q-12	05331002	J-9		C-32, 33	06130126	D-5	06860022	P-22
03969011	Q-21	03969326	Q-12	05331050	J-8	06030020	C-3, 32	06130127	D-5	06860022	P-22
03969044	Q-15, 18	03969330	Q-13	05331054	J-8	06030021	C-3	06130128	D-5	06860024	P-22, 25
03969045	Q-15, 18	03969332	Q-12	05331058	J-8	06030022	C-3	06160002	D-8	06860025	P-22, 25
03969046	Q-16, 18	03969343	Q-12	05331061	J-8	06030023	C-3	06160003	D-8	06860026	P-25
03969047	Q-18, 21	03969353	Q-12	05331063	J-8	06030029	C-3	06160005	D-8	06860027	P-22
03969054	Q-16, 18	03969504	Q-19	05331201	J-8	06030030	C-3, 33	06160006	D-8	06860029	P-22
03969055	Q-14	03969505	Q-19	05331202	J-8	06030031	C-3	06160006	D-8	06860030	P-17
03969056	Q-14	03969506	Q-19	05331204	J-8	06030032	C-3	06160007	D-8	06860031	P-17
03969057	Q-14	03969507	Q-19	05331206	J-8	06030033	C-3	06230023	D-11	06860032	P-17
03969058	Q-14	03969508	Q-19	05331210	J-8	06030034	C-10	06230024	D-11	06860033	P-17
03969061	Q-16	03969509	Q-19	05331450	J-9	06030035	C-10	06230025	D-11	06860046	P-19
03969062	Q-17	03969510	Q-19	05331500	J-7	06030038	C-27	06230026	D-11	06860056	P-25
03969065	Q-21	03969511	Q-21	05331502	J-7	06030039	C-27	06230027	D-11	06860057	P-25
03969081	Q-14			05331550	J-7	06030040	C-27	06230028	D-11	06860058	P-25
03969082	Q-14, 18	042		05331551	J-7	06030041	C-15	06230029	D-11	06860059	P-25
03969083	Q-14	042086	Q-17	05331750	J-10	06030042	C-15	06230030	D-11	06860060	P-22
03969084	Q-14			05360004	J-11	06030043	C-15	06230031	D-11	06860061	P-22
03969085	Q-18	044		05360006	J-11	06030044	C-15	06230032	D-11	06860145	P-18
03969095	Q-21	04430003	O-53	05360014	J-11	06030045	C-16	06230033	D-11	06860186	P-18
03969103	Q-21	04430008	O-47			06030047	C-22	06230034	D-11	06860187	P-19
03969201	Q-11, 18	04430009	O-49	056		06030048	C-22	06230035	D-11	06860287	P-17
03969202	Q-11, 18	04430010	O-49	056109	A-12	06030049	C-22	06230036	D-11	06860288	P-17
03969203	Q-11, 18	04430011	O-51	056133	M-21	06030050	C-22	06230037	D-11	06860289	P-17
03969204	Q-11, 18	04430012	L-7	056223	M-21	06030051	C-22	06230038	D-11	06860290	P-17
03969205	Q-11			056224	M-22	06030062	C-18	06230039	D-11	06860400	P-18
03969206	Q-11	04460004	O-54	056631	M-22	06030063	C-18	06230051	D-11	06860401	P-18
03969208	Q-11	04460007	O-54	056633	M-22	06030064	C-18	06230052	D-11	06869055	P-22
03969210	Q-14			056639	M-22	06030065	C-18			06869056	P-22
03969212	Q-11, 18	047		056641	M-22	06030066	C-18	064		06869057	P-22
03969213	Q-11, 18	04760087	L-7			06030067	C-18	06430000	A-6	06869101	P-28
03969214	Q-11, 18	04760099	A-12	057		06030069	C-26			06869102	P-28
03969218	Q-13	04760180	A-7	05710012	H-6	06030070	C-26	065		06869106	P-28
03969220	Q-11	04760181	A-10	05710013	H-6	06030071	C-3	065151011	K-6	06869107	P-28
03969221	Q-11, 18	04760182	A-10	05710014	H-6	06030072	C-3	065151012	K-6	06869108	P-28
03969222	Q-11	04761017	A-11	05710015	H-6	06030073	C-3	065151014	K-5	06869109	P-28
03969223	Q-11	04761023	A-10	05710016	H-6	06030074	C-3	065151021	K-5	06869110	P-28
03969224	Q-11	04761024	A-10	05710017	H-6	06030075	C-3	065151027	K-5	06869111	P-28
03969225	Q-11	04761027	A-9	05710018	H-6	06030076	C-3	0651512011	K-6	06869112	P-28
03969226	Q-11	04761037	A-11	05710018	H-6	06030077	C-3	0651512012	K-6	06869113	P-28
03969230	Q-15	04761038	A-10	05710090	H-5	06030078	C-3	0651512014	K-5	06869118	P-28
03969231	Q-15, 18	04761046	A-9	05710091	H-5	06030079	C-12	0651512021	K-5	06869119	P-28
03969232	Q-15, 18	04761049	A-9	05710092	H-5	06030080	C-12	0651512028	K-5	06869120	P-28
03969233	Q-15, 18			05710093	H-5	06030081	C-12	0651515011	K-6	06869121	P-28
03969234	Q-15	04761052	A-9	05740001	H-7	06030082	C-12	0651515012	K-6	06869122	P-28
03969238	Q-15	04761054	A-11	05760013	H-7	06030083	C-12	0651515014	K-5		
03969239	Q-15			05760027	H-7	06030084	C-12	0651515021	K-5	069	
03969240	Q-15	04761055	A-11	05760029	H-7	06030085	C-14	0651515027	K-5	06930011	M-8
03969246	Q-15			057655	M-22	06030087	C-17	0651516011	K-6	06930012	M-11
03969247	Q-15					06030088	C-17	0651516012	K-6	06930013	M-5
03969251	Q-14	04761056	A-11	058		06030089	C-17	0651516014	K-5	06960033	M-20
03969252	Q-14			058213	A-12	06030090	C-17	0651516021	K-5	06960034	M-14
03969253	Q-14	04761057	A-11			06030091	C-17	0651516027	K-5	06960035	M-23
03969259	Q-11	04761059	J-11	059		06030092	C-17	0652500422	K-7	06960036	M-17
03969260	Q-11, 18	04761060	A-10	05930000	L-7	06030093	C-17			06960037	M-18
03969261	Q-11	04761062	A-9	05930003	L-7	06030094	C-17	067		06960038	M-18
03969262	Q-11	04761063	A-9	05930004	L-5	06030095	C-17	06719000	J-16	06960039	M-18
03969263	Q-11	04761070	L-7	05930008	L-5	06030096	C-17	06739001	J-13	06960040	M-18
03969267	Q-11	04761071	A-5	05930011	L-9	06030097	C-17	06769002	K-8	06960041	M-24
03969268	Q-11	04768000	A-11	05930013	L-7	06030099	C-17	06769004	I-24	06960042	M-22
03969269	Q-11			05930015	L-7	06060021	C-26	06769005	J-16	06960043	M-21
03969270	Q-15, 18	04768001	A-11	05939001	L-11			06769006	I-23	06960044	M-21
03969271	Q-11	04768002	J-11	05960025	L-8	06130101	D-5	06769007	I-24	06960045	M-22
03969272	Q-11			05960030	L-7	06130102	D-5		P-22, 25	06960046	M-22
03969276	Q-11	047866	Q-17, 18	05960039	L-7	06130103	D-5	06769009	K-8	06960048	M-15
03969277	Q-15			05969000	L-12	06130104	D-5	06769010	I-25	06960049	M-17
03969278	Q-15	049		05969001	L-12	06130105	D-5			06960050	M-19
03969279	Q-15	049652	Q-18	05969002	L-13	06130106	D-5	068		06960051	M-19
03969280	Q-15	04981001	A-3	05969004	L-13	06130107	D-5	06830031	P-26	06960052	M-19
03969281	Q-15			05969009	L-13	06130108	D-5	06830034	P-26	06960053	M-19
		04981002	A-4	05969010	L-13	06130109	D-5	06830035	P-26	06960054	M-19





06960055 M-23	075115821 B-7	0951753002 I-26	CJ1B4A K-14	CJ1L1S0 K-9	S47010025 A-9
06960056 M-18, 19	076	0951753003 I-26	CJ1B4C K-14	CJ1L1S2 K-9	S47078588 A-10
06960057 M-18	076115566 J-15	0951753013 I-26	CJ1B4IA K-14	CJ1L2E0 K-9	S47120002 A-5, 9
06960058 M-19	076115567 J-15	0951753014 I-26	CJ1B4IM K-14	CJ1L2E2 K-9	S47120003 A-5
06960059 M-22	077	0951753015 I-26	CJ1B5A K-14	CJ1L2S0 K-9	S48001721 O-57
06960061 M-19	07739001 N-31	0951753045 I-26	CJ1B5C K-14	CJ1L2S2 K-9	S48001722 O-57
06960062 A-12	07739002 N-31	0951753046 I-26	CJ1B5IA K-14	CJ1L5E0 K-10	S48001723 O-57
06960064 M-24	07739003 N-31	0951754511 I-27	CJ1B5IM K-14	CJ1L5E2 K-10	S48001724 O-57
06960065 M-24	07769001 N-31	82	CJ1BAA K-16	CJ1L5S0 K-10	S48001725 O-57
06960066 M-24	07769003 N-31	82-1631 Q-21	CJ1BBA K-16	CJ1L5S2 K-10	S48001731 O-57
06960067 M-19	07769004 N-31	200	CJ1BBA1 K-15	CJ1L10E0 K-10	S53070174 A-10
06960081 M-18	07769003 N-31	212GL G-11	CJ1BBA2 K-15	CJ1L10E2 K-10	S53300165 A-10
06960100 M-13	07769005 N-31	212L G-11	CJ1BBA3 K-15	CJ1L10S0 K-10	S59110152 L-8
06960101 M-16	07769006 N-31	213 G-11	CJ1BBA4 K-15	CJ1L10S2 K-10	S59110489 L-8
06960102 M-17	078	213G G-11	CJ1BBA5 K-15	CJ1LL1E0 K-10	S59300103 L-9
06960103 M-24	078110733 D-13	215 G-11	CJ1BBA6 K-15	CJ1LL1S0 K-10	S59300104 L-9
071	078110735 D-13	215GL G-11	CJ1BBA7 K-15	CJ1LL2E0 K-10	S59300107 L-9
071115887 C-5	078110737 D-13	216 G-11	CJ1BBA8 K-15	CJ1LL2S0 K-10	T
071115888 C-5	078110739 D-13	215G G-11	CJ1BBA9 K-15	CJ1MTXK K-13, 16	TL01-0002 P-9
071115889 C-5	078112356 D-13	215GL G-11	CJ1BBM1 K-15	CJ1N1E K-13	TL01-0003 P-9
071115890 C-5	078112357 D-13	216G G-11	CJ1BBM2 K-15	CJ1N1S K-13	TL01-0004 P-9
071115891 C-5	078112358 D-13	222GL G-11	CJ1BBM3 K-15	CJ1N2E K-13	TL01-0005 P-9
071115892 C-5	078112359 D-13	222L G-11	CJ1BBM4 K-15	CJ1N2S K-13	TL01-0006 P-9
071115893 C-5	078112360 D-13	223 G-11	CJ1BBM5 K-15	CJ1N3 K-13, 16	TL01-0007 P-9
071115894 C-5	078112361 D-13	223G G-11	CJ1BBM6 K-15	CJ1N3E K-13	TL01-0008 P-9
071115940 C-13	078112362 D-13	225 G-11	CJ1BBM7 K-15	CJ1N3S K-13	TL01-0009 P-9
072	078112363 D-13	225G G-11	CJ1BBM8 K-15	CJ1N4E K-13	TL01-0010 P-9
072103522 C-13	078112364 D-13	232GL G-12	CJ1BBM9 K-15	CJ1N4S K-13	TL01-0011 P-9
072108669 C-8	078112365 D-13	232L G-12	CJ1BOA1 K-15	CJ1N50 K-13, 16	TL01-0012 P-9
072108691 C-8	078112366 D-13	233 G-12	CJ1BOA2 K-15	CJ1NGC K-13, 16	TL01-0013 P-9
072108722 C-8	078112367 D-13	233G G-12	CJ1BOA3 K-15	CJ1NLSM K-13, 16	TL01-0015 P-10
072110123 C-25	078112368 D-13	235G G-12	CJ1BOA4 K-15	CJ1PTXK K-13, 16	TL01-0016 P-10
072110816 C-9	078112369 D-13	242 G-12	CJ1BOA5 K-15	CJ1X1E0 K-11	TL01-0017 P-10
072110853 C-9	078112370 D-13	242G G-12	CJ1BOA6 K-15	CJ1X1E2 K-11	TL01-0018 P-10
072110978 C-8	078112371 D-13	243L G-12	CJ1BOA7 K-15	CJ1X1E0 K-11	TL01-0019 P-10
072112020 C-24	078112372 D-13	243L G-12	CJ1BOA8 K-15	CJ1X1S0 K-11	TL01-0020 P-10
072112021 C-24	078112373 D-13	245 G-12	CJ1BOA9 K-15	CJ1X1S2 K-11	TL01-0021 P-10
072115943 C-28	079	245G G-12	CJ1BOM1 K-15	CJ1X1S10 K-11	TL01-0022 P-10
072116406 C-5	079105694 H-8	300	CJ1BOM2 K-15	CJ1X2E0 K-11	TL01-0026 P-10
072116407 C-5	079105704 H-8	353 F-11	CJ1BOM3 K-15	CJ1X2E10 K-11	TL01-0027 P-10
072116408 C-5	079105756 H-8	353E F-11	CJ1BOM4 K-15	CJ1X2S0 K-11	TL01-0038 P-11
072116409 C-5	079111401 H-8	355 F-15	CJ1BOM5 K-15	CJ1X2S2 K-11	TL01-0039 P-11
072116410 C-11	079112051 H-8	355E F-15	CJ1BOM6 K-15	CJ1X2S10 K-11	TL01-0040 P-11
074	079112052 H-8	365S F-15	CJ1BOM7 K-15	CJ1X3E0 K-11	TL02-0001 P-11
074105993 G-9	081	367 F-17	CJ1BOM8 K-15	CJ1X3E10 K-11	TL02-0002 P-11
074105994 G-9	081112053 M-25	367E F-17	CJ1C1E0 K-12	CJ1X3S0 K-11	TL02-0003 P-11
074105995 G-9	081112054 M-25	500	CJ1C1E10 K-12	CJ1X3S10 K-11	TL02-0016 P-11
074106026 G-8, 9	081112055 M-25	512K F-12	CJ1C1S0 K-12	CJ1XDL K-13, 16	TL02-0017 P-11
074106331 G-8, 9	081112056 M-25	532 F-12	CJ1C1S10 K-12	CJ1XX1E0 K-11	TL02-0018 P-11
074106358 G-9	081112057 M-25	532E F-12	CJ1C2E0 K-12	CJ1XX1S0 K-11	TL02-0019 P-11
074106360 G-9	081112058 M-25	533S F-12	CJ1C2E10 K-12	CJ1XX2E0 K-11	TL02-0021 P-11
074107893 G-9	081112059 M-25	555 F-16	CJ1C2S0 K-12	CJ1XX2S0 K-11	TTA 20 O-53
074107895 G-9	081112060 M-25	555E F-16	CJ1C2S10 K-12	CJ1XX3E0 K-11	Z
074107897 G-9	081112061 M-25	556 F-18	CJ1C3E0 K-12	CJ1XX3S0 K-11	Z173-0908 P-11
074108603 G-9	081112062 M-25	556E F-18	CJ1C3E10 K-12	CJ1XX450 K-11	Z173-0920 P-11
074108942 G-8	081112063 M-25	556G F-19	CJ1C3S0 K-12	CJ128021010A K-16	Z173-0921 P-11
074110481 G-9	081112064 M-25	565S F-16	CJ1C3S10 K-12	CJ128021011A K-16	Z173-0922 P-11
074110482 G-9	081112344 M-25	567 F-18	CJ1CB18 K-16	CJ128021012A K-16	Z173-0923 P-11
074110491 G-9	081112345 M-25	700	CJ1CB24 K-16	CJ128021013A K-16	Z173-0961 P-12
074110492 G-9	081112346 M-25	712 F-13	CJ1CB40 K-16	CP 352S F-24	Z173-2020 P-12
074110493 G-9	095	722 F-13	CJ1CC1E0 K-12	CP 353 F-24	Z173-2024 P-12
074110507 G-9	0951750002 J-12	732 F-13	CJ1CC1S0 K-12	CP 355 F-24	Z173-2025 P-12
074111366 G-8	0951750003 J-12	900	CJ1CC2E0 K-12	S	Z178-0607 P-12
074111367 G-8	0951750005 J-12	96160013 O-40	CJ1CC2S0 K-12	S18001695 G-4	Z178-0610 P-12
074111368 G-8	0951750006 J-12	96410012 O-39	CJ1CC3E0 K-12	S39040070 Q-20	Z178-0940 P-12
074111369 G-8	0951750007 J-12	96430029 O-41	CJ1CC3S0 K-12	S39040072 Q-20	Z178-0942 P-12
074111375 G-8	0951750181 I-25	96441041 O-41	CJ1CEB3 K-16	S39900072 Q-21	Z178-2009 P-12
074111376 G-8	0951750182 I-25	C	CJ1CEB4 K-16	S41077249 O-59	Z178-2020 P-12
074111474 G-8	0951750184 I-25	CJ1B1C K-14	CJ1D1E0 K-9	S41078077 O-59	Z178-2025 P-12
074111502 G-8	0951750187 I-25	CJ1B1IM K-14	CJ1D1E2 K-9	S41078079 O-59	Z178-2026 P-12
074111503 G-8	0951750222 E-8	CJ1B2A K-14	CJ1D1S0 K-9	S41078087 O-59	Z178-3028 P-12
074111504 G-8	0951750223 E-8	CJ1B2C K-14	CJ1D1S2 K-9	S41078228 O-59	
074111505 G-8	0951750224 E-8	CJ1B2IA K-14	CJ1D2E0 K-9	S41078230 O-59	
074115604 H-9	0951750225 E-8	CJ1B2IM K-14	CJ1D2E2 K-9	S41078332 O-59	
074115605 H-9	0951751533 J-13	CJ1B3A K-14	CJ1D2S0 K-9	S41078332 O-59	
074115606 H-9	0951751534 J-13	CJ1B3B K-14	CJ1D2S2 K-9	S41078654 O-59	
074115607 H-9	0951751535 J-13	CJ1B3C K-14	CJ1EB12 K-16	S41078751 O-59	
074115608 H-9	0951751605 J-12	CJ1B3A K-14	CJ1ED25N K-13, 16	S41078752 O-59	
074115664 H-9	0951751607 J-12	CJ1B3B K-14	CJ1EL25N K-13, 16	S47001891 A-11	
	0951753001 I-26	CJ1B3C K-14	CJ1GTXX K-13, 16	S47010022 A-9	
		CJ1B3IA K-14	CJ1L1E0 K-9	S47010024 A-9	
		CJ1B3IM K-14	CJ1L1E2 K-9		

LEXICON OF PICTOGRAMS

 TESA Design SWISS MADE	 Height of signs/digits	 Diameter	 Maximum relative humidity
 TESA Design – Product from the European Community	 Analogue/numerical indication	 Thread pitch	 Degree of protection
 TESA Design – Product produced outside Europe	 Material measure Measuring system	 Material hardness	 Electromagnetic compatibility
 Product from the European Community	 Capacitive measuring system "CAPA μ SYSTEM", patented	 Measuring force	 Mass
 Product produced outside Europe	 Magnetic measuring system "MAGNA μ SYSTEM", patented	 Shockproof design	 Included in scope of supply
 Order number	 Units of measurement	 Maximum displacement speed	 Packaging
 Standard	 Mm/in conversion	 Product designation	 Identification number
 Measuring range Measuring span	 Maximum permissible errors Limit deviations	 Execution	 Declaration of conformity
 Range of indication Max. plunger travel	 Deviation span of indication	 Special features	 Inspection report
 Displacement range	 Repeatability limit	 Notes	 Inspection report with a declaration of conformity
 Application range	 Hysteresis	 Function mode	 SCS calibration certificate
 Analogue indication Longitudinal scale	 Maximum permissible straightness error	 Floating zero	 Certificate of another type
 Upper vernier	 Maximum permissible flatness error	 Blocking of display	 Page
 Lower vernier	 Maximum permissible roundness error	 Locking of display	 Centred lug back
 Circular scale	 Maximum permissible parallelism error	 Digital interface	 Centred revolution counter
 Dial	 Maximum permissible cylindricity error	 Analogue interface	 Reverse numbering or +left
 mm or in/revolution	 Maximum permissible perpendicularity error	 Control functions	 Dial locking knob
 Number of scale divisions	 Maximum permissible runout error	 Power supply	 Connectivity
 Scale spacing	 Quality grade	 Autonomy	 TWIN
 Scale interval	 Uncertainty of measurement accuracy	 Coefficient of linear expansion	 ABS
 Resolution magnification	 Frame	 Working temperature range	 Height of signs/digits 11 mm
 Numerical scale	 Measuring face or faces	 Operating temperature range	 TESA
 Numerical interval	 Dimensions	 Storage temperature range	 HEXAGON



2014
2015



BEYOND MEASUREMENT

The alliance between SWISS MADE and INNOVATION

www.tesagroup.com