

# S200

## TYPE



**T**ype S200 is a non bearing supported sprag type freewheel. The sprags run directly on the shaft provided by the user. Bearings are required to support axial and radial loads. Lubrication and sealing must also be provided by the installation.

A typical arrangement is to install this type alongside a bearing as shown on the following page. The housing bore to receive the outer race will be machined with a H7 tolerance. A key will transmit the torque. The shaft on which the sprags run must have a surface hardness of

HRc 60 to 62 for a finished depth of 0,6 mm minimum. Core hardness should be HRc 35 to 45. Surface roughness must not exceed 22 CLA. Maximum shaft taper 0,01 mm per 50 mm length. Concentricity between shaft and housing bore should be maintained within TIR 0,05 mm.

The preferred lubrication is oil. The Stieber design allows the use of most of the common lubricants used in power transmission including gear oils with EP additives. When necessary grease lubrication is also possible.

## S200

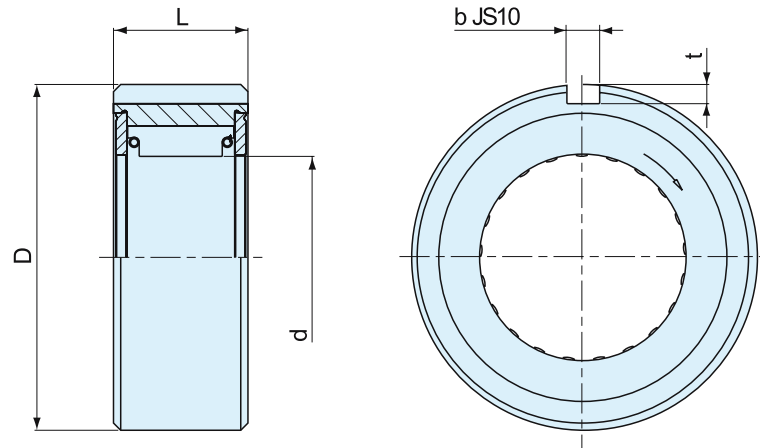

Type	Size	d <sup>+</sup> <sub>-0.025</sub> [mm]	T <sub>KN</sub> <sup>1)</sup> [Nm]	Overrunning speeds		D [mm]	L [mm]	b [mm]	t [mm]	Bearing series	Drag torque T <sub>r</sub> [Ncm]	Weight [kg]
				n <sub>max</sub> <sup>2)</sup> [min <sup>-1</sup> ]	n <sub>amax</sub> <sup>3)</sup> [min <sup>-1</sup> ]							
S200	203	16.510	45	2400	500	40 <sub>-0.016 -0.039</sub>	25	4	2.5	6203	0.01	0.25
	204	18.796	60	2400	500	47 <sub>-0.014 -0.039</sub>	25	5	3	6204	0.01	0.35
	205	23.622	100	1800	400	52 <sub>-0.017 -0.042</sub>	25	5	3	6205	0.02	0.45
	206	32.766	240	1800	350	62 <sub>-0.017 -0.042</sub>	28	7	4	6206	0.02	0.70
	207	42.088	380	1800	300	72 <sub>-0.017 -0.042</sub>	28	7	4	6207	0.02	0.80
	208	46.761	560	1800	200	80 <sub>-0.017 -0.042</sub>	32	10	4.5	6208	0.02	0.90
	209	46.761	560	1800	200	85 <sub>-0.020 -0.042</sub>	32	10	4.5	6209	0.02	0.95
	210	56.09	850	1200	200	90 <sub>-0.020 -0.042</sub>	32	10	4.5	6210	0.03	1.00

## NOTES

- 1)  $T_{max} = 2 \times T_{KN}$   
» Refer to Selection page 10 to 13
  - 2) Inner race overruns
  - 3) Outer race overruns
- » Refer to mounting and maintenance instructions page 16 to 19

## MOUNTING EXAMPLE

